

**aerosmith**<sup>®</sup>  
fastening systems

# FASTENING SYSTEMS

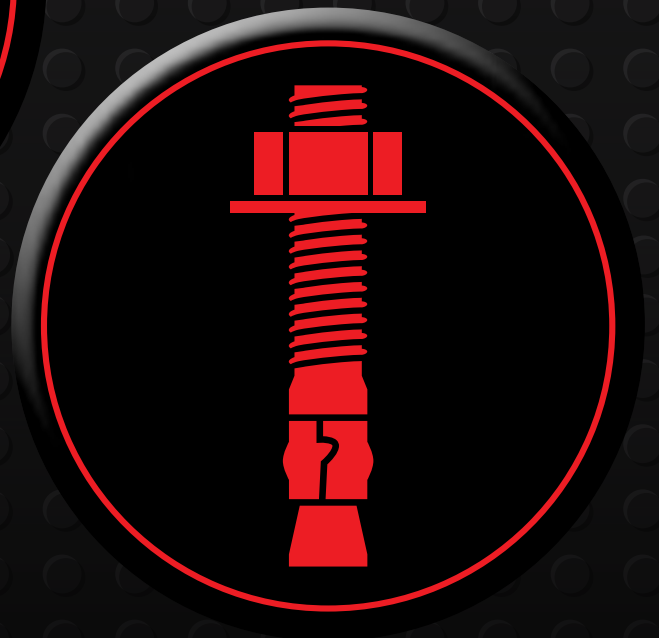

**BUYERS GUIDE**

# aerosmith®

fastening systems

## FASTENING IN CONSTRUCTION

Broadest selection of fasteners to attach materials to Light Gauge Steel, Structural Steel, Concrete and CMU.



## SUPERIOR PERFORMANCE

Performance you can trust for a variety of construction applications



## RELIABLE

World class tools and fasteners to get the job done right and confidently



## FAST AND EASY

Collated fasteners and tools mean less reloading and, often, single hand operation.



## SAVE TIME

Up to 10 times faster than screws, saving you time and money.



# INDEX

## Tools & Pins

ST4200 Fastening Tool . . . . .	8
VersaPin® Fasteners for Steel . . . . .	9
SuperSharp® Pins . . . . .	11
ST2575 & ST1850C4 Trim Fastening Tools . . . . .	12
Trim Pins . . . . .	13
HN25C High Pressure Concrete and Steel Pinner . . . . .	14
HN120 High Pressure Concrete and Steel Pinner . . . . .	15
PowerPin® Fasteners . . . . .	16
PowerPin® Fastener Offerings . . . . .	17
ST3800 High Pressure Single Shot Pinner . . . . .	18
Hex Head® Fasteners . . . . .	19
CT90 High-Speed Pneumatic Fastening . . . . .	20
SurePin® Fasteners . . . . .	21
GT38LI & GT60LI - EXIFTM . . . . .	22
AT150 100 PSI Pneumatic Insulation Tool . . . . .	22
InsulPin™ Fasteners . . . . .	23
GT38LI & GT60LI Gas Power Tools . . . . .	24
TraxPin® Fasteners for Track & Heavy Steel . . . . .	28

## Specialty Pins

PT2000™ 2000 Hour Fasteners . . . . .	27
---------------------------------------	----

## Accessories

Magnetic Adapters & Washers . . . . .	29
Tool Adapters & Washers . . . . .	30
Hoses, Fittings & Service Kits . . . . .	31
Compressors . . . . .	32
Fuel Cells & Battery Packs . . . . .	34

## Mechanical Anchors

Mechanical Anchoring . . . . .	35-65
--------------------------------	-------

## Adhesive Anchoring

Adhesive Anchoring . . . . .	66-72
------------------------------	-------

To review our Terms & Conditions and our Warranty Policies please go to [www.aerosmithfastening.com](http://www.aerosmithfastening.com)

# aerosmith®

fastening systems



*Proudly assembled in our  
state of the art Indianapolis, IN facility*



## The Aerosmith<sup>®</sup> Mission Statement

To provide the highest levels of quality and innovative fastening solutions to the construction and manufacturing industries, while adding value to our clients through Integrity, Service, Performance, and Education. Our Experience, Dedication, and Commitment to Excellence being at the forefront of everything we do.

Established in 1967, Aerosmith<sup>®</sup> Fastening Systems continues to be a leader in developing hardened steel pins and specialty tools for today's unique application challenges, including plywood, Hardie , track to steel, and concrete applications. Our experience and expertise has led us to develop several patented and patent pending products, while specifically redesigning or resourcing tools for fastening materials to steel assemblies and for construction projects.

Construction, Industrial/OEM, and Specialty users benefit from Aerosmith<sup>®</sup> systems by saving time, money, and manpower. Headquartered in Indianapolis, Indiana, Aerosmith<sup>®</sup> is positioned to serve both the United States and a Worldwide Market.



# DIRECT FASTENING

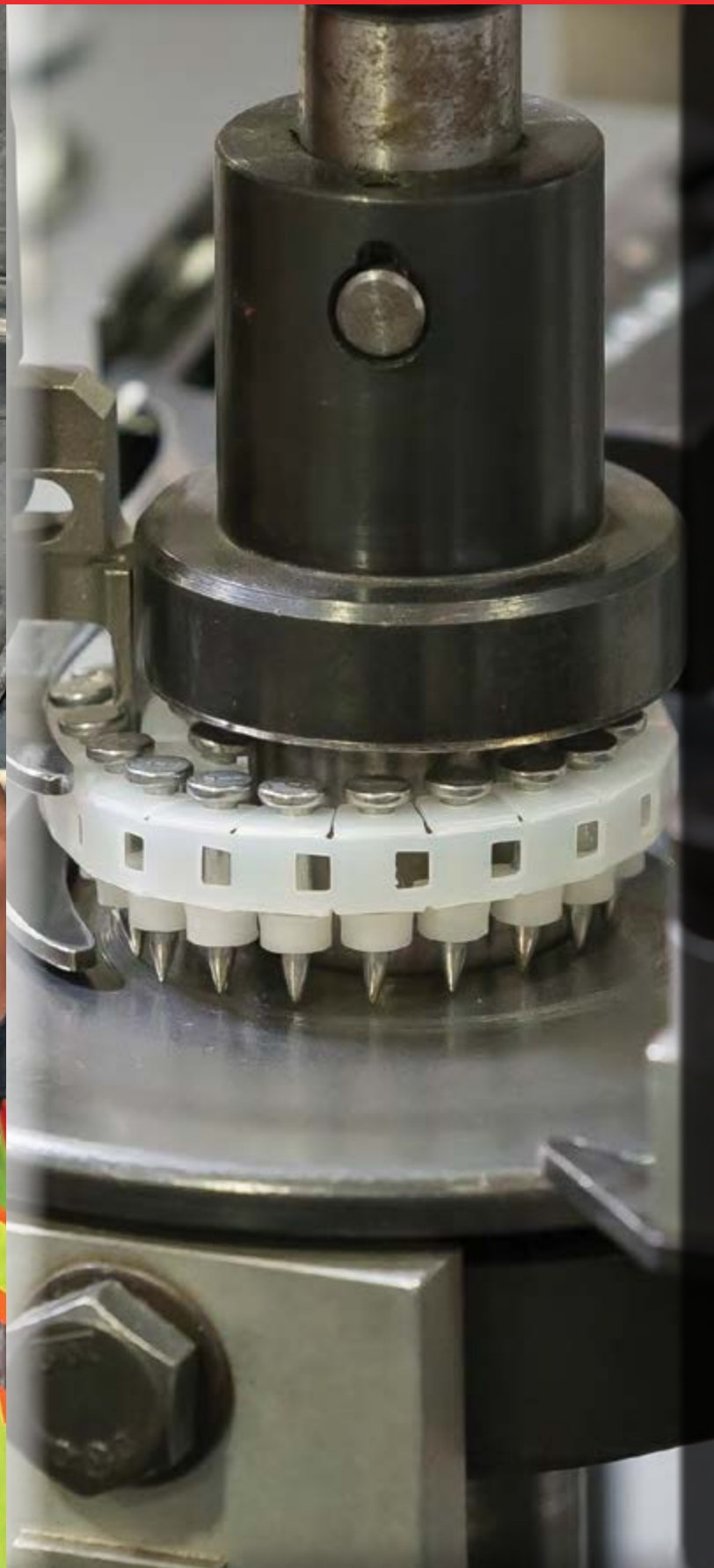

## Defining the Standard for Steel Fastening Applications

Aerosmith<sup>®</sup> introduced the first VersaPin<sup>®</sup> tool in 2003. The ST4200 system continues to change light gauge steel framing. Whenever traditional fastening (screws, nails, bolts, spot welds, etc.) are used, Aerosmith<sup>®</sup> Brand Pins have demonstrated exceptional productivity leaps with speed being the biggest benefit. Now you can do the same job Simply Faster.

## FEATURES & BENEFITS

- ▶ Active Centering Technology:  
Straight drive equaling greater hold values
- ▶ Adjustable Depth Control:  
Consistent drives increase hold values
- ▶ Sequential Trigger:  
Effortless fastening and 7 to 10x faster than screws

## APPLICATIONS

- ▶ eXP<sup>®</sup> / DensGlass<sup>®</sup> / Gypsum Sheathing
- ▶ Fiber Cement Siding to Steel
- ▶ Plywood/OSB to Steel
- ▶ Steel Lath/Foam Board to Steel

**Make sure to turn  
to page 29 for washer  
and magnetic adapter  
options**



**See how pins work in steel:**



## TESTING & REPORTING

ICC-ES 3145 | ICC-ES 5028 | ICC-ES 5030 | FL14885 Tech  
Tech Reports #104, #107, #108





## Building with Cold-Formed Steel? You Need Versatility!

The VersaPin® ST4200 Pin Nailer and its versatile number of fasteners cover multiple applications to Cold Formed Steel. This allows you to bid more and more of the work that's out there on each and every job site. VersaPin®'s speed and durability save Time, Money, and Manpower.



**2385A**



**2352AG**

ITEM	LENGTH	TYPE	CARTON	APPLICATION	STEEL	PLATING
2251AG	1" (25mm)	Helical	3M	Plywood Sheathing and Hardie® Panel	68-54 mil (14-16 ga)	Zinc
2251A	1" (25mm)	Helical	3M	Steel-to-steel	68-54 mil (14-16 ga)	Zinc
2252A	1" (25mm)	Gripshank®	3M	Steel-to-steel	54-43 mil (16-18 ga)	Zinc
2255AG	1" (25mm LH)	Gripshank® PT2000	3M	Hardie® Plank to CFS Furring channel	54-43 mil (16-18 ga)	PT2000
2324A	1 1/4" (32mm LH)	Helical	2.4M	Gypsum Sheathing	68-54 mil (14-16 ga)	Zinc
2325A	1 1/4" (32mm LH)	Gripshank®	2.4M	Gypsum Sheathing	54-43 mil (16-18 ga)	Zinc
2351A	1 3/8" (35mm)	Helical	2M	Plywood Sheathing	68-54 mil (14-16 ga)	Zinc
2351AG	1 3/8" (35mm)	Helical PT2000	2M	Plywood Sheathing including fire treated lumber	68-54 mil (14-16 ga)	PT2000
2352A	1 3/8" (35mm)	Gripshank®	2M	Plywood Sheathing	54-43 mil (16-18 ga)	Zinc
2352AG	1 3/8" (35mm)	Gripshank® PT2000	2M	Plywood Sheathing including fire treated lumber	54-43 mil (16-18 ga)	PT2000
2385A	1 1/2" (38mm LH)	Gripshank®	2M	Plywood Sheathing	54-43 mil (16-18 ga)	Zinc
2385AG	1 1/2" (38mm LH)	Gripshank® PT2000	2M	Hardie® Plank and Plywood Sheathing	54-43 mil (16-18 ga)	PT2000

Helical or Gripshank® Coil Collated Pins (exterior)

Shank Diameter = .100" Large Head Dia. (LH) = .312" Std. Head Dia. = .250" Zinc Galvanized or AG = PT2000 Galvanized.

All steel suggestions are at a minimum 33ksi



### TESTING & REPORTING

ICC-ES 3145 | ICC-ES 5028 | ICC-ES 5030 | FL14885 Tech  
Tech Reports #104, #107, #108

## Pin Fastening is the Faster, Easier, and More Profitable Alternative to Screws

Aerosmith® pins ensure consistent and durable fastening. Aerosmith® pins can be used with a wide variety of coil nailing tools to securely fasten OSB, Plywood, and Cement Siding to Cold Formed Light Gauge Steel.



### FEATURES & BENEFITS

- Collated to fit other tool brands: Reduces user tool cost/investment and opens a wider range of applications
- PT2000 plating option: Superior corrosion resistance

### APPLICATIONS

- Plywood
- OSB
- Fire Treated lumber (PT2000 pins)
- Fiber Cement Panels

ITEM	LENGTH	TYPE	CARTON	STEEL	GROUP	PLATING
2351S	1-3/8"(35mm)	Helical	4 M	68-54(14-16)	S	Zinc
2352S	1-3/8"(35mm)	Gripshank®	4 M	54-43(16-18)	S	Zinc
2352SG	1-3/8"(35mm)	Gripshank®	4 M	54-43(16-18)	S	PT2000
2359NG	1-1/2"(38mm)	SuperSharpy®	3.2 M	43-27(18-22)	N	PT2000
2501S	2"(50mm)	Helical	3 M	68-54(14-16)	S	Zinc
2501SG	2"(50mm)	Helical	3 M	68-54(14-16)	S	PT2000
2502S	2"(50mm)	Gripshank®	3 M	54-43(16-18)	S	Zinc
2502SG	2"(50mm)	Gripshank®	3 M	54-43(16-18)	S	PT2000
2505SBG	2"(50mm) LH	Gripshank®	2.4M	54-43(16-18)	SB	PT2000
2509NG	2"(50mm)	SuperSharpy®	2.4M	43-27(18-22)	N	PT2000
2631SG	2-1/2"(63mm)	Helical	2.4 M	68-54(14-16)	S	PT2000
2635SBG	2-1/2"(63mm) LH	Gripshank®	2.4 M	54-43(16-18)	SB	PT2000
2639NG	2-1/2"(63mm)	SuperSharpy®	2.4 M	43-27(18-22)	N	PT2000

**.100 Series, Knurled Shank Wire & Plastic Coil Collated**  
 Shank Diameter = .100" Zinc Galvanized Head Diameter = .250"  
 AG/SG/SBG Pins = PT2000 LH Diameter = .312"  
 All steel suggestions are at a minimum 33ksi

## 2352S



## 2631SG



**Make sure to turn to page 29 for washer and magnetic adapter options**

### Aerosmith® Pins for your Coil Nailers

#### TOOL GROUP N

Everwin SCN65C Pneu  
CN65S3, JIT JN65S



#### TOOL GROUP S

Everwin SCN65C & FCN90B, Hitachi NV65AC, NV65AH2,  
NV75AG, Interchange: CN565-15, JIT JN65S, Pneu CN65S3



#### TOOL GROUP SB

Everwin FCN90, Grip-Rite,  
GRTC90, Pneu CN90F



### TESTING & REPORTING

ICC-ES 3145 | ICC-ES 5028 | ICC-ES 5030 | FL14885 Tech  
 Tech Reports #104, #107, #108

## WITHDRAWAL VALUES

ITEM	AVERAGE ULTIMATE TOTAL
16 ga. (54mil) (33KSI)	553
18 ga. (43mil) (33KSI)	405.5
20 ga. (33mil) (33KSI)	303.2
20 ga. (33mil) (50KSI)	353.6
22 ga. (27mil)(50KSI)	222.9
22 ga. (27mil) (33KSI)	196.4



### 2359NG



## FEATURES & BENEFITS

- New SuperSharp® point: Greater holding power in lighter gauges of steel providing quick, clean penetration through the truss chord or stud.
- Plastic sheet and plastic stick collation options: Eliminate flagging caused by wire collation and more tool options
- PT2000 plating: Superior protection in applications demanding high corrosion resistance including Pressure Treated and Fire Treated wood products.

ITEM	TOOL	LENGTH	FUEL	TYPE	CARTON	APPLICATION	PLATING
2359NG	N	1-1/2"	NO	SuperSharp®	3.2	Cement Fiber Panel Siding, Plywood, OSB to Steel Plus Steel to Steel	PT2000
2509NG	N	2"	NO	SuperSharp®	2.4	Cement Fiber Panel Siding, Plywood, OSB to Steel	PT2000
2639NG	N	2-1/2"	NO	SuperSharp®	2.4	Cement Fiber Panel Siding, Plywood, OSB to Steel	PT2000
2229DG	D	7/8"	NO	SuperSharp®	1.0	Cement Fiber Panel Siding, Plywood, OSB to Steel Plus Steel to Steel	PT2000
2359DG	D	1-1/2"	NO	SuperSharp®	1.0	Cement Fiber Panel Siding, Plywood, OSB to Steel Plus Steel to Steel	PT2000
2229DGF	D	7/8"	YES	SuperSharp®	1.0	Cement Fiber Panel Siding, Plywood, OSB to Steel Plus Steel to Steel	PT2000
2359DGF	D	1-1/2"	YES	SuperSharp®	1.0	Cement Fiber Panel Siding, Plywood, OSB to Steel Plus Steel to Steel	PT2000

.100 Series GripShank® Supersharpy® Point.

Tool Group N- Plastic Sheet Collation.

Tool Group D- Plastic Strip Collation.

Shank Diameter = .100 Head Diameter = 1/4" GripShank® Knurl

### TOOL GROUP N

EVERWIN SCN65, INTERCHANGE CN565-15, PNEU TOOL CN65S3, HITACHI NV65AH2, JIT JN65S



### TOOL GROUP D

Aerosmith® GT38LI and JIT CS26/38



## TESTING & REPORTING

ICC-ES 5028 | ICC-ES 5030 | FL14885

Tech Reports #104, #105

### Trim Fastening Tools for Wood, Steel, Concrete

In addition to speed and versatility, the aesthetics of a modest head design and the utility of the E-Z clear nose piece make our tools a success. 3-inch fastening requirements can be accommodated and the pins are useful in other applications.

#### FEATURES & BENEFITS

- ▶ 360° adjustable exhaust deflector:  
Reduces dust and debris from being blown into eyes
- ▶ Shock absorbing comfort rubber handle: Less fatigue

#### APPLICATIONS

- ▶ Cement Fiber Trim to Steel
- ▶ Cement Fiber Trim to CMU
- ▶ Wood Trim to CMU
- ▶ Wood Trim to Steel



### ST1850C4 for 15g Fasteners

- Lightweight - only 2.83 lbs
- Depth of drive adjustment
- Easy open magazine for easy loading



### ST2575 for 14g Fasteners

- Lightweight - only 6 lbs
- Drive 1" – 3" Aerosmith® brand finish pins
- Powerful-Drive high pressure concrete

## Steel Trim Pins for Hardie to Steel and Concrete

Hardie® Trim, Wood, or other Composite Board applications are a real challenge when going over Cold-formed Steel, Concrete, and CMU. The same can be said for interior door frames or windows.

### FEATURES & BENEFITS

- High grade hardened steel: Superior shear strength and drive performance
- Minimal head design: Aesthetically pleasing job

### APPLICATIONS

- Cement Fiber Trim to Steel
- Cement Fiber Trim to Concrete and CMU
- Wood Trim to Steel and CMU
- CMU Wood Trim to Steel
- Door frame to Steel



ITEM	TOOL GROUP	HEAD DIAMETER	SHANK DIAMETER & LENGTH	KNURL	PLATING	COLLATION	PRIMARY APPLICATIONS
1200 FINISH	F	.118"	.071 x 2"	Smooth	Zinc	Strip	Trim to LGS or CMU
075-100T FINISH	F	.118"	.075 x 1"	Smooth	Zinc	Strip	Trim to LGS or CMU
075-125T FINISH	F	.118"	.075 x 1-1/4"	Smooth	Zinc	Strip	Trim to LGS or CMU
075-150T FINISH	F	.118"	.075 x 1-1/2"	Smooth	Zinc	Strip	Trim to LGS or CMU
1150T FINISH	T	.276"	.086 x 1-1/2"	Smooth	Zinc	Strip	Trim to LGS or CMU
1175T FINISH	T	.276"	.086 x 1-3/4"	Smooth	Zinc	Strip	Trim to LGS or CMU
1200T FINISH	T	.276"	.086 x 2"	Smooth	Zinc	Strip	Trim to LGS or CMU
1250T FINISH	T	.276"	.086 x 2-1/2"	Smooth	Zinc	Strip	Trim to LGS or CMU
1300T FINISH	G	.276"	.100 x 3"	Smooth	Zinc	Strip	Trim to LGS or CMU

#### TOOL GROUP T

Aerosmith® ST2575, ET&F-210

#### TOOL GROUP G

Aerosmith® ST2575, ET&F: 210T

#### TOOL GROUP F

Aerosmith® ST1850C4, ET&F: 110A

### HN25C High Pressure Pneumatic Tool for Concrete and Steel

The HN25C High Pressure Concrete and Steel Pinner allows you to drive up to 3 layers of 16 gauge steel, 7000 psi concrete, or structural steel. The HN25C weighs less than most finish nailers, with minimal kick-back even in the hardest overhead applications.



\*HN25C is a registered trademark of MAX USA CORP.

### FEATURES & BENEFITS

- ▶ Extremely powerful: Increases the range of applications
- ▶ Ultra Light - Weighing 4.4 lbs.: Reduced worker fatigue and maneuvers in more places to speed up applications
- ▶ High Capacity Magazine: Less reloading
- ▶ Adjustable depth control: Adjustable to ensure the proper set of the pin.
- ▶ No Licensing Required

### APPLICATIONS

- ▶ Track to Steel and Concrete
- ▶ Industrial Applications
- ▶ Resilient Channel to steel
- ▶ Strapping to steel
- ▶ Hat Channel to Concrete and CMU
- ▶ Lath to Concrete and CMU
- ▶ Wood to Steel and Aluminum



## HN120 High Pressure Pneumatic Fastening Tool for High Density Concrete and Heavy Gauge Steel

The HN120 Concrete and Steel Pinner lets you install Aerosmith®'s PowerPin® fasteners with ease; so you can take on the heaviest gauges of Steel or Aluminum. High-density concrete is a breeze with the HN120. Pre or Post tension concrete causes you NO stress whatsoever.

### FEATURES & BENEFITS

- 1" to 2 1/2" capacity: Serves a wide variety of applications
- Superior power: Drives a wide number of applications
- Ultra Light - weighing 6.4 lbs. : Reduces worker fatigue
- No Licensing Required
- No Powder load: No licensing required
- Sequential trigger: Enhanced worker safety



\*HN120 is a registered trademark of MAX USA CORP.

### APPLICATIONS

- Track to Steel/Concrete
- Industrial Applications: RV, Bus, Trucks, and Trailers
- Hardie® to CMU
- Easily fasten Subfloor , Underlayment, and Sleepers to Concrete
- 2x4 to Red Iron Steel and Concrete



### 4 different tips are included with tool



Magnetic Adapter

Flush Drive

Recess Drive

Flush Drive  
(Allows easy pinpoint placement)



## PowerPin® for Heavy Steel or the Densest Concrete

Aerosmith®'s PowerPin® is designed for today's 500 PSI tools. Now you can use the same Aerosmith® fasteners you know and trust for your structural steel and multi-layer steel applications. Designed to work with the HN25 High Pressure Concrete and Steel Pinner and the HN120 High Pressure Concrete and Steel Pinner, PowerPin® is the solution for you. PowerPin® fastening pins are Building Code Tested and Approved and MADE IN THE USA.

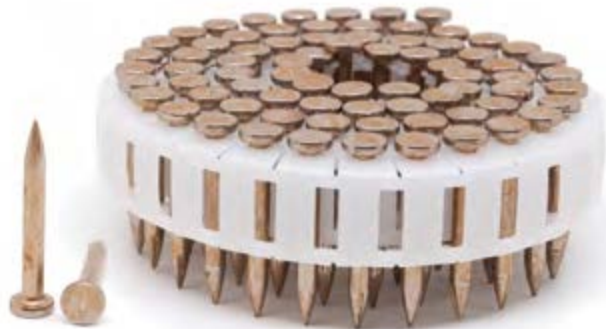

**5323HPG**



**2193HPST**

### FEATURES & BENEFITS

- ▶ Building Code Tested: With ICC and FL Product Approval you can drive PowerPin with confidence
- ▶ Approved for Hardie® to CMU
- ▶ PT2000 plating options: With 2000 Hour Salt Spray testing pressure treated wood and exterior applications are not a problem
- ▶ Available in smooth and helical shanks: The right pin design for your steel and concrete applicaitons

### APPLICATIONS

- ▶ Track to Steel or Concrete
- ▶ Plywood or OSB to Steel or Concrete
- ▶ Hardie to CMU
- ▶ Subfloor Underlayment and Sleepers to Concrete
- ▶ 2x4 to Red Iron, Steel, and Concrete
- ▶ Industrial Applications: RV, Bus, Trucks, Trailers



### TESTING & REPORTING

ICC-ES 3453 | ICC-ESR 3833 | ICC-ES 5032 | LGSRG-2-96 |  
Tech Bulletins #101, #110, #118





ITEM	TOOL GROUP	HEAD DIAMETER	SHANK DIA. & LENGTH	KNURL	PLATING	COLLATION	PRIMARY APPLICATIONS	PACKAGING QTY PER BOX
2191HP	HN25C	.250"	.100 x 3/4"	Helical	Mech Zinc	Plastic Sheet	Light Gauge Steel to Light Gauge Steel	2M
2191HPX	HN25C	.250"	.100 x 3/4"	Helical	Mech Zinc	Plastic Sheet No Grommet	Light Gauge Steel to Light Gauge Steel	2M
2192HP	HN25C	.250"	.100 x 3/4"	GripShank	Mech Zinc	Plastic Sheet	Light Gauge Steel to Light Gauge Steel	2M
2193HP	HN25C	.250"	.109 x 3/4"	Smooth	Mech Zinc	Plastic Sheet	Steel Track and Furring to 2500-4000 Concrete and CMU	2M
2193HPST	HN25C	.250"	.109/.118 x 3/4"	Step Smooth	Mech Zinc	Plastic Sheet	Steel Track to 3,500-6,500 PSI Concrete, Precast Slabs, lintels and steel up to 1/8"	2M
2227HPX	HN25C	.250"	.100 x 7/8"	Helical	Mech Zinc	Plastic Sheet No Grommet	Plywood to Steel up to 14ga	2M
2251HPX	HN25C	.250"	.100 x 1"	Helical	Mech Zinc	Plastic Sheet No Grommet	Plywood to Steel up to 14ga	2M
2257HPX	HN25C	.250" #1 Phillips	.100 x 1"	Helical	Mech Zinc	Plastic Sheet No Grommet	Plywood to Steel up to 12ga	2M
3193HPST	HN25C	.250"	.104/.125 x 3/4"	Step Smooth	Mech Zinc	Plastic Sheet	Steel Track and Furring to 4000-6000 PSI Concrete, Precast Slabs	2M
3193HP	HN25C	.250"	.125 x 3/4"	Smooth	Mech Zinc	Plastic Sheet	Steel Track and Furring to 2000-6000 PSI Concrete and CMU	2M
3488HPE	HN25C	.325" #2 Phillips	.137 x 1-7/8"	Double Knurl	Mech Zinc	Plastic Sheet No Grommet	Steel Track and Furring to 2000-6000 PSI Concrete and CMU	1.5M
5254HP	HN120	.300"	.145 x 1"	Helical	Mech Zinc	Plastic Sheet	Steel to Steel	1.5M
5323HP	HN120	.300"	.145 x 1-1/4"	Smooth	Mech Zinc	Plastic Sheet	Plywood to Concrete and CMU	1.5M
5323HPG	HN120	.300"	.145 x 1-1/4"	Smooth	PT2000	Plastic Sheet	Premium Galvanized for Hardie® and other CFB to CMU	1.5M
5323HPST	HN120	.300"	.145/.128 x 1-1/4"	Step Smooth	Mech Zinc	Plastic Sheet	Plywood to Concrete and Steel up to 1/4"	1.5M
5324HP	HN120	.300"	.145 x 1-1/4"	Helical	Mech Zinc	Plastic Sheet	Plywood to Steel up to 3/16"	1.5M
5324HPG	HN120	.300"	.145 x 1-1/4"	Helical	PT2000	Plastic Sheet	Plywood to Steel	1.5M
5383HP	HN120	.300"	.145 x 1-1/2"	Smooth	Mech Zinc	Plastic Sheet	Plywood to Concrete and CMU	1.5M
5383HPG	HN120	.300"	.145 x 1-1/2"	Smooth	PT2000	Plastic Sheet	Hardie® Artisan® / Plywood to CMU and Concrete	1.5M
5384HP	HN120	.300"	.145 x 1-1/2"	Helical	Mech Zinc	Plastic Sheet	Plywood to Steel up to 3/16"	1.5M
5454HP	HN120	.300"	.145 x 1-3/4"	Helical	Mech Zinc	Plastic Sheet	Cement Fiber Fascia & Plywood to 3/16" Steel	1.5M
5454HPG	HN120	.300"	.145 x 1-3/4"	Helical	PT2000	Plastic Sheet	Cement Fiber Fascia & Plywood to Concrete, CMU or 3/16" Steel	1.5M
5503HP	HN120	.300"	.145 x 2"	Smooth	Mech Zinc	Plastic Sheet	Lumber to Concrete and CMU	1M
5503HPST	HN120	.300"	.145/.128 x 2"	Step Smooth	Mech Zinc	Plastic Sheet	2x to steel up to 1/4"	1.5M
5573HP	HN120	.300"	.145 x 2-1/4"	Smooth	Mech Zinc	Plastic Sheet	2x to steel up to 3/16"	1M
5573HPG	HN120	.300"	.145 x 2-1/4"	Smooth	PT2000	Plastic Sheet	2x PT to Concrete and CMU	1M
5574HP	HN120	.300"	.145 x 2-1/4"	Helical	Mech Zinc	Plastic Sheet	2x lumber to 3/16"	1M
5574HPG	HN120	.300"	.145 x 2-1/4"	Helical	PT2000	Plastic Sheet	2x PT Lumber, Synthetic Rubber & Plywood to steel up to 3/16" and Welded Aluminum Frames	1M
5633HP	HN120	.300"	.145 x 2-1/2"	Smooth	Mech Zinc	Plastic Sheet	2x to Concrete and CMU when using washer	1M
5633HPG	HN120	.300"	.145 x 2-1/2"	Smooth	PT2000	Plastic Sheet	2x PT to Concrete and CMU when using washer	1M

## ST3800 High Pressure Single Shot Pneumatic Tool for Steel

The ST3800 and the associated selection of Hex Head Pins are another Aerosmith® innovation that revolutionized an industry application. Combining the power and performance of High Pressure Pneumatics, rethinking how a HP pneumatic tool can be used and utilizing the knowledge and experience of Aerosmith® designed drive pins, Aerosmith® was able to comply with an industry standard and accelerate production. With performance in steel ranging from 16ga to 1/4" steel, the ST3800 is a versatile tool and pin package.



### FEATURES & BENEFITS

- ▶ Extremely powerful tool: Increases the range of applications
- ▶ Light weight: Reduced worker fatigue; maneuvers in more places to speed up applications
- ▶ Sequential Trigger: Increases safety

### APPLICATIONS

- ▶ Heavy Steel Fastening Commercial
- ▶ Construction Industrial
- ▶ Applications: RV and Bus



## Fasteners for Industrial and OEM Applications

A truly unique combination of Aerosmith® pins and a versatile washer are being used in a number of industrial/OEM applications. A wide diameter washer provides superior holding and pull-thru resistance. Pre-placement of the washer to pin saves time and money. The custom hex-head fastener design makes pin removal easy when using a cordless impact tool, so product maintenance or corrections of manufacturing mistakes are a breeze. Saves you time, money, and materials.

### 5223HHF



## FEATURES & BENEFITS

- ▶ Hex head design: Easy removal for maintenance or mistakes
- ▶ Fastener guided through installation: Results in a quality application A wide, galvanized washer:
- ▶ Superior holding and pull through resistance Smooth or helical shank designs:
- ▶ Improved drivability and holding power

## APPLICATIONS

- ▶ Easily fasten to tube steel and more.
- ▶ Fasten composite materials with the holding and pull through resistance from the pre-assembled washer-pin combination.
- ▶ Hex Head pin design eases pin removal for after-market maintenance or mistake correction

ITEM	DESCRIPTION	QTY/BOX
5223HHF	.145 x 7/8" Smooth Hex Head w/Washer	1,500
5224HHF	.145 x 7/8" Helcal Hex Head w/Washer	1,500

### Surepin® CT90 Nailer Pinner for Plywood to Steel and Concrete

Aerosmith® SurePin® CT90 tools have been successfully fastening plywood and OSB to concrete and wood to heavy steel for more than 40 years. No more powder, no more black mastic with its harmful fumes, no more pre-drilling into heavy steel. Aerosmith® SurePin® Fasteners have demonstrated exceptional productivity leaps with speed being the biggest benefit. Now you can do the job Simply Faster.

#### FEATURES & BENEFITS

- Powerful: The best method for fastening Plywood, 1x's, 2x's and more to Concrete
- Intelligently Designed: The flat front and a rear magazine allow you to operate closer to walls
- Precision depth control: Drive the pins with confidence
- Large tool magazine: Less down time re-loading
- No special training or licensing
- Made in the USA

#### APPLICATIONS

- Plywood Subfloor to Concrete for Hardwood
- Flooring Cement Fiber Siding to CMU
- 2x4 to Steel and Concrete



See page 33 for our specially modified compressor to run the CT90 at peak performance.



The Premier tool for subfloor attachment to concrete in the hardwood flooring industry.



#### TESTING & REPORTING

ICC-ES 3453 | ICC-ES 5032 | LGSRG-2-96 |  
Tech Bulletins #101, #110, #118

## Fast, Secure Connection to Steel and Concrete

Whether it's sub-floor to concrete, sleepers to concrete or 2x4 to steel Aerosmith®'s SurePin® Fasteners will provide you with a fast, secure and reliable connection. Aerosmith® SurePin® fasteners are Code Approved and Made in the USA.

### 5323P



## FEATURES & BENEFITS

- Code Compliant: ICC tested providing confidence in the pin performance
- Approved for Hardie® siding to CMU
- PT2000 plating options: Superior corrosion resistance for pressure treated and exterior applications

## APPLICATIONS

- Plywood Subfloor to Concrete for Hardwood Flooring
- Cement Fiber Siding to CMU
- 2x4 to Steel and Concrete



ITEM	TOOL GROUP	HEAD DIAMETER	SHANK DIAMETER & LENGTH	KNURL	PLATING	COLLATION	PRIMARY APPLICATIONS	PACKAGING QTY PER BOX
5254P	CT90	.300"	.144 x 1"	Knurled	Zinc	Plastic Strip	Plywood to Steel	3.2M
5323P	CT90	.300"	.144 x 1-1/4"	Smooth	Zinc	Plastic Strip	Plywood to Concrete	1M
5324P	CT90	.300"	.144 x 1-1/4"	Knurled	Zinc	Plastic Strip	Plywood to Steel	2.4M
5383P	CT90	.300"	.144 x 1-1/2"	Smooth	Zinc	Plastic Strip	Plywood to Concrete	1M
5574PG	CT90	.300"	.144 x 2-1/4"	Knurled	Zinc	Plastic Strip	2 x 4 to Steel	2.4M
5454PG	CT90	.300"	.144 x 1-3/4"	Knurled	PT2000	Plastic Strip	Plywood to Steel	3.2M
5573PG	CT90	.300"	.144 x 2-1/4"	Smooth	PT2000	Plastic Strip	2 X to Concrete	2.4M



**TESTING & REPORTING**  
 ICC-ES 3453 | ICC-ES 5032 | LGSRG-2-96 |  
 Tech Bulletins #101, #110, #118

### For Attaching Insulation to Steel, CMU or Concrete

Aerosmith® developed the GT38LI-EXIF, GT60LI-EXIF, and AT150 tools to help you SAVE TIME and MONEY when installing insulation to light gauge steel, CMU, or concrete. The “GT” series tools provide cordless high performance, which features a lithium-ion battery, is simple to use, and easily installs 1” to 6” plastic washers. The tool features a quick-release barrel that makes storage super simple! The AT150 compliments our tool offering with a 100 PSI pneumatic option that handles hard concrete and light gauge steel with ease. Perfect for enclosed environments and extreme cold.

### FEATURES & BENEFITS

- ▶ Lithium Ion Battery: 8000 drives per charge
- ▶ Fast charge: 1 Hour recharge time to keep you running
- ▶ Fuel Cell Delivers 1000 drives
- ▶ Quick Release Barrel
- ▶ Most Powerful Tool On The Market
- ▶ Pneumatic option: The choice for enclosed spaces

### APPLICATIONS

- ▶ Insulation to Steel, Concrete, and CMU



**GT38LI EXIF**



**AT150**



**GT60LI EXIF**

AT 150 Tool  
 No case – Box contains tool and barrel. Air fitting is purchased separately.

GT Series Tools Inside the case:  
 Tool, 2 Lithium-Ion Batteries, Charger, Safety Glasses

## Need both Power and Speed? Then you need Aerosmith®'s Insulation tools and washers.

Aerosmith®'s EXIF fasteners will do the job, working with the new GT38LI-EXIF, GT60LIEXIF Gas Tools, and the AT150 100 PSI Air Tool. Easily installs various types of insulation materials to concrete, CMU or LGS up to 12 gauge. You'll also improve your efficiency with easy loading time and less time on the wall.

### FEATURES & BENEFITS

- 60MM head diameter: Securely hold most types of rigid or semi rigid insulation
- Integrated cap: Snap in place to increase thermal performance
- Integrated pins: Simply slide the fully integrated washer over the barrel. Smooth for concrete and CMU and Helical for steel
- Color coded: White for concrete and Gray for steel
- Aerosmith® name and washer size visible on head.
- Washer shank designed to prevent cracking



### APPLICATIONS

- Insulation to Steel, Concrete, and CMU

**DOES NOT INCLUDE THE FUEL CELL**  
(see page 34 for 2 options on fuels cells)

P/N	TOOL GROUP	HEAD DIAMETER	SHANK TYPE	ANCHOR LENGTH	PRIMARY APPLICATIONS	BOX QYT.
GT100ICBB	GT38-60L EXIF / AT150	60MM	Smooth Step	1"	RIGID/SEMI RIGID INSULATION TO CONCRETE / CMU	1200
GT112ICBB	GT38-60L EXIF / AT150	60MM	Smooth Step	1-1/2"	RIGID/SEMI RIGID INSULATION TO CONCRETE / CMU	1200
GT200ICBB	GT38-60L EXIF / AT150	60MM	Smooth Step	2"	RIGID/SEMI RIGID INSULATION TO CONCRETE / CMU	950
GT212ICBB	GT38-60L EXIF / AT150	60MM	Smooth Step	2-1/2"	RIGID/SEMI RIGID INSULATION TO CONCRETE / CMU	880
GT300ICBB	GT38-60L EXIF / AT150	60MM	Smooth Step	3"	RIGID/SEMI RIGID INSULATION TO CONCRETE / CMU	760
GT312ICBB	GT38-60L EXIF / AT150	60MM	Smooth Step	3-1/2"	RIGID/SEMI RIGID INSULATION TO CONCRETE / CMU	660
GT400ICBB	GT38-60L EXIF / AT150	60MM	Smooth Step	4"	RIGID/SEMI RIGID INSULATION TO CONCRETE / CMU	580
GT500ICBB	GT38-60L EXIF / AT150	60MM	Smooth Step	5"	RIGID/SEMI RIGID INSULATION TO CONCRETE / CMU	480
GT600ICBB	GT38-60L EXIF / AT150	60MM	Smooth Step	6"	RIGID/SEMI RIGID INSULATION TO CONCRETE / CMU	400

P/N	TOOL GROUP	HEAD DIAMETER	SHANK TYPE	ANCHOR LENGTH	PRIMARY APPLICATIONS	BOX QYT.
GT100ISBB	GT38-60L EXIF / AT150	60MM	Helical	1"	RIGID/SEMI RIGID INSULATION TO LGS/CFS	1200
GT112ISBB	GT38-60L EXIF / AT150	60MM	Helical	1-1/2"	RIGID/SEMI RIGID INSULATION TO LGS/CFS	1100
GT200ISBB	GT38-60L EXIF / AT150	60MM	Helical	2"	RIGID/SEMI RIGID INSULATION TO LGS/CFS	950
GT212ISBB	GT38-60L EXIF / AT150	60MM	Helical	2-1/2"	RIGID/SEMI RIGID INSULATION TO LGS/CFS	880
GT300ISBB	GT38-60L EXIF / AT150	60MM	Helical	3"	RIGID/SEMI RIGID INSULATION TO LGS/CFS	760

## Track to Concrete / Steel Nail Guns

Aerosmith® Fastening's new GT38LI (90J) and GT60LI (105J) Gas Track Pinners are quality, high performance gas powered tools that allow tracking to concrete, block or steel. The GT38LI and GT60LI, which uses TraxPin fasteners, will also improve your efficiency with less loading time and 8000 drives per fully charged battery.

### FEATURES & BENEFITS

- ▶ Lithium Ion Battery: 8000 drives per charge
- ▶ 1/2" to 1 1/2" pin length capacity: Fasten a wide range of applications
- ▶ Fast Charge: 1 Hour recharge time to keep you running
- ▶ Quick Release Magazine: Easily maintain the tool
- ▶ Fuel Cell Delivers 1000 Drives: Enough to drive a full box of pins
- ▶ Powerful: Handles the hardest applications

### APPLICATIONS

- ▶ Track to Steel, Concrete, and CMU
- ▶ Plywood or OSB to Light Gauge Steel, Concrete, and CMU
- ▶ Hat channel and other furring materials to Concrete, and CMU
- ▶ Light Gauge Steel to Light Gauge Steel

#### INSIDE THE CASE:

**TOOL, 2 Lithium Ion Batteries,  
Battery Charger, Safety Glasses.**

### TESTING & REPORTING

ICC-ESR 4481



**GT38LI**



**GT60LI**



## TraxPin® for Steel, Light Gauge Steel, Concrete, and CMU

Aerosmith®'s TraxPin® fasteners fit the Aerosmith® GT38LI and GT60LI Gas Track Pinners, as well as many 100 P.S.I pneumatic track tools. Fasten to Steel, Light Gauge Steel, Concrete, and CMU with our ICC tested fasteners.

### GT034PFP



1000 pins per inner box, includes one fuel cell

TraxPin® fasteners fit many pneumatic track tools, like the JIT CS26/38.

### FEATURES & BENEFITS

- 5000 pins per case: Each case contains 5 inner boxes
- Fuel cell delivers 1000 drives: Designed to drive an entire box
- Pins available in 1/2" to 1-1/2" lengths: Handles multiple applications
- Premium 1/2" Step Shank pin: Superior driveability in structural steel
- SuperSharp® options: Connect confidently to Light Gauge Steel

### APPLICATIONS

- Track to Steel/Concrete
- Plywood or OSB (Oriented Strand Board) to Concrete and CMU
- Hat channel and other furring materials to Concrete and CMU
- Light Gauge Steel to Light Gauge Steel
- Fiber Cement Panels to Light Gauge Steel

ITEM	FUEL	HEAD DIAMETER	SHANK DIAMETER & LENGTH	KNURL STYLE	PLATING	COLLATION STYLE	PRIMARY APPLICATIONS	PACKAGING QTY PER BOX IN M'S
GT012PFP	Included	.250"	.102" x .120" X 1/2"	Smooth Step	Zinc	Plastic Strip	Track to Steel	1000
GT034FP	Included	.250"	.102" X3/4"	Smooth	Zinc	Plastic Strip	Track and Lath to Concrete and CMU	1000
GT034PFP	Included	.250"	.102" x .120" X 3/4"	Smooth Step	Zinc	Plastic Strip	Track and Lath to hard Concrete and CMU	1000
GT100FP	Included	.250"	.102" x 1"	Smooth	Zinc	Plastic Strip	Wood and Lath to Concrete and CMU	1000
GT114FP	Included	.250"	.102" x 1-1/4"	Smooth	Zinc	Plastic Strip	Wood and Waterproofing to Concrete and CMU	1000
GT112FP	Included	.250"	.102" x 1-1/2"	Smooth	Zinc	Plastic Strip	Wood to Concrete and CMU	1000
2229DGF	Included	.250"	.100" X 7/8"	SuperSharp®	PT2000	Plastic Strip	Light Gauge Steel to Light Gauge Steel	1000
2359DGF	Included	.250"	.102" X 1 1/2"	SuperSharp®	PT2000	Plastic Strip	Sheathing to Light Gauge Steel	1000
PBC30151000	Not Included	.250"	.102" x 1-1/2"	Smooth Step	Zinc	Plastic Strip	Track to Steel	1000
PBC30191000	Not Included	.250"	.102" x 1-1/2"	Smooth Step	Zinc	Plastic Strip	Track and Lath to hard Concrete and CMU	1000
RBC26191000	Not Included	.250"	.102" x 1-1/2"	Smooth	Zinc	Plastic Strip	Track and Lath to Concrete and CMU	1000
RBC26251000	Not Included	.250"	.102" x 1-1/2"	Smooth	Zinc	Plastic Strip	Wood and Lath to Concrete and CMU	1000
RBC26321000	Not Included	.250"	.102" x 1-1/2"	Smooth	Zinc	Plastic Strip	Wood and Waterproofing to Concrete and CMU	1000
RBC26381000	Not Included	.250"	.102" x 1-1/2"	Smooth	Zinc	Plastic Strip	Wood to Concrete and CMU	1000
2229DG	Not Included	.250"	.102" x 1-1/2"	SuperSharp®	PT2000	Plastic Strip	Light Gauge Steel to Light Gauge Steel	1000
2359DG	Not Included	.250"	.102" x 1-1/2"	SuperSharp®	PT2000	Plastic Strip	Sheathing to Light Gauge Steel	1000

ALL ITEMS ABOVE ARE 1M TO A BOX AND 5M TO A CASE - EACH 1M BOX CONTAINS ONE FUEL CELL



### TESTING & REPORTING

ICC-ESR 4481 | Tech Bulletin #118

# SPECIALTY PINS



## The Best Just Got Better - The New Gold Standard for High Corrosion Conditions

PROTOCOL	AEROSMITH ACQ FASTENER	NAME BRAND HOT DIP GALVANIZED	MULTI ELECTRO GALVANIZED	OTHER MISC. WEATHER/CORROSION RESISTANT COATINGS
ASTM B117	2000	642	376	458
ASTM B117 Modified (Fasteners Driven and Treated into ACQ rated board)	1656	412	N/A	180
Fasteners Immersed directly into 6% ACQ Solution	125	43	48*	24

### FEATURES & BENEFITS

- Code approved for Fire Treated Lumber
- Superior corrosion performance in Pressure Treated wood
- Top choice for Coastal regions
- Exceptional corrosion resistance retained after fasteners are driven
- The speed, value and variety of Aerosmith® Fastening Systems

### APPLICATIONS

- Hardie® and other CFB materials
- Fire Treated Lumber
- Pressure Treated Woods
- Coastal Applications
- Attachment to Aluminum



#### TOOL GROUP A

Aerosmith® – ST4200

#### TOOL GROUP N

Everwin SCN65C, Pneu CN65S3, JIT JN65S

#### TOOL GROUP SB

Everwin FCN90B, CN90F, Max CN890F2, Pneu Tool

#### TOOL GROUP S

Everwin SCN65C & FCN90B, Hitachi NV65AC, NV65AH2, NV75AG, Interchange: CN565-15, JIT JN65S, Pneu CN65 S3

## VERSAPIN®



ITEM	LENGTH	KNURL	MIL (GAUGE) 33KSI	CARTON	TOOL GROUP
2251AG	1" (25mm)	Gripshank®	54-43 (16-18)	2M	A
2255AG	1" (25mm)	Gripshank®	54-43 (16-18)	3M	A
2352SG	1-3/8" (35mm)	Gripshank®	54-43 (16-18)	4M	S
2359NG	1-1/2" (38mm)	Gripshank® SuperSharpy®	54-27 (16-22)	3.2M	N
2385AG	1-1/2" (38mm)	Gripshank®	54-43 (16-18)	2M	A
2501SG	2" (50mm)	Helical	97-54 (12-16)	3M	S
2502SG	2" (50mm)	Gripshank®	54-43 (16-18)	3M	S
2505SBG	2" (50mm)	Gripshank®	54-43 (16-18)	2.4M	SB
2509NG	2" (50mm)	Gripshank® SuperSharpy®	54-27 (16-22)	2.4M	N
2631SG	2-1/2" (63mm)	Helical	97-54 (12-16)	2.4M	S
2639NG	2-1/2" (63mm)	Gripshank® SuperSharpy®	54-27 (16-22)	2.4M	N
2635SBG	2-1/2" (63mm)	Gripshank®	54-43 (16-18)	2.4M	SB

.100 Series Knurled Shank Wire Coil and Plastic Sheet Collated  
 Shank Diameter = .100" | Std. Head Diameter = .250"  
 Lrg. Head Diameter 2255AG/2385AG/2505SBG/2635SBG = .312 | PT2000 Plating

### APPROVALS

Code approved for Fire Treated Lumber

## PowerPIN®



**Fits HN120 HP Tool**

ITEM	LENGTH	KNURL	MIL (GAUGE) 33KSI	CARTON	COIL SIZE
5323HPG	1 1/4" (32MM)	Smooth	54-43 (16-18)	1.5M	75
5324HPG	1 1/4" (32MM)	Helical	54-43 (16-18)	1.5M	75
5383HPG	1 1/2" (38MM)	Smooth	54-43 (16-18)	1.5M	75
5454HPG	1 3/4" (45MM)	Helical	54-27 (16-22)	1.5M	75
5573HPG	2 1/4" (57MM)	Smooth	54-43 (16-18)	1M	50
5574HPG	2 1/4" (57MM)	Helical	97-54 (12-16)	1M	50
5633HPG	2 1/2" (63MM)	Smooth	54-43 (16-18)	1M	50

.144 Series Smooth and Helical Shank Plastic Sheet Collation-  
Shank Diameter = .144" | Head Diameter = .300" | PT2000 Plating

ITEM	LENGTH	KNURL	CARTON	COLLATION
5454PG	.144 x 1-3/4"	Helical	3.2M	Plastic Strip
5573PG	G .144 x 2-1/4"	Smooth	2.4M	Plastic Strip
5574PG	2-1/4" (57mm)	Helical	2.4M	Plastic Strip

.144 Series Smooth and Helical Shank Plastic Strip  
Shank Diameter = .144" | Head Diameter = .300" | PT2000 Plating

## SUREPIN®



## TraxPIN®

### TOOL GROUP D

Aerosmith® GT38LI and GT60LI  
JIT CS26/38



ITEM	TOOL GROUP	LENGTH	INCLUDES FUEL	KNURL STYLE	PLATING	COLLATION STYLE	APPLICATIONS	PACKAGING QTY PER BOX IN M'S
2229DG	D	7/8"	NO	SuperSharp®	PT2000	Plastic Strip	Light Gauge Steel to Light Gauge Steel	1000
2359DG	D	1-1/2"	NO	SuperSharp®	PT2000	Plastic Strip	Sheathing to Light Gauge Steel	1000
2229DGF	D	7/8"	YES	SuperSharp®	PT2000	Plastic Strip	Light Gauge Steel to Light Gauge Steel	1000
2359DGF	D	1-1/2"	YES	SuperSharp®	PT2000	Plastic Strip	Sheathing to Light Gauge Steel	1000

Shank Diameter = .100" | Head Diameter = .250" PT2000 Plating | Plastic Strip Collation

## Steel Washers

Aerosmith® Steel Washers are approved for use with Aerosmith® Fastening Systems' VersaPin® PowerPin® fasteners to attach wire lath, and/or insulation board products to steel or concrete.

### FEATURES & BENEFITS

- Unique, round plate design with the outside circumference beveled up
- A round washer with beveled edge allows for better surface contact, less potential countersink and a more secure fastening
- Round shape design evenly distributes bearing load without any sharp edges or corners, minimizing damage to facer or insulation
- Seated plate with zero profile and will not catch the edge of a trowel when applying stucco to wire lath
- "Grip-Guard" Galvalume coating offers greater protection than silver zinc electroplating

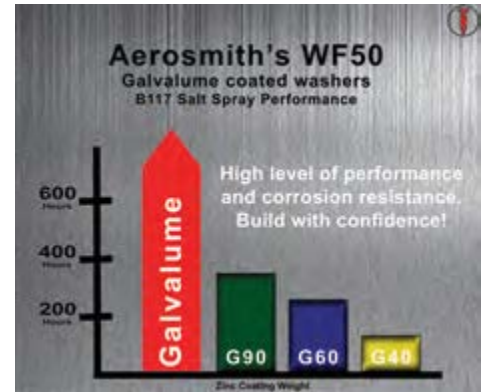

## WF50 1-1/4" Steel Washer

Aerosmith's steel washers (WF50) are used to attach gypsum to light gauge steel as well as metal and synthetic lath to light gauge steel / concrete / CMU as part of the stucco system. The WF50 washer is galvanized to help protect against "bleed through" stain and it is "keyed" to provide extra holding power for the stucco system. Made in the USA. Combine the Aerosmith® WF50 washer with any Aerosmith® pin, the ST4200 air tool, many siding and framing coil tools and HP tools with our magnetic tool adapters for a quick and secure installation.

ITEM	WF50
------	------



## UNM4200 Magnetic Adapter for ST4200

The magnetic adapter (UNM4200) fits easily and securely to the nose piece of the VersaPin® ST4200 Pneumatic Nailer or the optional magnetic nose piece (494-M10) for the SurePin CT90 air tool. The magnetic nose piece enables the pre-loading of a consistently 'centered', 1-1/4" diameter, galvanized steel washer for their fast, repetitive installation. The aggressive magnet holds washers securely for accurate placement over the material and substrate while enabling the user to reach out over wider areas of application.

ITEM	UNM4200
------	---------



## Magnetic Adapters

\*Magnetic adapters to hold and deliver Aerosmith® WF50 1 1/4" Lath washers are available to fit the Aerosmith®'s VersaPin™, ST4200 and a wide selection of siding and framing coil tools.

ITEM	TOOL
UNM4200A	Aerosmith® ST4200
UNM565	MAX CN565S
UNM65	Pneu Tool CN65S-3
UNM90	Pneu Tool CN90F



\*Tools above are examples. Contact Aerosmith® to see if any fit your tool.

## Magnetic Adapters & Washers

Aerosmith® ingenuity brings you an array of different tool adapters that not only increase the number of applications where you can use Aerosmith® pins, but also makes jobs more productive.

### GTMLA Magnetic Adapter for GT38LI

The magnetic adapter (GTMLA) fits easily and securely over the nose of the Aerosmith® GT38LI tool for lath applications. The GTMLA accepts 1" diameter galvanized steel washers. The aggressive magnet holds washers securely for placement over the material and substrate while enabling the user to reach out over wider areas of application.



ITEM	GTMLA
------	-------

### GTMLA2 Magnetic Adapter for GT60LI

The magnetic adapter (GTMLA2) fits easily and securely over the nose of the Aerosmith® GT60LI tool for lath applications. The GTMLA2 accepts 1" diameter galvanized steel washers. The aggressive magnet holds washers securely for accurate placement over the material and substrate while enabling the user to reach out over wider areas of application.



ITEM	GTMLA2
------	--------

### GTLW 1" Lath Washer

The GTLW 1" galvanized washer fits the Aerosmith® GTMLA and GTMLA2 magnetic adapters and other 1" magnetic adapters. The perforations in the washer help exterior coatings, like stucco, to adhere.



ITEM	GTLW
------	------

## 196 Parts Kit for repair

PARTS KIT-195 -COMPLETE RUBBER REPLACEMENT		
QTY	PART NUMBER	DESCRIPTION
1	210	PILOT VALVE SEAL
1	211	MAIN VALVE SEAT
2	212	EXHAUST SEAL
1	238	GASKET SEAL
3	239	GASKET SEAL
1	240	GASKET SEAL
1	272	VALVE STEM SEAL
1	253	BUMPER
1	314	PISTON/RETURN DIAPHRAGM ASSY
1	368	SPRING-TRIGGER BUSHING
1	383	MAIN VALVE GUIDE
1	386	VAL VE STEM SEAL
1	387	SPRING- TOUCH VALVE
1	430	SEAL. SLIDE END PLATE
1	432	SPRING. NAIL SLIDE
1	140-0401	SEAL-NAIL SLIDE
2	2-016	O-RING
2	2-018	O-RING
2	2-115	O-RING
1	2-230	O-RING
1	2-236	O-RING
2	2-238	O-RING

## 197 Parts Kit for repair

PARTS KIT-195 -COMPLETE RUBBER REPLACEMENT		
QTY	PART NUMBER	DESCRIPTION
1	210	PILOT VALVE SEAL
1	211	MAIN VALVE SEAT
2	212	EXHAUST SEAL
1	238	GASKET SEAL
3	239	GASKET SEAL
1	240	GASKET SEAL
1	272	VALVE STEM SEAL
1	253	BUMPER
1	314	PISTON/RETURN DIAPHRAGM ASSY
1	368	SPRING-TRIGGER BUSHING
1	383	MAIN VALVE GUIDE
1	386	VAL VE STEM SEAL
1	387	SPRING- TOUCH VALVE
1	430	SEAL. SLIDE END PLATE
1	432	SPRING. NAIL SLIDE
1	140-0401	SEAL-NAIL SLIDE
2	2-016	O-RING
2	2-018	O-RING
2	2-115	O-RING
1	2-230	O-RING
1	2-236	O-RING
2	2-238	O-RING



## 196 Parts Kit for repair

PARTS KIT - 196 - BASIC REPAIR		
QTY	PART NUMBER	DESCRIPTION
1	210	PILOT VALVE SEAL
1	314	PISTON/RETURN DIAPHRAGM ASSY
1	140-041	SEAL-NAIL SLIDE
1	2-230	O-RING
1	2-236	O-RING
2	2-238	O-RING
2	2-016	O-RING
2	2-018	O-RING
2	2-115	O-RING



## Nose Pieces for CT90

These nose pieces are designed to accommodate 0.145" diameter pins and are especially effective for installing longer type fasteners. Pins associated with each nose piece can then either be left flush to your material or countersunk either 1- or 2-pin head thicknesses depending on the nose piece selection. Diameters of the nose pieces are either 2" or 1-5/16" and can be selected based on the application needs.

Nose pieces for the CT90 are interchangeable to fit the CT90 air tool allowing for a prescribed depth of drive feature.

ITEM	DESCRIPTION
494	Flush Set
494-1	Recess one head depth deeper
494-2	Recess two head depth deeper



## AKHL 1260E & AKHL 1260EX Compressors

For the HN25C High Pressure Concrete and Steel Pinner, HN120 High Pressure Concrete and Steel Pinner

Powerful, lightweight at 35.4 /51.1 lbs, and quiet are just a few descriptions used for the AKHL1260E and AKHL1260EX compressors. With two sets of air fittings these compressors can serve two 100 PSI air tools like the ST4200 and/or two high-pressure tools like the HN25C High Pressure Concrete and Steel Pinner, HN120 High Pressure Concrete and Steel Pinner. Powered by a 115v, 12A, oil-less, AC to DC inverter brushless motor, allows the units to operate on a standard jobsite electrical circuit and with extension cords without damage.



ITEM AKHL1260E



ITEM AKHL1260EX

## High Pressure Hose for PowerPin®

High pressure hose and fittings are designed exclusively for High Pressure tools (uses 250psi to 450psi). Hoses are 30mm in diameter, and available in either 50' or 100'



ITEM	LENGTH
KHL100FT	100
KHL50FT	50

## HP175 7/8" Washer

ITEM HP175



## ZT99983 Magnetic Adapter

ITEM ZT99983





**Dual Setting Compressors for Power, Speed, and Time!**

## UNK15E Compressor for CT90 Air Tools

The 1.5HP electric motor on the UNK15E compressor delivers 7.3 CFM of air runs off a 20 amp breaker and can serve dual Aerosmith® CT90 air tools. It's easy and fast to maneuver on the job because of its wheel barrow-type platform.

The pump is a heavy duty, single stage, cast-iron, twin cylinder power source that is 'splash-oiled'.

Big jobs require big air tools, and Aerosmith's UNK15E compressor provides lots of air when you need, using either 50' or 100' air hose.

ITEM

UNK15E



## UNAC4100-C Air Pressure Booster for CT90 Air Tools

Boost inlet air pressure up to 170 PSI and regulate any air system, using this simple and reliable device.

**MADE TO ORDER**

ITEM

UNAC4100-C



## GTCHR2 Battery Charger for GT38LI & GT60LI Series Tools

ITEM GTCHR2



## GTBAT2 LI-ION Battery for GT38LI & GT60LI Series Tools

ITEM GTBAT2



## GTFUEL2 Gas Fuel Cell 2-pack for GT38LI & GT60LI Series Tools

ITEM GTFUEL2



## GTFUEL12 Gas Fuel Cell 12-pack for GT38LI & GT60LI Series Tools

ITEM GTFUEL12



# MECHANICAL AND ADHESIVE ANCHORING



# INDEX

## Heavy Duty Mechanical Anchors

Sure-Wedge® Carbon Steel Wedge Anchors (ICC-ES Listed for Cracked and Uncracked Concrete Category 1) Report # ESR-4413	39
Carbon Steel Wedge Anchors	40
304 Stainless Steel Wedge Anchors	41
316 Stainless Steel Wedge Anchors	42
Sure-Bolt® Concrete Screw Bolts (ICC-ES Listed for Cracked and Uncracked Concrete Category 1) Report # ESR-4414	43
Sure-Bolt® Extreme Concrete Screw Bolts and 304 Stainless Steel Sleeve Anchors	43
Sleeve Anchors	44
Caulking Anchors	45
Drop-in Anchors (Carbon Steel, 304 and 316 SS, Coil Thread, Shallow Embedment)	46
Hollow Block Anchors	47
Dual Machine Bolt Anchors	48
Machine Bolt Anchors	48
Sure-Lag	49
SDS-Plus Carbide Drill Bits	50

## Medium to Light Duty Mechanical Anchors

Strike Anchors	52
Sure-Con® Concrete Screws Blue and White	53
Sure-Con® 410 Stainless Steel Sure-Cons®	54
Sure-Con® Concrete Screw Bits	55
Hangerz	56
Sockets	57
Zinc Nail-in Anchors	58
Zinc Removable Nail-in Anchors and Split Drive Anchor	59
Split Drive Anchor	59

## Cast in Place Anchors

Blue Banger Hangers™	61/62
----------------------	-------

## Drywall and Hollow Cavity Anchors

Toggle Bolts and Wings	64
Nylon & Zinc Drywall Anchors	65
Nylon Drywall Toggles	65

## Adhesive Anchoring

Sure-Set® Pure Epoxy	67
Sure-Set® ACR-28 and CIC1200A	69

# HEAVY DUTY MECHANICAL EXPANSION ANCHORS

## Sure-Wedge® ICC-ES Listed



Aerosmith®'s Sure Wedge® is a torque-controlled, mechanical expansion anchor, consisting of an anchor body, expansion clip, nut and washer. The anchor body has a tapered mandrel formed on the installed end of the anchor and a threaded section at the opposite end. Suitable base materials include, normal weight concrete and lightweight concrete. The anchors are used to resist static; wind and seismic tension and shear loads in cracked and uncracked normal weight and lightweight concrete having a specific compressive strength of 2500 PSI to 8500 PSI. The anchor is manufactured with a zinc plated carbon steel body and sherardized clip that wraps around the mandrel, rotating freely before installation.

## Wedge Anchor Carbon Steel



Aerosmith®'s Wedge Anchor is a threaded, torque-controlled, carbon steel wedge expansion anchor. It is designed for consistent performance in solid concrete or grout filled concrete masonry. The anchor is made of a carbon steel body and expansion clip. Anchor is driven into pre-drilled hole which is the same diameter of the anchor body. Threaded studs are then set by tightening the nut to the required torque value for optimum performance. To help identify the length of an installed anchor, an identification code has been developed. A letter is stamped on the end of the threaded portion of the anchor so that the length can be easily determined after installation. This letter corresponds to the overall length of the anchor (in inches).

## Wedge Anchor 304 SS



Aerosmith®'s Wedge Anchor type 304 Stainless Steel is a threaded, torque-controlled, stainless steel wedge expansion anchor. It is designed for consistent performance in normal and lightweight concrete. The anchor body, clip, nut and washer are made of 304 Stainless Steel. Drill same diameter hole into concrete as the anchor body and drive anchor through fixture into pre-drilled hole, tighten to required torque value.

## Wedge Anchor 316 SS



Aerosmith®'s Wedge Anchor grade 316 Stainless Steel is a threaded, torque-controlled, stainless steel wedge expansion anchor and is designed for consistent performance in concrete. The anchor, clip, nut and washer are made of Type 316 Stainless Steel. Drill same diameter hole into concrete as the anchor body and drive anchor through fixture into pre-drilled hole.

## Sure-Bolt® ICC-ES Listed



Aerosmith®'s Sure Bolt® is a one-piece, heavy duty screw anchor with a finished hex head. The anchor is manufactured from carbon steel and is heat treated. The Sure-Bolt® is available in a variety of sizes from 1/4 to 3/4 inch. The hex head diameter is larger than the diameter of the anchor and is formed with serrations on the underside. The anchor can be installed in a pre-drilled hole with a powered impact wrench or a torque wrench. The anchor threads cut into concrete on the sides of the hole and interlock with the base material during the installation. Once installed they are easily identifiable by head markings with ASF on the head. Suitable base materials include normal weight concrete and lightweight concrete. The anchor is designed for consistent and reliable performance in cracked and uncracked concrete.

## Sure-Bolt® Extreme Atlantis Coating

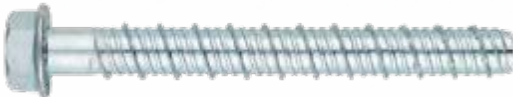

The Sure-Bolt® Extreme is a one-piece heavy-duty Hex Head screw anchor, comprised of a Carbon steel body that is heat treated and then coated for corrosion resistance. It is available in 3/8, 1/2 and 5/8 diameters up to 6" in length. Just drill the same diameter hole as the anchor body and run the part in with either a corded/cordless impact wrench or a regular hand socket. The anchor threads cut into the concrete on the sides of the hole and interlock with the base material during installation. Suitable base materials include normal weight concrete, lightweight concrete, brick, and grout filled block. The anchor has also been evaluated by ICC-ES for consistent use and reliability in Cracked and Uncracked concrete, category 1. The Sure-Bolt® Extreme is an excellent choice for both internal and external applications due to its multiple coating protection. First a layer of zinc is applied to the part, plus two layers of epoxy organic coating to follow. The coating will exceed 700 hours of salt spray before any red rust appears and is suitable for external environments with a service life that exceeds 25 years, making it an excellent choice for external applications. The coating is also resistant to Acids and Alkalis.

## Sleeve Anchor Carbon Steel



Aerosmith®'s Sleeve Anchor is an all-steel pre-assembled anchor that can be used in a variety of solid base materials. Most popular base materials include concrete and masonry. They are available in multiple head styles, such as, hex nut, acorn nut and flat head to give you the finished appearance for your specific application. Simply drill the same diameter hole as the anchor and install anchor through fixture and then tighten to required torque specification.

# HEAVY DUTY MECHANICAL ANCHORS (CONTINUED)

## 304 Stainless Steel Sleeve Anchor



The Aerosmith® 304 Stainless steel sleeve anchor is a preassembled expansion anchor that can be used in a variety of base materials which include, normal weight concrete, brick, and grout filled block. This anchor is available in both 3/8 and 1/2 diameters and comes with either an acorn nut or finished hex nut. Great for both internal and external applications where corrosion may be of concern. Simply drill the same size hole as the anchor diameter using a carbide drill bit and tap the anchor through your fixture and tighten to the required torque value. As you tighten the nut, the bolt pulls through the sleeve creating expansion.

## Drop-ins

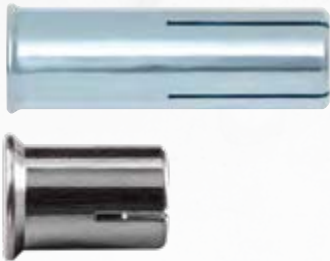

Aerosmith®'s Drop-in is a machine type bolt anchor available in 304 and 316 SS as well as carbon steel. The body is internally threaded for use in flush mount applications and solid base materials. Aerosmith® also offers a coil thread version for concrete forming applications available in both 1/2" and 3/4" diameters. A shallow embedment drop-in is also available which is made from carbon steel and can be used in solid concrete, hollow concrete, plank, hardstone and solid brick. Typical applications include hanging threaded rod overhead. Installation is easy, pre-drill a hole using the proper diameter for the anchor, tap anchor into pre-drilled hole until flush with base material. Use the appropriate setting tool to properly set the anchor and hammer the back of the setting tool until neck is flush with the top of the anchor. Put fixture in place and insert the machine bolt and tighten to the required torque. If using overhead, insert threaded rod to the minimal thread engagement which should be equal to the nominal diameter of the threaded insert. This product can be used in overhead applications.

## Dual Machine Bolt Anchors



Aerosmith®'s Dual Machine Bolt Anchors can be used in solid concrete, brick, block and stone. The Dual Machine Bolt Anchors is made of die cast Zamac alloy and is corrosive resistant. Although the product can be used in many base materials it is sometimes used in questionable materials because it expands against the concrete at two points. Sizes are available from 1/4" to 3/4" diameters. Drill the proper diameter hole to the specified embedment, tap anchor into pre-drilled hole until flush. Put fixture in place and insert machine bolt.

## Machine Bolt Anchors



Aerosmith®'s Machine Bolt Anchors can be used in concrete, block, brick and stone. The anchor consists of a set of expansion shields and an expander cone. The product is manufactured from zinc alloy. As the anchor is tightened, the cone gets drawn into the expansion shield which compresses them against the base material. This product is not recommended in overhead applications.

## Sure-Lag



Aerosmith®'s Sure-Lag can be used to anchor into a variety of base materials such as concrete, brick and grout filled block. Although best suited for light to medium duty fastening, Sure-Lag anchors are available in 1/4", 5/16", 3/8", 1/2", 5/8" diameters, and are available in both short and long versions. The short version is typically used on harder base materials while the longer Sure-Lag are typically used on softer base materials where more embedment is required. Sure-Lags are made from zinc which enables them to be used in many different environmental conditions. To set, drill the proper size hole, tap Sure-Lag into the base material, put fixture in place and thread Lag screw into the lag shield until tight. The fixture is removable because the Sure-Lag anchor remains in the hole and only the lag screw can be unscrewed and removed. Not recommended for overhead applications.

## Caulking Anchor



Aerosmith®'s Caulking Anchor is an internally threaded part whose sleeve is made of Zamac alloy. This anchor comes preassembled and can be used in concrete, brick, block and stone. Pre-drill the proper hole diameter and length, tap anchor into pre-drilled hole and properly set using the proper Aerosmith® caulking setting tool. Once properly set, put fixture in place and use the required machine bolt for proper attachment. This anchor can also be used in normal weight concrete, grout filled concrete, masonry (CMU) brick and stone. This anchor is not recommended for overhead applications.

# Sure-Wedge®



## Suitable for installation in **CRACKED CONCRETE, UNCRACKED CONCRETE, REINFORCED CONCRETE & STONE.**

Aerosmith®'s Sure Wedge® are torque- controlled, mechanical expansion anchors consisting of an anchor body, expansion clip, nut and washer. The anchor body has a tapered mandrel formed on the installed end of the anchor and a threaded section at the opposite end. Suitable base materials include, normal weight concrete and lightweight concrete. The anchors are used to resist static; wind and seismic tension and shear loads in cracked and uncracked normal weight and lightweight concrete having a specific compressive strength of 2500 PSI to 8500 PSI. The anchor is manufactured with a zinc plated carbon steel body and sherardized clip that wraps ESR-4413 around the mandrel, rotating freely before installation.

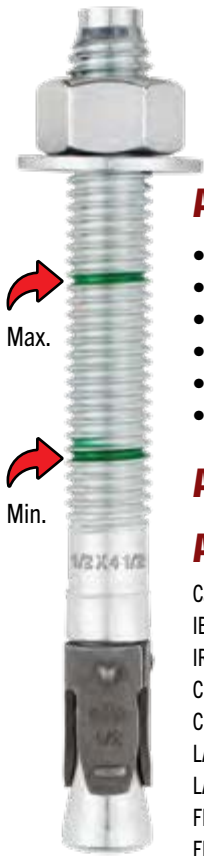

### APPLICATIONS:

- Barriers
- Railings
- Warehouse racking
- Conveyor systems
- Machinery
- Signage
- Fence posts
- Shelving
- Windows
- Overhead doors
- Electrical pipes
- Light fixtures

### FEATURES & BENEFITS:

- Consistent performance in all types of concrete
- Drill size same as anchor size
- Easy and simple installation
- One piece design
- Comes complete with nuts and washers

### BASE MATERIAL:

- Solid concrete
- Grout-filled masonry
- Hard stone

### ANCHOR COMPONENT MATERIALS: Carbon Steel Zinc Plated (body, nut, washer and expansion clip)

### APPROVALS:

Category 1 Cracked & Uncracked Concrete ICC-ES ESR-4413  
 IBC Listed 2021, 2018, 2015, 2012, 2009, 2006  
 IRC Listed 2021, 2018, 2015, 2012, 2009, 2006  
 CBC 2019 Listed  
 CRC 2019 Listed  
 LABC 2020 Listed  
 LARC 2020 Listed  
 FBC 2020 Listed  
 FRC 2020 Listed

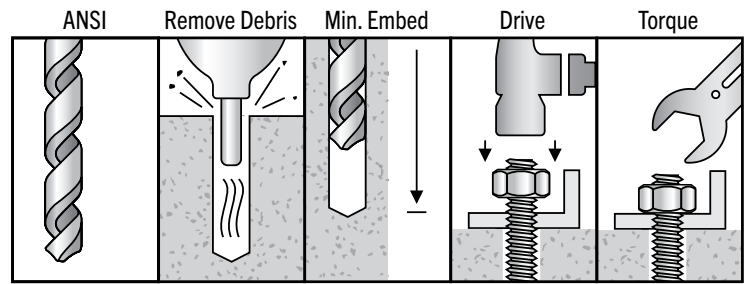

Part ID	Description	Overall Length	Diameter	Drill Diameter	Min. Embed	Max. Torque	Box Quantity	Carton Quantity
WA14134CC	Wedge Anchor Zinc ICC 1/4" X 1-3/4"	1-3/4"	1/4"	1/4"	1-1/2"	4 ft lbs	100	800
WA14214CC	Wedge Anchor Zinc ICC 1/4" X 2-1/4"	2-1/4"	1/4"	1/4"	2"	4 ft lbs	100	800
WA14314CC*	Wedge Anchor Zinc ICC 1/4" X 3 1/4"	3-1/4"	1/4"	1/4"	2"	4 ft lbs	100	800
WA38214CC*	Wedge Anchor Zinc ICC 3/8" X 2-1/4"	2-1/4"	3/8"	3/8"	2-1/3"	30 ft lbs	50	400
WA38234CC*	Wedge Anchor Zinc ICC 3/8" X 2-3/4"	2-3/4"	3/8"	3/8"	2-1/3"	30 ft lbs	50	400
WA38300CC	Wedge Anchor Zinc ICC 3/8" X 3"	3"	3/8"	3/8"	2-1/3"	30 ft lbs	50	200
WA38312CC	Wedge Anchor Zinc ICC 3/8" X 3-1/2"	3-1/2"	3/8"	3/8"	2-1/3"	30 ft lbs	50	200
WA38334CC	Wedge Anchor Zinc ICC 3/8" X 3-3/4"	3-3/4"	3/8"	3/8"	2-1/3"	30 ft lbs	50	200
WA38500CC	Wedge Anchor Zinc ICC 3/8" X 5"	5"	3/8"	3/8"	2-1/3"	30 ft lbs	50	200
WA38700CC	Wedge Anchor Zinc ICC 3/8" X 7"	7"	3/8"	3/8"	2-1/3"	30 ft lbs	50	100
WA12234CC*	Wedge Anchor Zinc ICC 1/2" X 2-3/4"	2-3/4"	1/2"	1/2"	2-1/3"	30 ft lbs	50	200
WA12334CC	Wedge Anchor Zinc ICC 1/2" X 3-3/4"	3-3/4"	1/2"	1/2"	2-1/3"	45 ft lbs	50	200
WA12412CC	Wedge Anchor Zinc ICC 1/2" X 4-1/2"	4-1/2"	1/2"	1/2"	2-1/3"	45 ft lbs	50	100
WA12512CC	Wedge Anchor Zinc ICC 1/2" X 5-1/2"	5-1/2"	1/2"	1/2"	2-1/3"	45 ft lbs	25	100
WA12700CC	Wedge Anchor Zinc ICC 1/2" X 7"	7"	1/2"	1/2"	2-1/3"	45 ft lbs	25	100
WA12100CC	Wedge Anchor Zinc ICC 1/2" X 10"	10"	1/2"	1/2"	2-1/3"	45 ft lbs	25	50
WA58312CC*	Wedge Anchor Zinc ICC 5/8" X 3-1/2"	3-1/2"	5/8"	5/8"	3-1/4"	75 ft lbs	20	80
WA58412CC	Wedge Anchor Zinc ICC 5/8" X 4-1/2"	4-1/2"	5/8"	5/8"	3-1/4"	75 ft lbs	20	80
WA58500CC	Wedge Anchor Zinc ICC 5/8" X 5"	5"	5/8"	5/8"	3-1/4"	75 ft lbs	20	80
WA58600CC	Wedge Anchor Zinc ICC 5/8" X 6"	6"	5/8"	5/8"	3-1/4"	75 ft lbs	20	40
WA58700CC	Wedge Anchor Zinc ICC 5/8" X 7"	7"	5/8"	5/8"	3-1/4"	75 ft lbs	20	40
WA58812CC	Wedge Anchor Zinc ICC 5/8" X 8-1/2"	8-1/2"	5/8"	5/8"	3-1/4"	75 ft lbs	20	40
WA34414CC*	Wedge Anchor Zinc ICC 3/4" X 4-1/4"	4-1/4"	3/4"	3/4"	3-3/4"	150 ft lbs	10	40
WA34434CC*	Wedge Anchor Zinc ICC 3/4" X 4-3/4"	4-3/4"	3/4"	3/4"	3-3/4"	150 ft lbs	10	40
WA34512CC	Wedge Anchor Zinc ICC 3/4" X 5-1/2"	5-1/2"	3/4"	3/4"	3-3/4"	150 ft lbs	10	40
WA34614CC	Wedge Anchor Zinc ICC 3/4" X 6-1/4"	6-1/4"	3/4"	3/4"	3-3/4"	150 ft lbs	10	40
WA34700CC	Wedge Anchor Zinc ICC 3/4" x 7"	7"	3/4"	3/4"	3-3/4"	150 ft lbs	10	40
WA34812CC	Wedge Anchor Zinc ICC 3/4" X 8-1/2"	8-1/2"	3/4"	3/4"	3-3/4"	150 ft lbs	10	20
WA34100CC	Wedge Anchor Zinc ICC 3/4" X 10"	10"	3/4"	3/4"	3-3/4"	150 ft lbs	10	20

\*This size is less than the required minimum standard anchor length for strength design

Identification Code



# Carbon Steel Wedge Anchors

Aerosmith®'s Wedge Anchor is designed for consistent performance in solid concrete or grout filled concrete masonry. The anchor is threaded and comes complete with a nut and washer. The body is made of carbon steel with an expansion clip. Anchor is driven into a pre-drilled hole which is the same diameter as the anchor body. The anchor is set by tightening the nut to the required torque value for optimum performance. To help identify the length of an installed anchor an identification code can be seen visually at the top of the anchor to determine length after the anchor has been installed.

## APPLICATIONS:

- Barriers
- Railings
- Warehouse racking
- Conveyor systems
- Machinery
- Signage
- Fence posts
- Shelving
- Windows
- Overhead doors
- Electrical pipes
- Light fixtures

## FEATURES & BENEFITS:

- Consistent performance in all types of concrete
- Drill size same as anchor size
- Easy and simple installation
- One piece design
- Comes complete with nuts and washers

## BASE MATERIAL:

- Solid concrete
- Grout-filled masonry
- Hard stone

## ANCHOR COMPONENT MATERIALS:

Carbon Steel Zinc Plated  
(body, nut, washer and expansion clip)

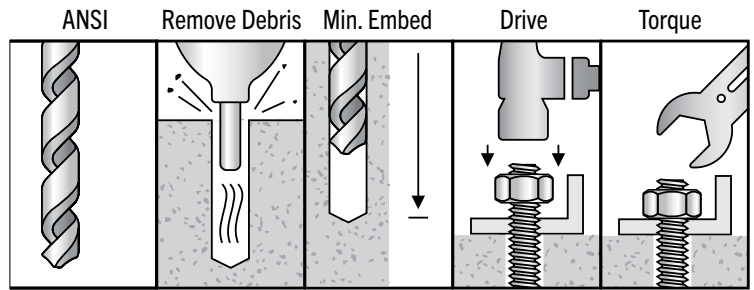

Part ID	Description	Overall Length	Diameter	ANSI Drill Diameter	Min. Embed	Max. Torque	Box Quantity	Carton Quantity
WAG14134	Wedge Anchor Zinc 1/4" X 1-3/4"	1-3/4"	1/4"	1/4"	1-1/8"	4 ft lbs	100	600
WAG14214	Wedge Anchor Zinc 1/4" X 2-1/4"	2-1/4"	1/4"	1/4"	1-1/8"	4 ft lbs	100	600
WAG14314	Wedge Anchor Zinc 1/4" X 3-1/4"	3-1/4"	1/4"	1/4"	1-1/8"	4 ft lbs	100	600
WAG38214	Wedge Anchor Zinc 3/8" X 2-1/4"	2-1/4"	3/8"	3/8"	1 5/8"	20 ft lbs	50	300
WAG38234	Wedge Anchor Zinc 3/8" X 2-3/4"	2-3/4"	3/8"	3/8"	1-5/8"	20 ft lbs	50	300
WAG38300	Wedge Anchor Zinc 3/8" X 3"	3"	3/8"	3/8"	1-5/8"	20 ft lbs	50	300
WAG38312	Wedge Anchor Zinc 3/8" X 3-1/2"	3-1/2"	3/8"	3/8"	1-5/8"	20 ft lbs	50	300
WAG38334	Wedge Anchor Zinc 3/8" X 3-3/4"	3-3/4"	3/8"	3/8"	1-5/8"	20 ft lbs	50	300
WAG38500	Wedge Anchor Zinc 3/8" X 5"	5"	3/8"	3/8"	1-5/8"	20 ft lbs	50	300
WAG38700	Wedge Anchor Zinc 3/8" X 7"	7"	3/8"	3/8"	1-5/8"	20 ft lbs	50	200
WAG12234	Wedge Anchor Zinc 1/2" X 2-3/4"	2-3/4"	1/2"	1/2"	2-1/4"	40 ft lbs	50	200
WAG12334	Wedge Anchor Zinc 1/2" X 3-3/4"	3-3/4"	1/2"	1/2"	2-1/4"	40 ft lbs	50	200
WAG12412	Wedge Anchor Zinc 1/2" X 4-1/2"	4-1/2"	1/2"	1/2"	2-1/4"	40 ft lbs	50	200
WAG12512	Wedge Anchor Zinc 1/2" X 5-1/2"	5-1/2"	1/2"	1/2"	2-1/4"	40 ft lbs	50	150
WAG12700	Wedge Anchor Zinc 1/2" X 7"	7"	1/2"	1/2"	2-1/4"	40 ft lbs	25	100
WAG12812	Wedge Anchor Zinc 1/2" X 8-1/2"	8-1/2"	1/2"	1/2"	2-1/4"	40 ft lbs	25	100
WAG58312	Wedge Anchor Zinc 5/8" X 3-1/2"	3-1/2"	5/8"	5/8"	2-3/4"	80 ft lbs	25	100
WAG58412	Wedge Anchor Zinc 5/8" X 4-1/2"	4-1/2"	5/8"	5/8"	2-3/4"	80 ft lbs	25	100
WAG58500	Wedge Anchor Zinc 5/8" X 5"	5"	5/8"	5/8"	2-3/4"	80 ft lbs	25	100
WAG58600	Wedge Anchor Zinc 5/8" X 6"	6"	5/8"	5/8"	2-3/4"	80 ft lbs	25	75
WAG58700	Wedge Anchor Zinc 5/8" X 7"	7"	5/8"	5/8"	2-3/4"	80 ft lbs	25	75
WAG58812	Wedge Anchor Zinc 5/8" X 8-1/2"	8-1/2"	5/8"	5/8"	2-3/4"	80 ft lbs	25	50
WAG34414	Wedge Anchor Zinc 3/4" X 4-1/4"	4-1/4"	3/4"	3/4"	3-3/8"	110 ft lbs	20	60
WAG34434	Wedge Anchor Zinc 3/4" X 4-3/4"	4-3/4"	3/4"	3/4"	3-3/8"	110 ft lbs	20	60
WAG34512	Wedge Anchor Zinc 3/4" X 5-1/2"	5-1/2"	3/4"	3/4"	3-3/8"	110 ft lbs	20	60
WAG34614	Wedge Anchor Zinc 3/4" X 6-1/4"	6-1/4"	3/4"	3/4"	3-3/8"	110 ft lbs	20	60
WAG34700	Wedge Anchor Zinc 3/4" X 7"	7"	3/4"	3/4"	3-3/8"	110 ft lbs	20	60
WAG34812	Wedge Anchor Zinc 3/4" X 8-1/2"	8-1/2"	3/4"	3/4"	3-3/8"	110 ft lbs	10	40
WAG34100	Wedge Anchor Zinc 3/4" X 10"	10"	3/4"	3/4"	3-3/8"	110 ft lbs	10	40
WAG16000	Wedge Anchor Zinc 1" X 6"	6"	1"	1"	4-1/2"	300 ft lbs	10	30
WAG16900	Wedge Anchor Zinc 1" X 9"	9"	1"	1"	4-1/2"	300 ft lbs	10	20
WAG11200	Wedge Anchor Zinc 1" X 12"	12"	1"	1"	4-1/2"	300 ft lbs	5	10



Identification Code



# Wedge Anchor Type 304 Stainless Steel

Aerosmith®'s Wedge Anchor Type 304 Stainless Steel is designed for consistent performance in solid concrete or grout filled concrete masonry. The anchor is threaded and comes complete with a nut and washer which are made of 304 Stainless Steel. The body is made of 304 Stainless Steel with a 304 Stainless Steel expansion clip. Anchor is driven into a pre-drilled hole which is the same diameter as the anchor body. The anchor is set by tightening the nut to the required torque value for optimum performance. To help identify the length of an installed anchor an identification code can be seen visually at the top of the anchor to determine length after the anchor has been installed. The material type enables you to use this product in both internal and some external applications where corrosion resistance may be required. **To determine which product to use in external applications please consult an engineer.**

## APPLICATIONS:

- Barriers
- Railings
- Warehouse racking
- Conveyor systems
- Machinery
- Signage
- Fence posts
- Shelving
- Windows
- Overhead doors
- Electrical pipes
- Light fixtures

## FEATURES & BENEFITS:

- Consistent performance in all types of concrete
- Drill size same as anchor size
- Easy and simple installation
- One piece design
- Comes complete with nuts and washers

## BASE MATERIAL:

- Solid concrete
- Grout-filled masonry
- Hard stone

## ANCHOR COMPONENT MATERIALS:

304 Stainless Steel  
(body, nut, washer and expansion clip)

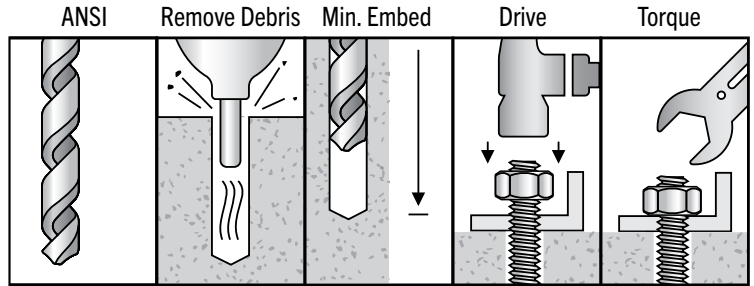

Part ID	Description	Overall Length	Diameter	ANSI Drill Diameter	Min. Embed	Max. Torque	Box Quantity	Carton Quantity
WA4SS14134	Wedge Anchor 304SS 1/4" X 1-3/4"	1-3/4"	1/4"	1/4"	1-1/8"	6 ft lbs	100	600
WA4SS14214	Wedge Anchor 304SS 1/4" X 2-1/4"	2-1/4"	1/4"	1/4"	1-1/8"	6 ft lbs	100	600
WA4SS14314	Wedge Anchor 304SS 1/4" X 3-1/4"	3-1/4"	1/4"	1/4"	1-1/8"	6 ft lbs	100	600
WA4SS38214	Wedge Anchor 304SS 3/8" X 2-1/4"	2-1/4"	3/8"	3/8"	1-3/8"	25 ft lbs	50	300
WA4SS38234	Wedge Anchor 304SS 3/8" X 2-3/4"	2-3/4"	3/8"	3/8"	1-3/8"	25 ft lbs	50	300
WA4SS38300	Wedge Anchor 304SS 3/8" X 3"	3"	3/8"	3/8"	1-3/8"	25 ft lbs	50	300
WA4SS38312	Wedge Anchor 304SS 3/8" X 3-1/2"	3-1/2"	3/8"	3/8"	1-3/8"	25 ft lbs	50	300
WA4SS38334	Wedge Anchor 304SS 3/8" X 3-3/4"	3-3/4"	3/8"	3/8"	1-3/8"	25 ft lbs	50	300
WA4SS38500	Wedge Anchor 304SS 3/8" X 5"	5"	3/8"	3/8"	1-3/8"	25 ft lbs	50	300
WA4SS12234	Wedge Anchor 304SS 1/2" X 2-3/4"	2-3/4"	1/2"	1/2"	1-7/8"	40 ft lbs	50	200
WA4SS12334	Wedge Anchor 304SS 1/2" X 3-3/4"	3-3/4"	1/2"	1/2"	1-7/8"	40 ft lbs	50	200
WA4SS12412	Wedge Anchor 304SS 1/2" X 4-1/2"	4-1/2"	1/2"	1/2"	1-7/8"	40 ft lbs	50	200
WA4SS12512	Wedge Anchor 304SS 1/2" X 5-1/2"	5-1/2"	1/2"	1/2"	1-7/8"	40 ft lbs	50	150
WA4SS12700	Wedge Anchor 304SS 1/2" X 7"	7"	1/2"	1/2"	1-7/8"	40 ft lbs	25	100
WA4SS58312	Wedge Anchor 304SS 5/8" X 3-1/2"	3-1/2"	5/8"	5/8"	2-1/2"	60 ft lbs	25	100
WA4SS58412	Wedge Anchor 304SS 5/8" X 4-1/2"	4-1/2"	5/8"	5/8"	2-1/2"	60 ft lbs	25	100
WA4SS58500	Wedge Anchor 304SS 5/8" X 5"	5"	5/8"	5/8"	2-1/2"	60 ft lbs	25	100
WA4SS58600	Wedge Anchor 304SS 5/8" X 6"	6"	5/8"	5/8"	2-1/2"	60 ft lbs	25	75
WA4SS58700	Wedge Anchor 304SS 5/8" X 7"	7"	5/8"	5/8"	2-1/2"	60 ft lbs	25	75
WA4SS58812	Wedge Anchor 304SS 5/8" X 8-1/2"	8-1/2"	5/8"	5/8"	2-1/2"	60 ft lbs	25	50
WA4SS34414	Wedge Anchor 304SS 3/4" X 4-1/4"	4-1/2"	3/4"	3/4"	3-3/8"	110 ft lbs	20	60
WA4SS34434	Wedge Anchor 304SS 3/4" X 4-3/4"	4-3/4"	3/4"	3/4"	3-3/8"	110 ft lbs	20	60
WA4SS34512	Wedge Anchor 304SS 3/4" X 5-1/2"	5-1/2"	3/4"	3/4"	3-3/8"	110 ft lbs	20	60
WA4SS34614	Wedge Anchor 304SS 3/4" X 6-1/4"	6-1/4"	3/4"	3/4"	3-3/8"	110 ft lbs	20	60
WA4SS34700	Wedge Anchor 304SS 3/4" X 7"	7"	3/4"	3/4"	3-3/8"	110 ft lbs	20	60
WA4SS34812	Wedge Anchor 304SS 3/4" X 8-1/2"	8-1/2"	3/4"	3/4"	3-3/8"	110 ft lbs	10	40
WA4SS34100	Wedge Anchor 304SS 3/4" X 10"	10"	3/4"	3/4"	3-3/8"	110 ft lbs	10	40
WA4SS16000	Wedge Anchor 304SS 1" X 6"	6"	1"	1"	4-1/2"	300 ft lbs	10	30
WA4SS19000	Wedge Anchor 304SS 1" X 9"	9"	1"	1"	4-1/2"	300 ft lbs	10	20
WA4SS11200	Wedge Anchor 304SS 1" X 12"	12"	1"	1"	4-1/2"	300 ft lbs	5	10

Identification Code



# Wedge Anchor Type 316 Stainless Steel

Aerosmith®'s Wedge Anchor Type 316 Stainless Steel is designed for consistent performance in solid concrete or grout filled concrete masonry. The anchor is threaded and comes complete with a nut and washer which are made of 316 Stainless Steel. The body is made of 316 Stainless Steel with a 316 Stainless Steel expansion clip. Anchor is driven into a pre-drilled hole which is the same diameter as the anchor body. The anchor is set by tightening the nut to the required torque value for optimum performance. To help identify the length of an installed anchor an identification code can be seen visually at the top of the anchor to determine length after the anchor has been installed. The material grade enables you to use this product in both internal and some external applications where corrosion resistance may be required. **To determine which product to use in external applications please consult an engineer.**

## APPLICATIONS:

- Barriers
- Railings
- Warehouse racking
- Conveyor systems
- Machinery
- Signage
- Fence posts
- Shelving
- Windows
- Overhead doors
- Electrical pipes
- Light fixtures

## FEATURES & BENEFITS:

- Consistent performance in all types of concrete
- Drill size same as anchor size
- Easy and simple installation
- One piece design
- Comes complete with nuts and washers

## BASE MATERIAL:

- Solid concrete
- Grout-filled masonry
- Hard stone

## ANCHOR COMPONENT MATERIALS:

316 Stainless Steel  
(body, nut, washer and expansion clip)

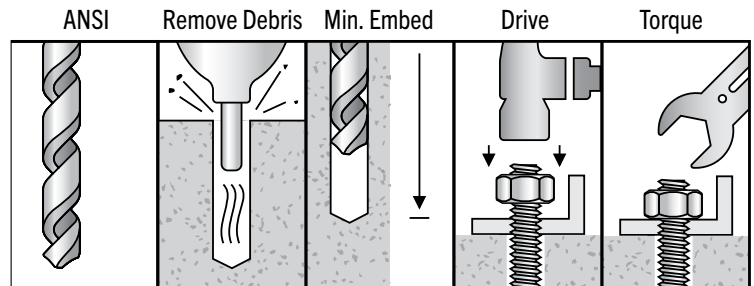

Part ID	Description	Overall Length	Diameter	ANSI Drill Diameter	Min. Embed	Max. Torque	Box Quantity	Carton Quantity
WA6SS14134	Wedge Anchor 316SS 1/4" X 1-3/4"	1-3/4"	1/4"	1/4"	1-1/8"	6 ft lbs	100	600
WA6SS14214	Wedge Anchor 316SS 1/4" X 2-1/4"	2-1/4"	1/4"	1/4"	1-1/8"	6 ft lbs	100	600
WA6SS14314	Wedge Anchor 316SS 1/4" X 3-1/4"	3-1/4"	1/4"	1/4"	1-1/8"	6 ft lbs	100	600
WA6SS38214	Wedge Anchor 316SS 3/8" X 2-1/4"	2-1/4"	3/8"	3/8"	1-3/8"	25 ft lbs	50	300
WA6SS38234	Wedge Anchor 316SS 3/8" X 2-3/4"	2-3/4"	3/8"	3/8"	1-3/8"	25 ft lbs	50	300
WA6SS38300	Wedge Anchor 316SS 3/8" X 3"	3"	3/8"	3/8"	1-3/8"	25 ft lbs	50	300
WA6SS38312	Wedge Anchor 316SS 3/8" X 3-1/2"	3-1/2"	3/8"	3/8"	1-3/8"	25 ft lbs	50	300
WA6SS38334	Wedge Anchor 316SS 3/8" X 3-3/4"	3-3/4"	3/8"	3/8"	1-3/8"	25 ft lbs	50	300
WA6SS38500	Wedge Anchor 316SS 3/8" X 5"	5"	3/8"	3/8"	1-3/8"	25 ft lbs	50	300
WA6SS12234	Wedge Anchor 316SS 1/2" X 2-3/4"	2-3/4"	1/2"	1/2"	1-7/8"	40 ft lbs	50	200
WA6SS12334	Wedge Anchor 316SS 1/2" X 3-3/4"	3-3/4"	1/2"	1/2"	1-7/8"	40 ft lbs	50	200
WA6SS12412	Wedge Anchor 316SS 1/2" X 4-1/2"	4-1/2"	1/2"	1/2"	1-7/8"	40 ft lbs	50	200
WA6SS12512	Wedge Anchor 316SS 1/2" X 5-1/2"	5-1/2"	1/2"	1/2"	1-7/8"	40 ft lbs	50	150
WA6SS12700	Wedge Anchor 316SS 1/2" X 7"	7"	1/2"	1/2"	1-7/8"	40 ft lbs	25	100
WA6SS58312	Wedge Anchor 316SS 5/8" X 3-1/2"	3-1/2"	5/8"	5/8"	2-1/2"	60 ft lbs	25	100
WA6SS58412	Wedge Anchor 316SS 5/8" X 4-1/2"	4-1/2"	5/8"	5/8"	2-1/2"	60 ft lbs	25	100
WA6SS58500	Wedge Anchor 316SS 5/8" X 5"	5"	5/8"	5/8"	2-1/2"	60 ft lbs	25	100
WA6SS58600	Wedge Anchor 316SS 5/8" X 6"	6"	5/8"	5/8"	2-1/2"	60 ft lbs	25	75
WA6SS58700	Wedge Anchor 316SS 5/8" X 7"	7"	5/8"	5/8"	2-1/2"	60 ft lbs	25	75
WA6SS58812	Wedge Anchor 316SS 5/8" X 8-1/2"	8-1/2"	5/8"	5/8"	2-1/2"	60 ft lbs	25	50
WA6SS34414	Wedge Anchor 316SS 3/4" X 4-1/4"	4-1/4"	3/4"	3/4"	3-3/8"	110 ft lbs	20	60
WA6SS34434	Wedge Anchor 316SS 3/4" X 4-3/4"	4-3/4"	3/4"	3/4"	3-3/8"	110 ft lbs	20	60
WA6SS34512	Wedge Anchor 316SS 3/4" X 5-1/2"	5-1/2"	3/4"	3/4"	3-3/8"	110 ft lbs	20	60
WA6SS34614	Wedge Anchor 316SS 3/4" X 6-1/4"	6-1/4"	3/4"	3/4"	3-3/8"	110 ft lbs	20	60
WA6SS34700	Wedge Anchor 316SS 3/4" X 7"	7"	3/4"	3/4"	3-3/8"	110 ft lbs	20	60
WA6SS34812	Wedge Anchor 316SS 3/4" X 8-1/2"	8-1/2"	3/4"	3/4"	3-3/8"	110 ft lbs	10	40



# Sure-Bolt®

## Suitable for installation in CRACKED CONCRETE, UNCRACKED CONCRETE, REINFORCED CONCRETE & STONE.

The Aerosmith® Sure Bolt® is a one-piece, heavy duty screw anchor with a finished hex head. The anchor is manufactured from carbon steel and is heat treated. The Sure-Bolt™ is available in a variety of sizes from 1/4 to 3/4 inch. The hex head diameter is larger than the diameter of the anchor and is formed with serrations on the underside. The anchor can be installed in a pre-drilled hole with a powered impact wrench or a torque wrench. The anchor threads cut into concrete on the sides of the hole and interlock with the base material during the installation. Once installed they are easily identifiable by head markings with ASF on the head. Suitable base materials include normal weight concrete, and lightweight concrete. The anchor is designed for consistent and reliable performance in cracked and uncracked concrete.

### APPLICATIONS:

- Structural anchoring in cracked and uncracked concrete, including industrial environments
- Glazing, windows and shop windows
- Industrial racking and conveyor systems
- Installation of railings and handrails in interiors applications
- Anchoring of machinery, boilers, signs, stadium seating, facade substructures, etc.
- Anchoring through wood into concrete base materials
- Removable

### FEATURES & BENEFITS:

- Quick and easy installation
- Use in cracked and uncracked concrete
- Use for medium-heavy duty loads.
- Finished hex head
- Removable
- One piece assembly
- Variety of length and diameters
- Suitable when reduced distance to edge and between anchors is required
- Mechanical interlock between concrete and thread
- For static and quasi static loads
- Can be un-installed leaving the surface clear with no obstructions

### APPROVALS:

Category 1 Cracked & Uncracked Concrete  
 ICC-ES ESR-4413  
 IBC Listed 2021, 2018, 2015, 2012, 2009, 2006  
 IRC Listed 2021, 2018, 2015, 2012, 2009, 2006  
 CBC 2019 Listed  
 CRC 2019 Listed  
 LABC 2020 Listed  
 LARC 2020 Listed  
 FBC 2020 Listed  
 FRC 2020 Listed



### BASE MATERIAL:

- Normal weight and lightweight concrete
- Reinforced concrete
- Cracked and uncracked concrete

### ANCHOR COMPONENT MATERIALS:

Carbon Steel Body, Zinc Plated, with a hex washer head

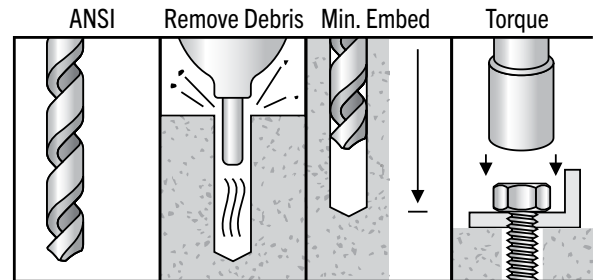

Part ID	Description	Overall Length	Diameter	ANSI Drill Diameter	Min. Embed	Max. Torque	Box Quantity	Carton Quantity
CB14114CC*	1/4" x 1-1/4"	1-1/4"	1/4"	1/4"	1"	24 ft lbs	100	800
CB14134CC*	1/4" x 1-3/4"	1-3/4"	1/4"	1/4"	1-1/2"	24 ft lbs	100	800
CB14214CC*	1/4" x 2-1/4"	2-1/4"	1/4"	1/4"	1-5/8"	24 ft lbs	100	600
CB14300CC*	1/4" x 3"	3"	1/4"	1/4"	1-5/8"	24 ft lbs	50	400
CB38134CC*	3/8" x 1-3/4"	1-3/4"	3/8"	3/8"	1-1/2"	35 ft lbs	50	200
CB38212CC	3/8" x 2-1/2"	2-1/2"	3/8"	3/8"	2-1/4"	35 ft lbs	50	200
CB38300CC	3/8" x 3"	3"	3/8"	3/8"	2-1/2"	35 ft lbs	50	200
CB38400CC	3/8" x 4"	4"	3/8"	3/8"	2-1/2"	35 ft lbs	50	200
CB38500CC	3/8" x 5"	5"	3/8"	3/8"	2-1/2"	35 ft lbs	50	200
CB38600CC	3/8" x 6"	6"	3/8"	3/8"	2-1/2"	35 ft lbs	50	200
CB12200CC*	1/2" x 2"	2"	1/2"	1/2"	1-3/4"	35 ft lbs	50	100
CB12212CC*	1/2" x 2-1/2"	2-1/2"	1/2"	1/2"	2-1/4"	45 ft lbs	50	100
CB12300CC	1/2" x 3"	3"	1/2"	1/2"	2-3/4"	45 ft lbs	50	100
CB12400CC	1/2" x 4"	4"	1/2"	1/2"	3"	45 ft lbs	50	100
CB12500CC	1/2" x 5"	5"	1/2"	1/2"	3"	45 ft lbs	25	50
CB12600CC	1/2" x 6"	6"	1/2"	1/2"	3"	45 ft lbs	25	50
CB12800CC	1/2" x 8"	8"	1/2"	1/2"	3"	45 ft lbs	20	80
CB58300CC*	5/8" x 3"	3"	5/8"	5/8"	2-3/4"	85 ft lbs	25	50
CB58400CC	5/8" x 4"	4"	5/8"	5/8"	3-1/4"	85 ft lbs	25	50
CB58500CC	5/8" x 5"	5"	5/8"	5/8"	3-1/4"	85 ft lbs	25	50
CB58600CC	5/8" x 6"	6"	5/8"	5/8"	3-1/4"	85 ft lbs	20	40
CB58800CC	5/8" x 8"	8"	5/8"	5/8"	3-1/4"	85 ft lb	20	40
CB34400CC	3/4" x 4"	4"	3/4"	3/4"	3-3/4"	115 ft lbs	20	40
CB34500CC	3/4" x 5"	5"	3/4"	3/4"	4"	115 ft lbs	20	40
CB34600CC	3/4" x 6"	6"	3/4"	3/4"	4"	115 ft lbs	10	20
CB34800CC	3/4" x 8"	8"	3/4"	3/4"	4"	115 ft lbs	10	20
CB34100CC	3/4" x 10"	10"	3/4"	3/4"	4"	115 ft lbs	10	20

\*This size is less than the required minimum standard anchor length for strength design



# Sure-Bolt® Extreme (Atlantis Coating)

**Suitable for installation in CRACKED CONCRETE, UNCRACKED CONCRETE, REINFORCED CONCRETE & STONE.**

The Sure-Bolt® Extreme is a one-piece heavy-duty Hex Head screw anchor, comprised of a Carbon steel body that is heat treated and then coated for corrosion resistance. It is available in 3/8, 1/2 and 5/8 diameters up to 6" in length. Just drill the same diameter hole as the anchor body and run the part in with either a corded/cordless impact wrench or a regular hand socket. The anchor threads cut into the concrete on the sides of the hole and interlock with the base material during installation. Suitable base materials include normal weight concrete, lightweight concrete, brick, and grout filled block. The anchor has also been evaluated by ICC-ES for consistent use and reliability in Cracked and Uncracked concrete, category 1.

The Sure-Bolt® Extreme is an excellent choice for both internal and external applications due to its multiple coating protection. First a layer of zinc is applied to the part, plus two layers of epoxy organic coating to follow. The coating will exceed 700 hours of salt spray before any red rust appears and is suitable for external environments with a service life that exceeds 25 years, making it an excellent choice for external applications. The coating is also resistant to Acids and Alkalis.

## APPLICATIONS:

- Structural anchoring in cracked and uncracked concrete, including industrial environments
- Glazing, windows and shop windows
- Industrial racking and conveyor systems
- Installation of railings and handrails in interiors applications
- Anchoring of machinery, boilers, signs, stadium seating, facade substructures, etc.
- Anchoring through wood into concrete base materials
- Removable

## BASE MATERIAL:

- Normal weight and lightweight concrete
- Reinforced concrete
- Cracked and uncracked concrete

## FEATURES & BENEFITS:

- Quick and easy installation
- Use in cracked and uncracked concrete
- Use for medium-heavy duty loads.
- Finished hex head
- Removable
- One piece assembly
- Variety of length and diameters
- Suitable when reduced distance to edge and between anchors is required
- Mechanical interlock between concrete and thread
- For static and quasi static loads
- Can be un-installed leaving the surface clear with no obstructions

## APPROVALS:

Category 1 Cracked & Uncracked Concrete I  
CC-ES ESR-4414  
IBC Listed 2009, 2012, 2015, 2018  
IRC Listed 2009, 2012, 2015,  
2018 CBC 2016 Listed CRC 2016 Listed LABC  
2017 Listed LARC 2017 Listed  
FBC 2017 Listed  
FRC 2017 Listed

**FOR INSTALLATION  
INSTRUCTIONS SEE  
PAGE 43.**

## ANCHOR COMPONENT MATERIALS:

Carbon Steel Body, Zinc Plated, with a hex washer head with additional coating

Part ID	Product Name	Description	Overall Length	Diameter	ANSI Drill Diameter	Min. Embed	Max. Torque	Box Quantity	Carton Quantity
CB38300CCA	Atlantis Coating	3/8" x 3"	3"	3/8"	3/8"	2-1/2"	35 ft. lbs	50	200
CB38400CCA	Atlantis Coating	3/8" x 4"	4"	3/8"	3/8"	2-1/2"	35 ft. lbs	50	200
CB38500CCA	Atlantis Coating	3/8" x 5"	5"	3/8"	3/8"	2-1/2"	35 ft. lbs	50	200
CB12400CCA	Atlantis Coating	1/2" x 4"	4"	1/2"	1/2"	3"	45 ft. lbs	50	100
CB12500CCA	Atlantis Coating	1/2" x 5"	5"	1/2"	1/2"	3"	35 ft. lbs	50	50
CB12600CCA	Atlantis Coating	1/2" x 6"	6"	1/2"	1/2"	3"	45 ft. lbs	50	50
CB58600CCA	Atlantis Coating	5/8" x 6"	6"	5/8"	5/8"	3-1/4"	85 ft. lbs	50	50



# 304 Stainless Steel Sleeve Anchor

The Aerosmith® 304 Stainless steel sleeve anchor is a preassembled expansion anchor that can be used in a variety of base materials which include normal weight concrete, brick, and grout filled block. This anchor is available in both 3/8 and 1/2 diameters and comes with either an acorn nut or finished hex nut. Great for both internal and external applications where corrosion may be of concern. Simply drill the same size hole as the anchor diameter using a carbide drill bit and tap the anchor through your fixture and tighten to the required torque value. As you tighten the nut, the bolt pulls through the sleeve creating expansion.

Part ID	Description	Overall Length	Overall Diameter	ANSI Drill Diameter	ANSI Drill Diameter	Max Fixture Thickness	Box Quantity	Carton Quantity
SAH4SS381780	3/8" x 1 7/8" (Hex Head)	1-7/8"	3/8"	3/8"	2-1/2"	1-1/4"	50	400
SAH4SS383000	3/8" x 3" (Hex Head)	3"	3/8"	3/8"	2-1/2"	1-1/4"	50	250
SAH4SS122120	1/2" x 2-1/2" (Hex Head)	2-1/2"	1/2"	1/2"	2-1/2"	1-1/2"	25	150
SAH4SS123000	1/2" x 3" (Hex Head)	3"	1/2"	1/2"	3"	1-1/2"	25	150
SAH4SS123340	1/2" X 3-3/4" (Hex Head)	3-3/4"	1/2"	1/2"	3"	1-1/2"	25	150
<b>Sleeve Anchors 304 Stainless Steel Acorn Head</b>								
SAA4SS141380	1/4" x 1-3/8" Acorn Head)	1-3/8"	1/4"	1/4"	3-1/4"	1/2"	100	800

## FEATURES & BENEFITS:

- Variety of head styles
- Can be used in a variety of base materials
- Pre-assembled anchor for quick installation
- Anchor size is the same as hole size.

## BASE MATERIAL:

- Normal weight and lightweight concrete
- Reinforced concrete

## ANCHOR COMPONENT MATERIALS:

- 304 Stainless Steel body
- with 304 Stainless Steel Washer & Nut additional coating

**FOR INSTALLATION INSTRUCTIONS SEE PAGE 45.**



# Sleeve Anchor Carbon Steel

Aerosmith®'s Sleeve Anchor is an all-steel pre-assembled anchor that can be used in a variety of solid base materials. Most popular base materials include concrete and masonry. They are available in multiple head styles, such as, hex nut, acorn nut and flat head to give you the finished appearance for your specific application. Simply drill the same diameter hole as the anchor and install anchor through fixture and then tighten to required torque. Sleeve Anchor is an all-steel pre-assembled anchor that can be used in a variety of solid base materials. Most popular base materials include concrete and masonry.

## APPLICATIONS:

- Light to medium duty signage
- Electrical boxes
- Shelving
- Junction boxes
- Door frames
- Window frames

## FEATURES & BENEFITS:

- Variety of head styles
- Can be used in a variety of base materials
- All steel component design
- Pre-assembled anchor for quick installation
- Anchor size is the same as hole size.

## BASE MATERIAL:

- Concrete
- Grout filled masonry
- Block (expansion must be in solid portion)
- Brick
- Stone

## ANCHOR COMPONENT MATERIALS:

Carbon Steel Zinc Plated  
(body, nut & washer, expansion sleeve Carbon Steel)

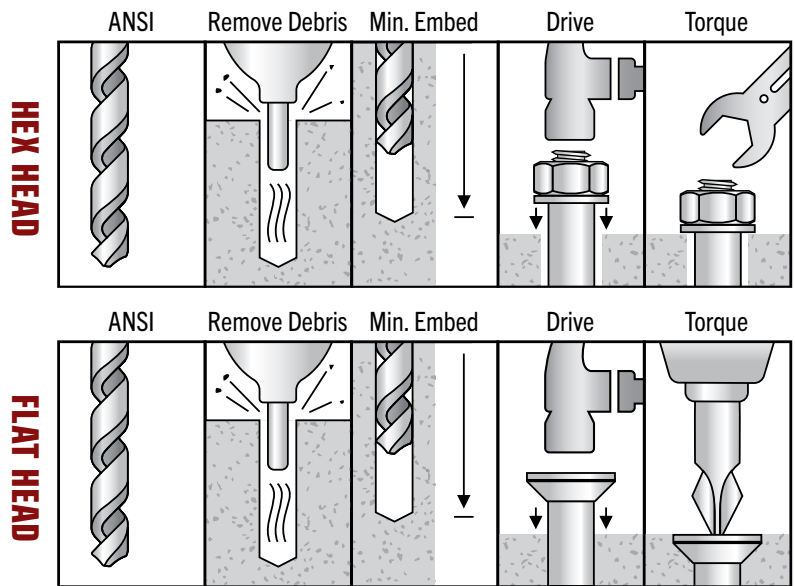

Part ID	Description	Usable Length	Diameter	ANSI Drill Diameter	Max. Fixture Thickness	Max. Torque	Box Quantity	Carton Quantity
SAH516112	5/16" X 1-1/2"	1-1/2"	5/16"	5/16"	1"	12 ft lbs	100	600
SAH516212	5/16" X 2-1/2"	2-1/2"	5/16"	5/16"	1"	12 ft lbs	100	500
SAH381780	3/8" X 1-7/8"	1-7/8"	3/8"	3/8"	1-1/4"	12 ft lbs	50	400
SAH383000	3/8" X 3"	3"	3/8"	3/8"	1-1/4"	18 ft lbs	50	250
SAH384000	3/8" X 4"	4"	3/8"	3/8"	1-1/4"	18 ft lbs	50	250
SAH122120	1/2" X 2-1/2"	2-1/2"	1/2"	1/2"	1-1/2"	18 ft lbs	25	150
SAH582140	5/8" X 2-1/4"	2-1/4"	5/8"	5/8"	2"	50 ft lbs	25	125
SAH123000	1/2" X 3"	3"	1/2"	1/2"	1-1/2"	26 ft lbs	25	150
SAH126000	1/2" X 6"	6"	1/2"	1/2"	1-1/2"	26 ft lbs	10	50
SAH583000	5/8" X 3"	3"	5/8"	5/8"	2"	26 ft lbs	25	125
SAH584140	5/8" X 4-1/4"	4-1/4"	5/8"	5/8"	2"	50 ft lbs	10	80
SAH585340	5/8" X 5-3/4"	5-3/4"	5/8"	5/8"	2"	50 ft lbs	10	50
SAH342140	3/4" X 2-1/2"	2-1/2"	3/4"	3/4"	2-1/4"	90 ft lbs	10	80
SAH344140	3/4" X 4-1/4"	4-1/4"	3/4"	3/4"	2-1/4"	50 ft lbs	10	40
SAH346140	3/4" X 6-1/4"	6-1/4"	3/4"	3/4"	2-1/4"	90 ft lbs	10	30
SAH348140	3/4" X 8-1/4"	8-1/4"	3/4"	3/4"	2-1/4"	90 ft lbs	5	20
Part ID	Description	Usable Length	Diameter	ANSI Drill Diameter	Max. Fixture Thickness	Max. Torque	Box Quantity	Carton Quantity
SAA145800	1/4" X 5/8"	5/8"	1/4"	1/4"	1/2"	90 ft lbs	100	1000
SAA141380	1/4" X 1-3/8"	1-3/8"	1/4"	1/4"	1/2"	6 ft lbs	100	800
SAA142140	1/4" X 2-1/4"	2-1/4"	1/4"	1/4"	1/2"	6 ft lbs	100	600
SAC382340	3/8" X 2-3/4"	2-3/4"	3/8"	3/8"	1-1/4"	6 ft lbs	50	300
SAC384000	3/8" X 4"	4"	3/8"	3/8"	1-1/4"	18 ft lbs	50	250
SAC385000	3/8" X 5"	5"	3/8"	3/8"	1-1/4"	18 ft lbs	50	250
SAC386000	3/8" X 6"	6"	3/8"	3/8"	1-1/4"	18 ft lbs	50	250



# Caulking Anchors

Aerosmith®'s Caulking Anchor is an internally threaded part whose sleeve is made of Zamac alloy. This anchor comes pre-assembled and can be used in concrete, brick, block and stone. Pre-drill the proper hole diameter and length, tap anchor into pre-drilled hole and properly set using the proper Aerosmith® caulking setting tool. Once properly set, put fixture in place and use the required machine bolt for proper attachment. This anchor can also be used in normal weight concrete, grout filled concrete, masonry (CMU) brick and stone. This anchor is not recommended for overhead applications.

## APPLICATIONS:

- Window frame installations
- Screens enclosures
- Sliding doors
- Storm shutters
- Light to medium duty signage
- Seating

## FEATURES & BENEFITS:

- Easy to install
- Can be used in a variety of base materials
- Internally threaded anchor for easy removability
- Can be used in shallow embedments
- Corrosion resistant anchor body

## BASE MATERIAL:

- Concrete
- Block
- Brick
- Stone

## ANCHOR COMPONENT MATERIALS:

Lead Alloy Body and internally threaded Zamac Alloy Cone

## CAULKING SETTING TOOLS:

- CIT10 10-24
- CIT14 1/4"
- CIT516 5/16"
- CIT38 3/8"
- CIT12 1/2"

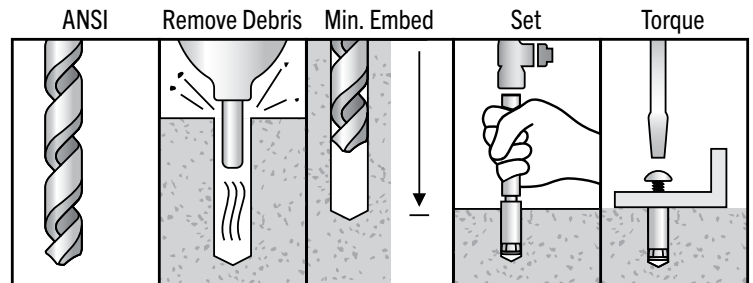

Part ID	Description	ANSI Drill Diameter	Min. Embed	Max. Torque	Box Quantity	Carton Quantity	Use with Caulking Tool
CI1024	Caulking 10 - 24	3/8"	5/8"	20 lbs Max	100	1000	CIT10
CI1420	Caulking 1/4" - 20	1/2"	7/8"	60 lbs Max	100	600	CIT14
CI51618	Caulking 5/16" - 18	5/8"	1"	7 ft. lbs Max	50	300	CIT516
CI3816	Caulking 3/8" - 16	3/4"	1-1/4"	10 ft.-lbs Max	50	300	CIT38
CI1213	Caulking 1/2" - 13	7/8"	1-1/2"	15 ft.-lbs Max	50	250	CIT12
Use with Caulking Anchor							
CIT10	Caulking Setting Tool 10 - 24	N/A	-	-	1	300	10 - 24 CI1024
CIT14	Caulking Setting Tool 1/4"	N/A	-	-	1	200	1/4" CI1420
CIT516	Caulking Setting Tool 5/16"	N/A	-	-	1	150	5/16" CI51618
CIT38	Caulking Setting Tool 3/8"	N/A	-	-	1	100	3/8" CI3816
CIT12	Caulking Setting Tool 1/2"	N/A	-	-	1	60	1/2" CI1213

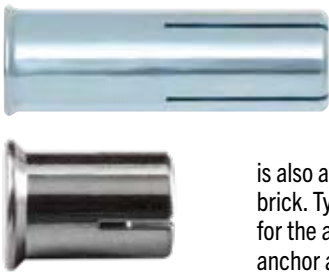

# Drop-ins

Aerosmith®'s Drop-in is a machine type bolt anchor available in 304 and 316 SS as well as carbon steel. The body is internally threaded for use in flush mount applications and solid base materials. Aerosmith® also offers a coil thread version for concrete forming applications available in both 1/2" and 3/4" diameters. A shallow embedment drop-in is also available which is made from carbon steel and can be used in solid concrete, hollow concrete, plank, hardstone and solid brick. Typical applications include hanging threaded rod overhead. Installation is easy. Pre-drill a hole using the proper diameter for the anchor, tap anchor into pre-drilled hole until flush with base material. Use the appropriate setting tool to properly set the anchor and hammer the back of the setting tool until neck is flush with the top of the anchor. Put fixture in place and insert the machine bolt and tighten to the required torque. If using overhead, insert threaded rod to the minimal thread engagement which should be equal to the nominal diameter of the threaded insert. This product can be used in overhead applications.

## APPLICATIONS:

- Cable trays
- Fire sprinklers
- Suspended conduit
- Concrete form-work
- Suspended ceiling and lighting
- Telecommunication installations

## FEATURES & BENEFITS:

- Easy to remove
- Allows for short embedment
- Lipped version installs flush
- Non-lipped version for deeper embedment
- High load values
- Available in different material types

## BASE MATERIAL:

- Solid concrete
- Hard stone
- Solid block

## APPROVALS:

UL Listed for 3/8" & 1/2" diameters  
Mini Drop-In not included.

## ANCHOR COMPONENT MATERIALS:

- Carbon Steel – Zinc Plated
- Stainless Steel Type 304
- Stainless Steel Type 316

## SETTING TOOL



## SHALLOW EMBED SETTING

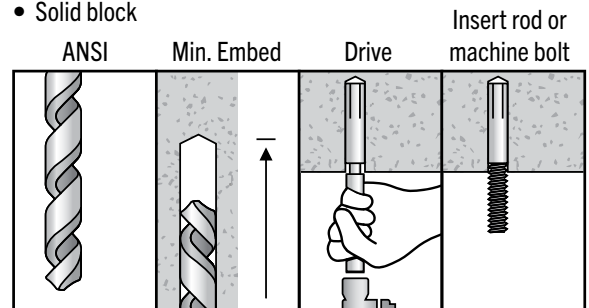

Part ID	Product Name		Description	Overall Length	Thread Diameter	ANSI Drill Diameter	Min. Embed	Rod Size: Torque	Box Quantity	Carton Quantity
DI14	Carbon Steel Drop In		1/4"	1"	1/4"	3/8"	1"	Rod Size: 1/4" Torque 5 ft lbs	100	1000
DI38	Carbon Steel Drop In		3/8"	1-9/16"	3/8"	1/2"	1-9/16"	Rod Size: 3/8" Torque 10 ft lbs	50	500
DI12	Carbon Steel Drop In		1/2"	2"	1/2"	5/8"	2"	Rod Size: 1/2" Torque 20 ft lbs	50	300
DI58	Carbon Steel Drop In		5/8"	2-1/2"	5/8"	7/8"	2-1/2"	Rod Size: 5/8" Torque 40 ft lbs	25	125
DI34	Carbon Steel Drop In		3/4"	3-3/16"	3/4"	1"	3-3/16"	Rod Size: 3/4" Torque 80 ft lbs	10	50
DIC12	Coil Thread Drop in		1/2"	2"	1/2"	5/8"	2"	Rod Size: 1/2" Torque 20 ft lbs	50	300
DIC34	Coil Thread Drop in		3/4"	3-3/16"	3/4"	1"	3-3/16"	Rod Size: 3/4" Torque 80 ft lbs	10	90
DIL14	Carbon Steel Shallow Embedment Drop In		w/Lip 1/4"	5/8"	1/4"	3/8"	5/8"	Rod Size: 1/4" Torque 5 ft lbs	100	1000
DIL38	Carbon Steel Shallow Embedment Drop In		w/Lip 3/8"	3/4"	3/8"	1/2"	3/4"	Rod Size: 3/8" Torque 10 ft lbs	100	1000
DIL12	Carbon Steel Shallow Embedment Drop In		w/Lip 1/2"	1"	1/2"	5/8"	1"	Rod Size: 1/2" Torque 20 ft lbs	25	300
DI4SS14	Stainless Steel Drop In		304 SS 1/4"	1"	1/4"	3/8"	1"	Rod Size: 1/4" Torque 5 ft lbs	100	1000
DI4SS38	Stainless Steel Drop In		304 SS 3/8"	1-9/16"	3/8"	1/2"	1-9/16"	Rod Size: 3/8" Torque 10 ft lbs	50	500
DI4SS12	Stainless Steel Drop In		304 SS 1/2"	2"	1/2"	5/8"	2"	Rod Size: 1/2" Torque 20 ft lbs	50	300
DI6SS14	Stainless Steel Drop In		316 SS 1/4"	1"	1/4"	3/8"	1"	Rod Size: 1/4" Torque 5 ft lbs	100	1000
DI6SS38	Stainless Steel Drop In		316 SS 3/8"	1-9/16"	3/8"	1/2"	1-9/16"	Rod Size: 3/8" Torque 10 ft lbs	50	500
DI6SS12	Stainless Steel Drop In		316 SS 1/2"	2"	1/2"	5/8"	2"	Rod Size: 1/2" Torque 20 ft lbs	50	300
DST14	Drop-In Setting Tool		1/4"						1	250
DST38	Drop-In Setting Tool		3/8"						1	100
DST12	Drop-In Setting Tool		1/2"						1	100
DST58	Drop-In Setting Tool		5/8"						1	50
DST34	Drop-In Setting Tool		3/4"						1	25
DSTM14	Shallow Embedment Drop In Setting Tool		1/4"						1	50
DSTM38	Shallow Embedment Drop In Setting Tool		3/8"						1	50
DSTM12	Shallow Embedment Drop In Setting Tool		1/2"						1	50



# Hollow Block Anchors

Aerosmith®'s Hollow Block anchor is designed for anchoring in hollow base materials such as hollow concrete block, hollow core pre-cast concrete plank, and brick with weep hole. The Hollow Block anchor is a good option to use when the wall thickness available is 1" or less. The anchor design take this issue in account.

## APPLICATIONS:

- Anchoring to concrete block
- Suspending conduit
- Cable trays and strut
- Pipe supports
- Fastening to precast hollow core plank
- Fire sprinkler
- Suspended lighting
- Removable anchorage

## FEATURES & BENEFITS:

- Tapered sleeve
- Serrated cone
- Large bearing area which reduces the amount of compression force applied to the base material during the expansion process

## BASE MATERIAL:

- Concrete
- Block
- Brick
- Pre-cast Hollow Core Plank
- Stone



## ANCHOR COMPONENT MATERIALS:

Zamac Alloy with Carbon Steel Cone

Part ID	Description	Overall Length	Box	Carton Quantity
HBA12	1/2"	1-3/4"	50	250
HBA38	3/8"		50	300
HBAT12	1/2"	Setting Tool		1
HBAT38	3/8"	Setting Tool		1



# Dual Machine Bolt Anchors

Aerosmith®'s Dual Machine Bolt Anchors can be used in solid concrete, brick, block and stone. The Dual Machine Bolt Anchor is made of die cast Zamac alloy and is corrosive resistant. Although the product can be used in many base materials it is sometimes used in questionable materials because it expands against the concrete at two points. Sizes are available from 1/4" to 3/4" diameters. Drill the proper diameter hole to the specified embedment, tap anchor into pre-drill hole until flush. Put fixture in place and insert machine bolt. Tighten to required torque to properly set the anchor. This product is not recommended for overhead applications.

## APPLICATIONS:

- Cable trays
- Scaffolding
- Handrails
- Signage
- Strut
- Machinery
- Light fixtures
- Sprinkler pipe

## FEATURES & BENEFITS:

- Internal thread accepts machine bolts
- Corrosion resistance
- Easy to remove installations

## BASE MATERIAL:

- Concrete
- Grout filled block
- Brick
- Stone

## ANCHOR COMPONENT MATERIALS:

Zinc Alloy

Part ID	Description	Overall Length	ANSI Drill Diameter	Min. Embed	Max. Torque	Box	Carton Quantity
DB14	1/4"	1-3/8"	1/2"	1-1/4"	5 ft lbs	50	500
DB516	5/16"	1-5/8"	5/8"	1-1/2"	7 ft lbs	50	500
DB38	3/8"	2"	3/4"	1-3/4"	10 ft lbs	50	250
DB12	1/2"	2-1/2"	7/8"	2-1/4"	20 ft lbs	25	250
DB58	5/8"	2-3/4"	1"	2-1/2"	20 ft lbs	25	125
DB34	3/4"	3-15/16"	1-1/4"	3-1/2"	60 ft lbs	10	50





# Machine Bolt Anchors

The Machine Bolt Anchor can be used in concrete, block, brick and stone. The anchor consists of a set of expansion shields and an expander cone. The product is manufactured from zinc alloy. As the anchor is tightened, the cone gets drawn into the expansion shield which compresses them against the base material. This product is not recommended in overhead applications.

## APPLICATIONS:

- Cable trays
- Scaffolding
- Handrails
- Signage
- Strut
- Machinery
- Light fixtures
- Sprinkler pipe

## FEATURES & BENEFITS:

- Internal thread accepts machine bolts
- Corrosion resistance
- Easy to remove installations

## BASE MATERIAL: ANCHOR COMPONENT MATERIALS:

- Concrete
- Grout filled block
- Brick
- Stone
- Zinc Alloy

Part ID	Description	Overall Length	ANSI Drill Diameter	Min. Embed	Max. Torque	Box	Carton Quantity
SNG14	1/4"	1-5/16"	1/2"	1-3/8"	5 ft. lbs	50	250
SNG516	5/16"	1-1/2"	5/8"	1-5/8"	7 ft. lbs	50	250
SNG38	3/8"	1-1/2"	5/8"	1-5/8"	10 ft. lbs	50	250
SNG12	1/2"	2-1/16"	7/8"	2-1/2"	20 ft. lbs	25	125
SNG58	5/8"	2-5/8"	1"	2-3/4"	30 ft. lbs	25	125

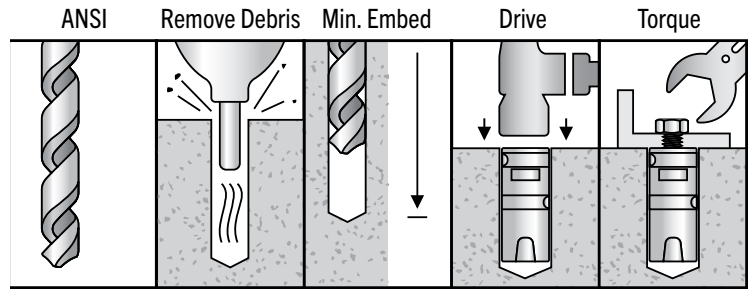

# Sure-Lag

The Aerosmith® Sure-Lag can be used to anchor into a variety of base materials such as concrete, brick and grout filled block. Although best suited for light to medium duty fastening. Sure-Lag Anchors are available in 1/4", 5/16", 3/8", 1/2", 5/8" diameters, and are available in both short and long versions. The short version is typically used on harder base materials while the longer Sure-Lags are typically used on softer base materials where more embedment is required. Sure-Lags are made from zinc which enables them to be used in many different environmental conditions. To set, drill the proper size hole, tap Sure-Lag into the base material, put fixture in place and thread machine bolt into the Sure-Lag until tight. The fixture is removable because the Sure-Lag anchor remains in the hole and only the lag screw can be unscrewed and removed. Not recommended for overhead applications.

## APPLICATIONS:

- Light to medium duty signage
- Electrical boxes
- Hand rails
- Anchoring strut to masonry walls

## FEATURES & BENEFITS:

- Removable
- Can be used in a variety of base materials
- Non-corrosive

## BASE MATERIAL: ANCHOR COMPONENT MATERIALS:

- Concrete
- Grout filled block
- Brick
- Zinc Alloy

Part ID	Description	ANSI Drill Diameter	Min. Embed	Max. Torque	Box Quantity	Carton Quantity
LS14S	1/4" Short	1/2"	1"	5 ft lbs	50	500
LS14L	1/4" Long	1/2"	1-1/2"	5 ft lbs	50	500
LS516S	5/16" Short	1/2"	1-1/4"	7 ft lbs	50	500
LS516L	5/16" Long	1/2"	1-3/4"	7 ft lbs	50	500
LS38S	3/8" Short	5/8"	1-3/4"	10 ft lbs	50	500
LS38L	3/8" Long	5/8"	2-1/2"	10 ft lbs	50	250
LS12S	1/2" Short	3/4"	2"	20 ft lbs	50	500
LS12L	1/2" Long	3/4"	3"	20 ft lbs	50	200
LS58S	5/8" Short	7/8"	2"	30 ft lbs	25	125

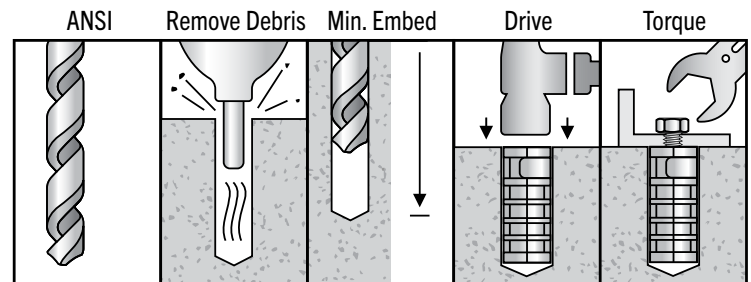

# SDS-Plus 4 Cutter Carbide Drill Bits for Concrete, Brick, Block and Stone

The SDS carbide tipped drill bit is a masonry bit designed for concrete drilling. But unlike ordinary bits, the SDS drill bit provides a longer service life. These carbide tipped masonry drill bits are more durable due to the hardness of the heads-making them tougher and more resistant to extreme loads.

## FEATURES & BENEFITS:

- 4 Cutter Head.
- Reduces operator fatigue.
- Provides a longer service life of the tool. Clip designed for easy display.
- To be used in Concrete, Brick, Block and Stone.
- Flute design for fast dust extraction.



**4 Cutter Head.**

**Reduces operator fatigue.**

**Provides a longer service life of the tool.**

Part ID	Description	Box Quantity	Carton Quantity
SDS532600	SDS CARBIDE DRILL 5/32 X 4 X 6	1	1
SDS316400	SDS CARBIDE DRILL 3/16 X 2 X 4	1	1
SDS316600	SDS CARBIDE DRILL 3/16 X 4 X 6	1	1
SDS316800	SDS CARBIDE DRILL 3/16 X 6 X 8	1	1
SDS732800	SDS CARBIDE DRILL 7/32 X 6 X 8	1	1
SDS144000	SDS CARBIDE DRILL 1/4 X 2 X 4	1	1
SDS146000	SDS CARBIDE DRILL 1/4 X 4 X 6	1	1
SDS148000	SDS CARBIDE DRILL 1/4 X 6 X 8	1	1
SDS141200	SDS CARBIDE DRILL 1/4 X 10 X 12	1	1
SDS141400	SDS CARBIDE DRILL 1/4 X 12 X 14	1	1
SDS516600	SDS CARBIDE DRILL 5/16 X 4 X 6	1	1
SDS516120	SDS CARBIDE DRILL 5/16 X 10 X 12	1	1
SDS386000	SDS CARBIDE DRILL 3/8 X 4 X 6	1	1
SDS381000	SDS CARBIDE DRILL 3/8 X 8 X 10	1	1
SDS381200	SDS CARBIDE DRILL 3/8 X 10 X 12	1	1
SDS381800	SDS CARBIDE DRILL 3/8 X 16 X 18	1	1
SDS126000	SDS CARBIDE DRILL 1/2 X 4 X 6	1	1
SDS121000	SDS CARBIDE DRILL 1/2 X 8 X 10	1	1
SDS121200	SDS CARBIDE DRILL 1/2 X 10 X 12	1	1
SDS121800	SDS CARBIDE DRILL 1/2 X 16 X 18	1	1
SDS122600	SDS CARBIDE DRILL 1/2 X 24 X 26	1	1
SDS588000	SDS CARBIDE DRILL 5/8 X 6 X 8	1	1
SDS581200	SDS CARBIDE DRILL 5/8 X 10 X 12	1	1
SDS581800	SDS CARBIDE DRILL 5/8 X 16 X 18	1	1
SDS348000	SDS CARBIDE DRILL 3/4 X 6 X 8	1	1
SDS341200	SDS CARBIDE DRILL 3/4 X 10 X 12	1	1
SDS341800	SDS CARBIDE DRILL 3/4 X 16 X 18	1	1

# MEDIUM TO LIGHT DUTY MECHANICAL ANCHORS

## Strike Anchors

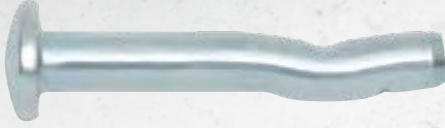

Aerosmith®'s Strike Anchor is a one-piece multi-purpose fastener specifically designed to be used in concrete, brick, grout filled block and stone. The anchor has a pre-expanded bend at the bottom of the anchor which straightens out to conform to the walls of the hole when hammered into the proper size pre-drilled hole. The anchor will always try to regain its preexpanded bend which causes constant expansion pressure within the hole. This eliminates the need for any additional tightening or secondary setting operation. Sizes range from 3/16" diameter to 3/8" and are also available in multiple head styles. The mushroom head version makes an excellent choice for many tamper proof operations.

## Sure-Con® Concrete Screws



Aerosmith®'s Sure-Con® Concrete Screws are designed to meet the demands of most light to medium duty applications. The screws are hardened and come with a blue and white environmental coating which allows them to be used in dry interior applications and some exterior applications. The product can be used in concrete, block and brick and manufactured with either a hex washer head or Phillips head. Just pre-drill a hole using a proper size concrete drill bit and run the anchor into the pre-drilled hole. Each box of screws contains one drill bit.

## 410 Stainless Steel Sure-Cons®



The Aerosmith® Stainless Steel Sure-Con® is a light to medium duty mechanical anchor that is made from 410 Stainless steel. It is available in both a finished Hex head or Phillips head in 3/16 and 1/4 diameters up to 3 3/4 in length. Its properties allow this screw to be used in internal applications but can also be used in some external applications where applicable. The product is designed to be used in concrete, brick and block and requires installation using a Sure-Con® drill bit for maximum performance. A drill bit is included in each box of screws. Installation is fast and easy, just predrill your hole using the proper Sure-Con® drill bit to the required depth and run your screw through your fixture either using a cordless/corded screw gun or impact using the required torque value.

## Sure-Con® Concrete Screw Carbide Bits



Sure-Con® Carbide Concrete Bits for 3/16" and 1/4" concrete screws. (Blue and White)

## Concrete Hangerz



Aerosmith®'s Concrete Hangerz are designed for suspending threaded rod vertically overhead for pipe hanging, fire protection, electrical conduit and cable tray applications. The one-piece design makes it easy to install and is available with three different coupler sizes. Just drill the same diameter hole as the anchor body and run the anchor into pre-drilled hole using a corded or cordless impact wrench or a standard hand socket.

## Wood Vertical Hangerz



Aerosmith®'s Wood Vertical Hangerz are a one-piece, all steel threaded fastening system for suspending steel threaded rod vertically overhead in pipe hanging, fire protection, electrical conduit and cable-tray applications. Parts come with a #17 Point for fast drilling into wood beams. Can be installed with a screw gun or hammer drill in rotation mode only.

## Steel Vertical Hangerz

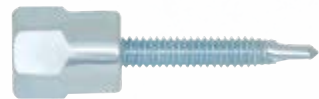

Aerosmith®'s Steel Vertical Hangerz are an all steel fastening system that is used for suspending threaded rod vertically for pipe hanging, fire protection, electrical conduit and cable tray applications. The anchor is easy to install by just running the parts with a screw gun or hammer drill in rotation only mode. It is recommended the parts be installed using the Aerosmith® universal socket.

## Zinc & SS Nail-ins



Aerosmith®'s Zinc Nail-in Anchor is a light duty tamper proof anchor whose body is made of zinc alloy. The anchor can be purchased with either a carbon steel nail or a stainless steel nail depending on the application. The zinc nail-in can be used in concrete, block, brick and stone and is easy to install. Pre-drill the same diameter hole as the anchor body, position fixture in place, tap anchor into the pre-drilled hole, when flush, hammer the nail into the body of the anchor. Since the anchor body is made of zinc alloy, it is corrosive resistant when used in conjunction with the stainless steel nail. This anchor should not be used in overhead applications.

## Split Anchor Drive



Aerosmith®'s Split Drive anchor is a one piece, all steel mechanical anchor that can be used in concrete, brick, and stone. Its available in a 1/4 diameter, up to 4 inches in length. It comes with a flat head, aka counter sunk and is ideal for applications where the fastening needs to either be permanent or tamper proof. It also works extremely well in wood to concrete connections. Just drill a hole the same diameter as the anchor and hammer it through your fixture and into the base material. It is that simple.

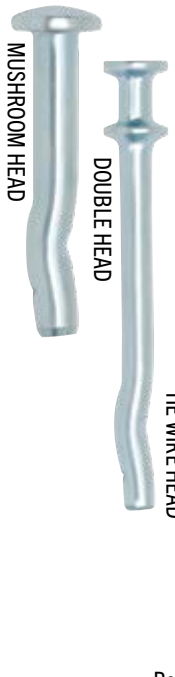

# Strike Anchors

Aerosmith®'s Strike Anchor is a one-piece multi-purpose fastener specifically designed to be used in concrete, brick, grout filled block and stone. The anchor has a pre-expanded bend at the bottom of the anchor which straightens out to conform to the walls of the hole when hammered into the proper size pre-drilled hole. The anchor will always try to regain its pre-expanded bend which causes constant expansion pressure within the hole. This eliminates the need for any additional tightening or secondary setting operation. Sizes range from 3/16" diameter to 3/8" and are also available in multiple head styles. The mushroom head version makes an excellent choice for many tamper proof applications.

## APPLICATIONS:

- Pipe hanging
- Cable trays
- Metal track to concrete
- Security fixtures
- Concrete formwork
- Bicycle racks
- HVAC straps
- Electrical boxes
- Signage

## FEATURES & BENEFITS:

- One-piece pre-expanding anchor
- Tamper resistant (flat and mushroom head)
- No secondary setting operation
- Hole size is the same as anchor size
- No special tools required

## BASE MATERIAL:

- Concrete
- Brick
- Grout filled block
- Stone

## ANCHOR COMPONENT MATERIALS:

Anchor Body AISI 1038 Carbon Steel, Zinc Plated

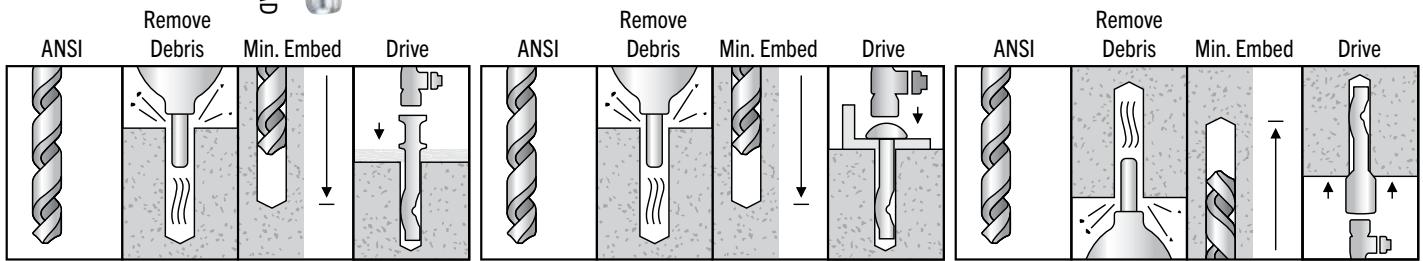

**DOUBLE HEAD STRIKE**

**MUSHROOM HEAD STRIKE**

**INTERNALLY THREADED STRIKE**

Part ID	Product Name	Description	Overall Length	Diameter	MUST USE ANSI Drill Bit	Min. Embed	Box Quantity	Carton Quantity
SPM316100	Zinc Strike	3/16" X 1" (Mushroom Head)	1"	3/16"	3/16"	7/8"	100	1200
SPM316114	Zinc Strike	3/16" X 1-1/4" (Mushroom Head)	1-1/4"	3/16"	3/16"	7/8"	100	1200
SPM316112	Zinc Strike	3/16" X 1-1/2" (Mushroom Head)	1-1/2"	3/16"	3/16"	1-1/4"	100	1200
SPM316200	Zinc Strike	3/16" X 2" (Mushroom Head)	2"	3/16"	3/16"	1-1/4"	100	1200
SPM316212	Zinc Strike	3/16" X 2-1/2" (Mushroom Head)	2-1/2"	3/16"	3/16"	1-1/4"	100	1200
SPM316300	Zinc Strike	3/16" X 3" (Mushroom Head)	3"	3/16"	3/16"	1-1/4"	100	800
SPM316400	Zinc Strike	3/16" x 4" (Mushroom Head)	4"	3/16"	3/16"	1-1/4"	100	800
SPM141000	Zinc Strike	1/4" X 1" (Mushroom Head)	1"	1/4"	1/4"	7/8"	100	1200
SPM141140	Zinc Strike	1/4" X 1-1/4" (Mushroom Head)	1-1/4"	1/4"	1/4"	1"	100	1200
SPM141120	Zinc Strike	1/4" X 1-1/2" (Mushroom Head)	1-1/2"	1/4"	1/4"	1-1/4"	100	1200
SPM142000	Zinc Strike	1/4" X 2" (Mushroom Head)	2"	1/4"	1/4"	1-1/4"	100	800
SPM142120	Zinc Strike	1/4" X 2-1/2" (Mushroom Head)	2-1/2"	1/4"	1/4"	1-1/4"	100	800
SPM143000	Zinc Strike	1/4" X 3" (Mushroom Head)	3"	1/4"	1/4"	1-1/4"	100	800
SPM143120	Zinc Strike	1/4" X 3-1/2" (Mushroom Head)	3-1/2"	1/4"	1/4"	1-1/4"	100	800
SPM144000	Zinc Strike	1/4" X 4" (Mushroom Head)	4"	1/4"	1/4"	1-1/4"	100	800
SPM382000	Zinc Strike	3/8" x 2" (Mushroom Head)	2"	3/8"	3/8"	1-3/4"	25	300
SPM382120	Zinc Strike	3/8" X 2-1/2" (Mushroom Head)	2-1/2"	3/8"	3/8"	1-3/4"	25	300
SPM383000	Zinc Strike	3/8" X 3" (Mushroom Head)	3"	3/8"	3/8"	1-3/4"	25	300
SPM384000	Zinc Strike	3/8" X 4" (Mushroom Head)	4"	3/8"	3/8"	1-3/4"	25	200
SPM385000	Zinc Strike	3/8" X 5" (Mushroom Head)	5"	3/8"	3/8"	1-3/4"	25	150
STW316	Strike	3/16" (Tie Wire Head)	1-1/8"	3/16"	3/16"	1-1/4"	100	800
STW140	Strike	1/4" (Tie Wire Head)	1-1/8"	1/4"	1/4"	1-1/4"	100	800
SPF316112	Double Head Strike	3/16" X 1-1/2"	1-1/2"	3/16"	3/16"	1-1/4"	100	1200
SPF316200	Double Head Strike	3/16" X 2"	2"	3/16"	3/16"	1-1/4"	100	800
SPF316234	Double Head Strike	3/16" X 2-3/4"	2-3/4"	3/16"	3/16"	1-1/4"	100	600
SPF142340	Double Head Strike	1/4" X 2-3/4"	2-3/4"	1/4"	1/4"	1-1/4"	100	600
SPP14	Strike Internally Threaded	1/4" body with 1/4" Coupler	1-1/4"	1/4"	1/4"	1-1/4"	100	1200
SPP38	Strike Internally Threaded	1/4" body with 3/8" Coupler	1-3/4"	1/4"	1/4"	1-3/4"	50	400



# Sure-Con® Concrete Screws

Tested in accordance with AC 193, AC 106, AC 233, AC 257 criteria



Aerosmith's Sure-Con® Concrete Screws are designed to meet the demands of most light to medium duty applications. The screws are hardened and come with a blue or white environmental coating which allows them to be used in dry interior applications and some exterior applications. The product can be used in concrete, block and brick and manufactured with either a hex washer head or phillips head. Just pre-drill a hole using a proper size concrete drill bit and run anchor into pre-drill hole. Each box of screws contains one drill bit.

## APPLICATIONS:

- Metal door frames
- Window installations
- Shutters
- Joint flashings
- Electrical boxes
- Light fixtures
- Signage
- Electrical junction boxes
- Conduit clips to masonry.
- Wood headers/furring strips to masonry
- HVAC straps to masonry
- Plywood to masonry
- Exterior insulation to masonry

## FEATURES & BENEFITS:

- Available in both slotted hex head and phillips flat head
- No hole spotting required
- Product cuts its own threads into masonry
- Coating reduces corrosion
- Can be used in light to medium duty applications

## BASE MATERIAL: HEAD STYLES:

- Concrete
- Masonry



Phillips



Slotted Hex Head

## ANCHOR COMPONENT MATERIALS:

Body- Heat treated Carbon Steel, Coating- Environmental (Blue)

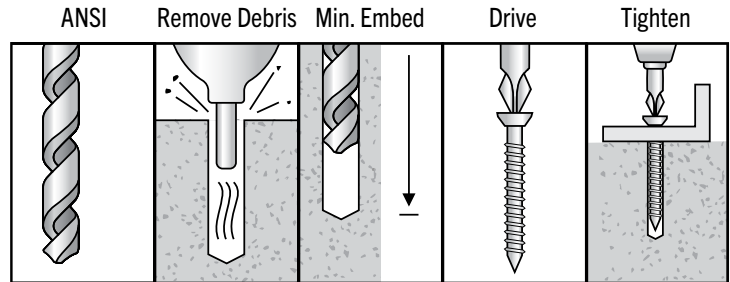

## PHILLIPS HEAD

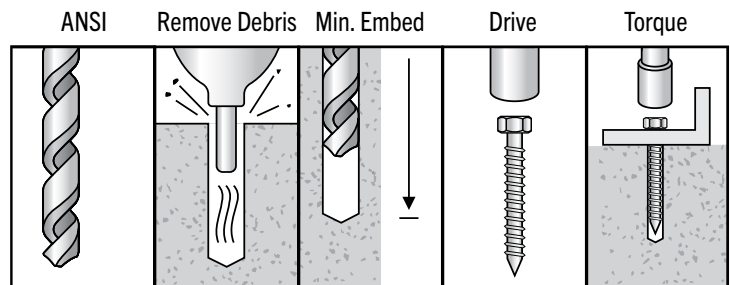

## HEX HEAD

Part ID	Description	Overall Length	Diameter	Min. Embed	Drill Bit	Box Quantity	Carton Quantity
TCH316114*	3/16" X 1-1/4"	1-1/4"	3/16"	1-1/4"	5/32"	100	500
TCH316134*	3/16" X 1-3/4"	1-3/4"	3/16"	1-1/4"	5/32"	100	500
TCH316214	3/16" X 2-1/4"	2-1/4"	3/16"	1-1/4"	5/32"	100	500
TCH316234	3/16" X 2-3/4"	2-3/4"	3/16"	1-1/4"	5/32"	100	500
TCH316314	3/16" X 3-1/4"	3-1/4"	3/16"	1-1/4"	5/32"	100	500
TCH316334	3/16" X 3-3/4"	3-3/4"	3/16"	1-1/4"	5/32"	100	500
TCH316400	3/16" X 4"	4"	3/16"	1-1/4"	5/32"	100	500
TCH141140*	1/4" X 1-1/4"	1-1/4"	1/4"	1-1/4"	3/16"	100	500
TCH141340	1/4" X 1-3/4"	1-3/4"	1/4"	1-1/4"	3/16"	100	500
TCH142140	1/4" X 2-1/4"	2-1/4"	1/4"	1-1/4"	3/16"	100	500
TCH142340	1/4" X 2-3/4"	2-3/4"	1/4"	1-1/4"	3/16"	100	500
TCH143140	1/4" X 3-1/4"	3-1/4"	1/4"	1-1/4"	3/16"	100	500
TCH143340	1/4" X 3-3/4"	3-3/4"	1/4"	1-1/4"	3/16"	100	500
TCH144000	1/4" X 4"	4"	1/4"	1-1/4"	3/16"	100	500

\*This size is less than required minimum standard anchor length for strength design

Part ID	Description	Overall Length	Diameter	Min. Embed	Drill Bit	Box Quantity	Carton Quantity
TCP316114*	3/16" X 1-1/4"	1-1/4"	3/16"	1-1/4"	5/32"	100	500
TCP316134*	3/16" X 1-3/4"	1-3/4"	3/16"	1-1/4"	5/32"	100	500
TCP316214	3/16" X 2-1/4"	2-1/4"	3/16"	1-1/4"	5/32"	100	500
TCP316234	3/16" X 2-3/4"	2-3/4"	3/16"	1-1/4"	5/32"	100	500
TCP316314	3/16" X 3-1/4"	3-1/4"	3/16"	1-1/4"	5/32"	100	500
TCP316334	3/16" X 3-3/4"	3-3/4"	3/16"	1-1/4"	5/32"	100	500
TCP316400	3/16" X 4"	4"	3/16"	1-1/4"	5/32"	100	500
TCP141140*	1/4" X 1-1/4"	1-1/4"	1/4"	1-1/4"	3/16"	100	500
TCP141340*	1/4" X 1-3/4"	1-3/4"	1/4"	1-1/4"	3/16"	100	500
TCP142140	1/4" X 2-1/4"	2-1/4"	1/4"	1-1/4"	3/16"	100	500
TCP142340	1/4" X 2-3/4"	2-3/4"	1/4"	1-1/4"	3/16"	100	500
TCP143140	1/4" X 3-1/4"	3-1/4"	1/4"	1-1/4"	3/16"	100	500
TCP143340	1/4" X 3-3/4"	3-3/4"	1/4"	1-1/4"	3/16"	100	500
TCP144000	1/4" X 4"	4"	1/4"	1-1/4"	3/16"	100	500
TCP145000	1/4" X 5"	5"	1/4"	1-1/4"	3/16"	100	500
TCP146000	1/4" X 6"	6"	1/4"	1-1/4"	3/16"	100	500

# 410 Stainless Steel Sure-Cons®

Tested in accordance with AC 193, AC 106, AC 233, AC 257 criteria

Sure-Con® Concrete Screws Hex Head and Phillips Head- White

Sure-Con® Concrete Screws Hex Head and Phillips Head- 410 SS

Aerosmith®'s Stainless Steel Sure-Con® is a light to medium duty mechanical anchor that is made from 410 Stainless steel. It is available in both a finished Hex head or Phillips head in 3/16 and 1/4 diameters up to 3 3/4 in length. Its properties allow this screw to be used in internal applications but can also be used in some external applications where applicable. The product is designed to be used in concrete, brick and block and requires installation using a Sure-Con® drill bit for maximum performance. A drill bit is included in each box of screws. Installation is fast and easy, just predrill your hole using the proper Sure-Con® drill bit to the required depth and run your screw through your fixture either using a cordless/corded screw gun or impact using the required torque value.

## APPLICATIONS:

- Metal door frames
- Window installations
- Shutters
- Joint flashings
- Electrical boxes
- Light fixtures
- Signage
- Electrical junction boxes
- Conduit clips to masonry.
- Wood headers/furring strips to masonry
- HVAC straps to masonry
- Plywood to masonry
- Exterior insulation to masonry

## FEATURES & BENEFITS:

- Available in both slotted hex head and phillips flat head
- No hole spotting required
- Product cuts its own threads into masonry
- Coating reduces corrosion
- Can be used in light to medium duty applications

## ANCHOR COMPONENT MATERIALS:

- Body- Heat treated Carbon Steel
- Coating- Environmental (410 SS and White)

## BASE MATERIAL:

- Masonry

## HEAD STYLES:

Phillips



Hex Head

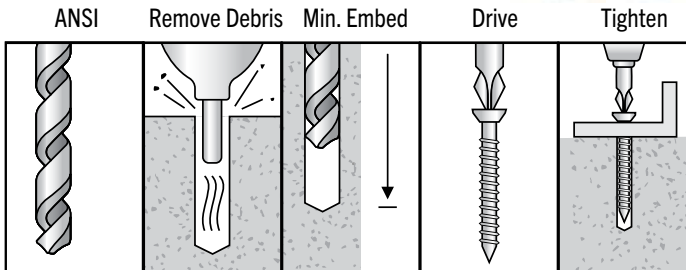

## PHILLIPS HEAD

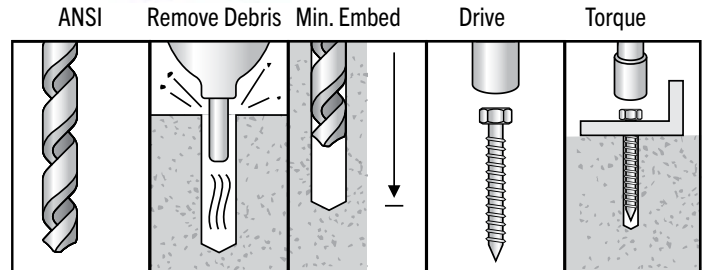

## HEX HEAD

### Sure-Con® Concrete Screws Hex Head - White & Stainless Steel

Part ID	Description	Overall Length	Diameter	Min. Embed	Drill Bit	Total torque	Box Quantity	Carton Quantity
TCH141140W & TCH4SS141140	1/4" x 1-1/4"	1-1/4" *	1/4"	1"	3/16" Sure -Bit	5 ft lbs.	100	500
TCH141340W & TCH4SS141340	1/4" x 1-3/4"	1-3/4" *	1/4"	1-1/4"	3/16" Sure -Bit	5 ft lbs.	100	500
TCH142140W & TCH4SS142140	1/4" x 2-1/4"	2-1/4" *	1/4"	1-1/4"	3/16" Sure -Bit	5 ft lbs.	100	500
TCH142340W & TCH4SS142340	1/4" x 2-3/4"	1-1/4" *	1/4"	1-1/4"	3/16" Sure -Bit	5 ft lbs.	100	500
TCH143140W & TCH4SS143140	1/4" x 3-1/4"	3-1/4" *	1/4"	1-1/4"	3/16" Sure -Bit	5 ft lbs.	100	500
TCH143340W & TCH4SS143340	1/4" x 3-3/4"	3-3/4" *	1/4"	1-1/4"	3/16" Sure -Bit	5 ft lbs.	100	500
TCH316114W & TCH4SS316114	3/16" x 1-1/4"	1-1/4" *	3/16"	1-1/4"	5/32" Sure -Bit	3 ft lbs.	100	500
TCH316134W	3/16" x 1-3/4"	1-3/4" *	3/16"	1-1/4"	5/32" Sure -Bit	3 ft lbs.	100	500
TCH316214W & TCH4SS316214	3/16" x 2-1/4"	2-1/4" *	3/16"	1-1/4"	5/32" Sure -Bit	3 ft lbs.	100	500
TCH316234W & TCH4SS316234	3/16" x 2-3/4"	2-3/4" *	3/16"	1-1/4"	5/32" Sure -Bit	3 ft lbs.	100	500
TCH316314W	3/16" x 3-1/4"	3-1/4" *	3/16"	1-1/4"	5/32" Sure -Bit	3 ft lbs.	100	500

### Sure-Con® Concrete Screws Phillips Head - White & Stainless Steel

Part ID	Description	Overall Length	Diameter	Min. Embed	Drill Bit	Total torque	Box Quantity	Carton Quantity
TCP141140W & TCP4SS141140	1/4" x 1-1/4"	1-1/4" *	1/4"	1"	3/16" Sure -Bit	5 ft lbs.	100	500
TCP141340W & TCP4SS141340	1/4" x 1-3/4"	1-3/4" *	1/4"	1-1/4"	3/16" Sure -Bit	5 ft lbs.	100	500
TCP142140W & TCP4SS142140	1/4" x 2-1/4"	2-1/4" *	1/4"	1-1/4"	3/16" Sure -Bit	5 ft lbs.	100	500
TCP142340W & TCP4SS142340	1/4" x 2-3/4"	1-1/4" *	1/4"	1-1/4"	3/16" Sure -Bit	5 ft lbs.	100	500
TCP143140W & TCP4SS143140	1/4" x 3-1/4"	3-1/4" *	1/4"	1-1/4"	3/16" Sure -Bit	5 ft lbs.	100	500
TCP144000W	1/4" x 4"	4"	1/4"	1-1/4"	3/16" Sure -Bit	5 ft lbs.	100	500
TCP316114W & TCP4SS316114	3/16" x 1-1/4"	1-1/4" *	3/16"	1-1/4"	5/32" Sure -Bit	3 ft lbs.	100	500
TCP316134W & TCP4SS316134	3/16" x 1-3/4"	1-3/4" *	3/16"	1-1/4"	5/32" Sure -Bit	3 ft lbs.	100	500
TCP316214W & TCP4SS316214	3/16" x 2-1/4"	2-1/4" *	3/16"	1-1/4"	5/32" Sure -Bit	3 ft lbs.	100	500
TCP316234W & TCP4SS316234	3/16" x 2-3/4"	2-3/4" *	3/16"	1-1/4"	5/32" Sure -Bit	3 ft lbs.	100	500
TCP316314W	3/16" x 3-1/4"	3-1/4" *	3/16"	1-1/4"	5/32" Sure -Bit	3 ft lbs.	100	500

# Sure-Con<sup>®</sup> Concrete Screw Carbide Bits

Sure-Con<sup>®</sup> Concrete Screw Bits are to be used for the installation of Aerosmith<sup>®</sup>'s 1/4" - 3/16" concrete screws.

Part ID	Description	Diameter	Overall Length	Bag	Carton Quantity
CSB532312	Concrete Screw Bits 5/32" X 3-1/2"	3-1/2"	5/32"	10 per bag	50
CSB532412	Concrete Screw Bits 5/32" X 4-1/2"	4-1/2"	5/32"	10 per bag	50
CSB532512	Concrete Screw Bits 5/32" X 5-1/2"	5-1/2"	5/32"	10 per bag	50
CSB316312	Concrete Screw Bits 3/16" X 3-1/2"	3-1/2"	3/16"	10 per bag	50
CSB316412	Concrete Screw Bits 3/16" X 4-1/2"	4-1/2"	3/16"	10 per bag	50
CSB316512	Concrete Screw Bits 3/16" X 5-1/2"	5-1/2"	3/16"	10 per bag	50
CSB316612	Concrete Screw Bits 3/16" X 6-1/2"	6-1/2"	3/16"	10 per bag	50
CSB316712	Concrete Screw Bits 3/16" X 7-1/2"	7-1/2"	3/16"	10 per bag	50

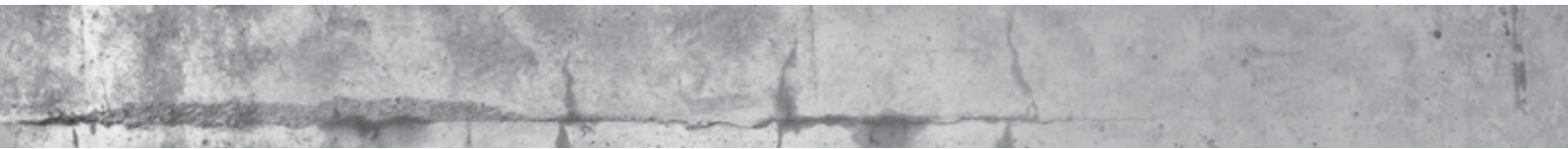



# Concrete Hangerz

Aerosmith®'s Concrete Hangerz are designed for suspending threaded rod vertically overhead for pipe hanging fire protection, electrical conduit and cable tray applications. The one-piece design makes it easy to install and is available with three different coupler sizes. Just drill the same diameter hole as the anchor body and run the anchor into pre-drilled hole using a corded or cordless impact wrench or standard hand socket.

## APPLICATIONS:

- Suspended ceilings
- Cable trays
- Overhead utilities
- Air conditioning
- Ventilation systems
- Lighting systems

## FEATURES & BENEFITS:

- Quick installation time
- Stress applied across full length of anchor
- Can be installed close to edge applications
- Fully removable

## BASE MATERIAL:

- Stone
- Concrete
- Block
- Brick

## ANCHOR COMPONENT MATERIALS:

- Carbon Steel - with Zinc plating

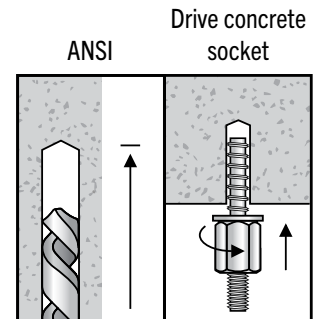

Part ID	Description	Usable Length	Diameter	Insert Rod	Box Quantity	Carton Quantity
VHC1411414	Concrete Hanger 1/4" x 1-1/4" with 1/4" Coupler	1-1/4"	1/4"	Insert 1/4" Rod	25	250
VHC1411238	Concrete Hanger 1/4" x 1-1/2" with 3/8" Coupler	1-1/2"	1/4"	Insert 3/8" Rod	25	250
VHC3823412	Concrete Hanger 3/8" x 2-3/4" with 1/2" Coupler	2-3/4"	3/8"	Insert 1/2" Rod	25	200



# Wood Vertical Hangerz

Aerosmith®'s Wood Vertical Hangerz is an all steel threaded fastener used for suspending threaded rod in wood base materials. The anchor is easy to install by running the parts with a screw gun or hammer drill in rotation only mode. It is recommended the parts be installed using the Aerosmith® socket.

## APPLICATIONS:

- Hanging Pipe and Sprinkler Systems
- Lighting Systems and Overhead Utilities
- Suspended Ceilings
- Suspending Conduit
- Cable Trays
- HVAC Ductwork
- Strut Channels
- Security Equipment

## FEATURES & BENEFITS:

- Quick installation time
- Stress applied across full length of anchor
- Can be installed close to edge applications
- Fully removable

## BASE MATERIAL:

- Wood frame columns
- Wood frame beams

## ANCHOR COMPONENT MATERIALS:

Zinc Plated Carbon Steel #17 Point

Part ID	Description	Usable Length	Diameter	Insert Rod	Box Quantity	Carton Quantity
VHW14214	Wood Hanger 1/4" x 2" with 1/4" Coupler	2"	1/4"	Insert 1/4" Rod	25	250
VHW14238	Wood Hanger 1/4" x 2" with 3/8" Coupler	2"	3/8"	Insert 3/8" Rod	25	250
VHW51621238	Wood Hanger 5/16" x 2-1/2" with 3/8" Coupler	2-1/2"	3/8"	Insert 3/8" Rod	25	250

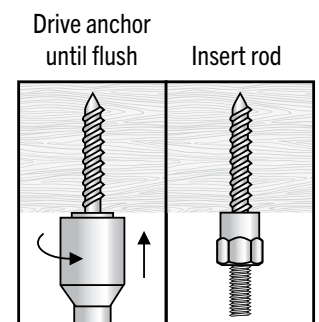





# Steel Vertical Hangerz

Aerosmith®'s Steel Vertical Hangerz are an all steel fastening system that is used for suspending threaded rod vertically for pipe hanging, fire protection, electrical conduit and cable tray applications. The anchor is easy to install by just running the parts with a screw gun or hammer drill in rotation only mode. It is recommended the parts be installed using the Aerosmith® socket.

## APPLICATIONS:

- Hanging pipe and sprinkler systems
- Lighting systems and overhead utilities
- Suspended ceilings
- Suspending conduit
- Cable trays
- HVAC ductwork
- Strut channels
- Security equipment

## FEATURES & BENEFITS:

- Rod hanging application system in steel
- Rapid installation for overhead applications
- Steel Hangerz can be installed with a hammer drill (rotation only) or screw gun

## BASE MATERIAL:

- Steel bar joists
- Wood column
- Steel beams

## ANCHOR COMPONENT MATERIALS:

Zinc Plated Carbon Steel #3 Point

Part ID	Description	Usable Length	Diameter	Insert Rod	Box Quantity	Carton Quantity
VHS14114	Steel Hanger 1/4" x 1" with 1/4" Coupler	1"	1/4"	Insert 1/4" Rod	25	250
VHS14138WN	Steel Hanger 1/4" x 1" w/nut-3/8" Coupler	1"	3/8"	Insert 3/8" Rod	25	250
VHS1411238N	Steel Hanger 1/4" x 1-1/2" w/nut-3/8" Coupler	1-1/2"	3/8"	Insert 3/8" Rod	25	250
VHS122011238N	Steel Hanger 12- 20 x 1-1/2" w/nut-1/2" Coupler	1-1/2"	1/2"	Insert 1/2" Rod	25	250

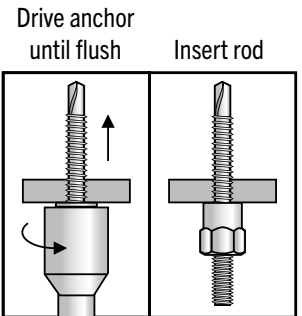

Socket for Steel & Wood

# Sockets

Part ID	Description	Box Quantity	Carton Quantity
US1	Steel & Wood Socket	5	25
CS14	1/4" Concrete Socket	5	25
CS38	3/8" Concrete Socket	5	25
CS12	1/2" Concrete Socket	5	25



Concrete Socket



Zinc Nail-ins

# Zinc Nail-in Anchors

Aerosmith®'s Zinc Nail-in Anchor is a light duty tamper proof anchor whose body is made of zinc alloy. The anchor can be purchased with either a carbon steel nail or a stainless steel nail depending on the application. The zinc nail-in can be used in concrete, block, brick and stone and is easy to install. Pre-drill the same diameter hole as the anchor body, position fix ure in place, tap anchor into the pre-drilled hole, when flush, hammer the nail into the body of the anchor. Since the anchor body is made of zinc alloy, it is corrosive resistant when used in conjunction with the stainless steel nail. This anchor should not be used in overhead applications.

## APPLICATIONS:

- Drywall track
- Light duty signage
- Brick ties
- Parapet flashing

## FEATURES & BENEFITS:

- Fast installation
- Nails available in stainless steel
- No special tools needed
- Can be used in a variety of base materials
- Flush appearance when properly set
- Available in removable version

## BASE MATERIAL:

- Concrete
- Brick
- Block
- Stone



SS Nail-ins

## ANCHOR COMPONENT MATERIALS:

- Zinc Zamac Alloy (Body)
- Carbon Steel (Nail) AISI 1018
- Stainless Steel (Nail) Type 304 SS

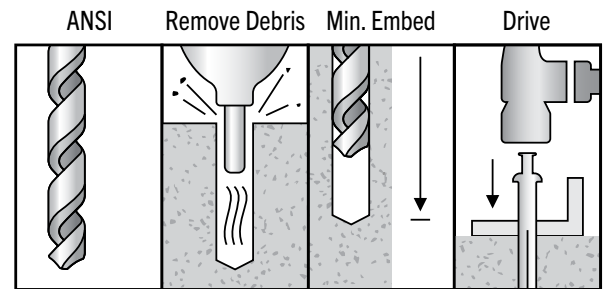

Part ID	Product Name	Description	Overall Length	Overall Diameter	ANSI Drill Diameter	Min. Embed	Box Quantity	Carton Quantity
ZNMH31678	Zinc Nail-In	3/16 X 7/8 (Mushroom Head)	7/8"	3/16"	3/16"	3/4"	100	500
ZNMH1434	Zinc Nail-In	1/4 X 3/4 (Mushroom Head)	3/4"	1/4"	1/4"	5/8"	100	500
ZNMH141	Zinc Nail-In	1/4 X 1 (Mushroom Head)	1"	1/4"	1/4"	7/8"	100	500
ZNMH14114	Zinc Nail-In	1/4 X 1 1/4 (Mushroom Head)	1-1/4"	1/4"	1/4"	1"	100	500
ZNMH14112	Zinc Nail-In	1/4 X 1 1/2 (Mushroom Head)	1-1/2"	1/4"	1/4"	1-1/4"	100	500
ZNMH142	Zinc Nail-In	1/4 X 2 (Mushroom Head)	2"	1/4"	1/4"	1-1/2"	100	500
ZNMH143	Zinc Nail-In	1/4 X 3 (Mushroom Head)	3"	1/4"	1/4"	2-1/2"	100	500

Part ID	Product Name	Description	Overall Length	Overall Diameter	ANSI Drill Diameter	Min. Embed	Box Quantity	Carton Quantity
ZNMHSS141	SS Nail-In	1/4 X 1 (Mushroom Head)	1"	1/4"	1/4"	7/8"	100	500
ZNMHSS14114	SS Nail-In	1/4 X 1 1/4 (Mushroom Head)	1-1/4"	1/4"	1/4"	1"	100	500
ZNMHSS14112	SS Nail-In	1/4 X 1 1/2 (Mushroom Head)	1-1/2"	1/4"	1/4"	1-1/4"	100	500
ZNMHSS142	SS Nail-In	1/4 X 2 (Mushroom Head)	2"	1/4"	1/4"	1-1/2"	100	500



# Removable Zinc Nail-in Anchors

Aerosmith®'s Removable Zinc Nail-In Anchor is a medium to light duty anchor whose body is made of zinc alloy and its screw made of carbon steel. Unlike the standard zinc nail-in, this product comes with a screw rather than a nail so that once installed, it can be removed. The product can be used in concrete, brick, block and stone and is easy to install. Pre-drill the same diameter hole as the anchor body, position fixture in place, tap anchor into pre-drilled hole. When flush, hammer the head of the screw into the body of the anchor. To remove, just back out the screw to release the expansion mechanism. This anchor should not be used in overhead applications.

## APPLICATIONS:

- Drywall track
- Light duty signage
- Brick ties
- Parapet flashing

## FEATURES & BENEFITS:

- Fast installation
- Nails available in stainless steel
- No special tools needed
- Can be used in a variety of base materials
- Flush appearance when properly set
- Available in removable version

## BASE MATERIAL:

- Concrete
- Brick
- Block
- Stone

## ANCHOR COMPONENT MATERIALS:

- Zinc Zamac Alloy (Body)
- Carbon Steel (Screws)

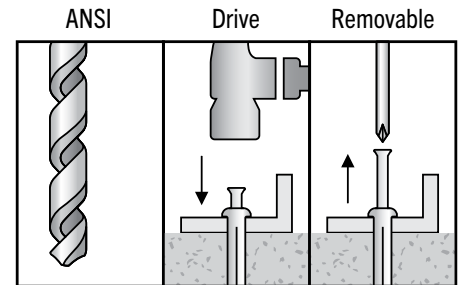

Part ID	Product Name	Description	Overall Length	Overall Diameter	ANSI Drill Diameter	Min. Embed	Box Quantity	Carton Quantity
ZNHS1434	Removable Zinc Nail-In	1/4 X 3/4"	3/4"	1/4"	1/4"	5/8"	100	500
ZNHS141	Removable Zinc Nail-In	1/4 X 1"	1"	1/4"	1/4"	7/8"	100	500
ZNHS14114	Removable Zinc Nail-In	1/4 X 1-1/4"	1-1/4"	1/4"	1/4"	1"	100	500
ZNHS14112	Removable Zinc Nail-In	1/4 X 1-1/2"	1-1/2"	1/4"	1/4"	1-1/4"	100	500
ZNHS142	Removable Zinc Nail-In	1/4 X 2"	2"	1/4"	1/4"	1-1/2"	100	500
ZNHS143	Removable Zinc Nail-In	1/4 X 3"	3"	1/4"	1/4"	2-1/2"	100	500



# Split Drive Anchor

Aerosmith®'s Split Drive anchor is a one piece, all steel mechanical anchor that can be used in concrete, brick, and stone. Its available in a 1/4 diameter, up to 4 inches in length. It comes with a flat head, aka counter sunk and is ideal for applications where the fastening needs to either be permanent or tamper proof. It also works extremely well in wood to concrete connections. Just drill a hole the same diameter as the anchor and hammer it through your fixture and into the base material. It is that simple.

## APPLICATIONS:

- Drywall track
- Light duty signage
- Brick ties
- Parapet flashing

## FEATURES & BENEFITS:

- Fast installation
- No special tools needed
- Can be used in a variety of base materials
- Flush appearance when properly set

## BASE MATERIAL:

- Concrete
- Brick
- Block
- Stone

## ANCHOR COMPONENT MATERIALS:

- Carbon Steel
- Heat Treated

Part ID	Product Name	ANSI Drill Diameter	Diameter	Min. Embed	Box Quantity	Carton Quantity
SDA142000	Split Drive Anchor 1/4" x 2" (Flathead)	2"	1/4"	1-1/8"	100	800
SDA143000	Split Drive Anchor 1/4" x 3" (Flathead)	3"	1/4"	1-1/8"	100	800
SDA144000	Split Drive Anchor 1/4" x 4" (Flathead)	4"	1/4"	1-1/8"	100	500



# **CAST IN PLACE ANCHORS**



# Blue Banger Hanger™ Steel Deck Insert

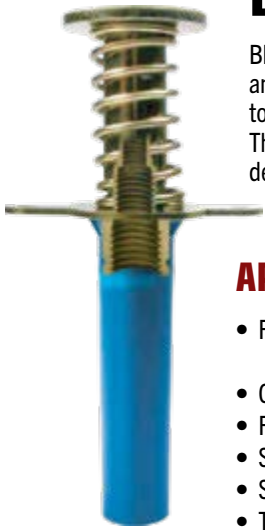

Blue Banger Hanger Steel Deck Inserts are installed prior to pouring concrete which reduces installation and material costs and increases strength values. The parts take multiple sizes of threaded rod, have a large flanged head, and a 3" plastic sleeve to help keep threads clean. An installation tool is also available to punch a hole through the metal deck for ease of installation. The parts are also seismically qualified for use in cracked concrete. Installation is quick and easy, punch hole through metal deck – insert blue banger hanger, apply pressure to head of anchor to lock in place and pour concrete.

## APPLICATIONS:

- For hanging threaded rod in overhead applications
- Cable trays
- Fire sprinkler pipes
- Suspended conduit
- Suspended ceiling and lighting
- Telecommunication installations
- Water pipes (plumbing)
- HVAC

## FEATURES & BENEFITS:

- The Steel Deck Inserts installed height of just 2 inches can be used through or between the ribs of the deck
- Patented grooved insert body prevents component separation even if the flute is broken off prior to pour
- Reduces inventory so three inserts can accommodate five threaded rod sizes
- Allows for threaded rod size changes after inserts are installed
- Internal threads eliminate the need and cost of couplings
- Keeps internal threads clean
- Extended length makes insert easy to locate even with fireproofing on deck underside
- Plastic sleeve provides guidance to align threaded rod with matching internal female threads
- Positions all inserts on the project at the same elevation to eliminate multiple all thread rod lengths and improve the accuracy of offsite prefabrication

## APPROVALS:

ICC-ES ESR-3599



All reports listed below are owned by Tomarco /ISAT Construction Supplies

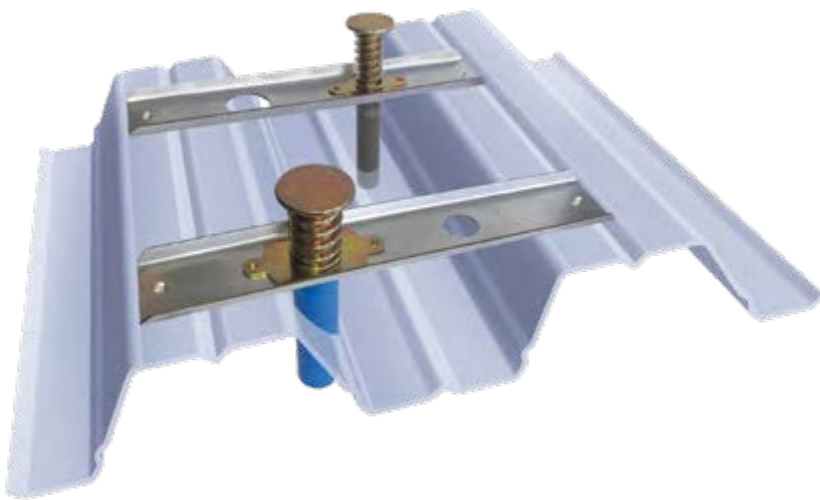

Drill hole in deck  
Insert Blue Banger Hanger w/ sleeve down  
Step on anchor to lock in place  
Insert threaded rod from underneath deck

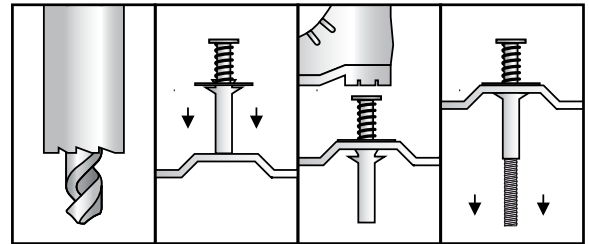

Part ID	Size	Box Quantity
HEA-SD1143812	1/4", 3/8", 1/2"	100
HEA-SD1381258	3/8", 1/2", 5/8"	50
HEA-SD15834	5/8", 3/4"	50
CEABBDP1 Install Tool	1/4" - 3/8"	1
CEABBDP2 Install Tool	3/8" - 5/8"	1
HEA-RDI-143812	Roof Deck Insert	1
HEA-FSBX	New Universal FSB Bracket	1
RDI-2	Roof Deck Insert 2	1
POLMKEY36	Tele. Keyless Chuck Poll 3 ft.-6ft.	1
CEA-SB4	Step Bit For SDI 3/16" - 7/8"	1





# Blue Banger Hanger™ Pour In Place (PIP) Pour-in-Place Insert for the attachment of Threaded Rod

Pour-in-Place Inserts are used on wood form poured decks and installed prior to pouring concrete which reduces installation and material costs. Blue Banger Hanger PIP's are easy to use just strike the top of the hanger and drive the three mounting nails into the forming material until the bottom of the hanger is flush with the plywood. The hanger should be sitting 90 degrees perpendicular to the forming material. Once concrete is hardened, and forms are stripped, strike the mounting nails to break them off, it's that simple.

## APPLICATIONS:

- For hanging threaded rod in overhead applications
- Cable trays
- Fire sprinkler pipes
- Suspended conduit
- Suspended ceiling and lighting
- Telecommunication installations
- Water pipes (plumbing)
- HVAC

## FEATURES & BENEFITS:

- Provides excellent shear values for overhead attachments
- Reduces inventory so three inserts can accommodate five threaded rod sizes
- Allows for threaded rod size changes after inserts are installed
- Internal threads eliminate the need and cost of couplings
- Blue plastic ring acts as insert locator when forms are removed
- Plastic ring creates countersunk recess to keep threads clean from pour residue



## APPROVALS:

ICC-ES ESR-3599



## NEW SLURRY SEAL:

- Slurry seal safeguards the internal threads from concrete during the pour
- Red, white and blue colored slurry seal labels identify the insert when used by multiple trades
- Does not catch rod threads or interfere with rod size changes
- Won't fall out like foam inserts

All reports listed below are owned by Tomarco /ISAT Construction Supplies

## MULTI-THREAD SUPPORT:

- Multi-thread inserts reduce inventory - Compare to similar products who have as many as five insert sizes, one for each size
- Easily change rod sizes after the install - Not possible with single size inserts
- Slurry seal does not interfere with rod size changes, products that are difficult to break plastic or foam inserts that tangle



Hammer PIP Anchor set in into wood deck wood form

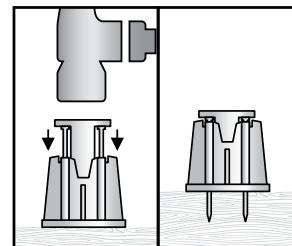

Part ID	Size	Box Quantity
HEA-PIP143812	1/4", 3/8", 1/2"	100
HEA-PIP381258	3/8", 1/2", 5/8"	50
HEA-PIP5834	5/8" - 3/4"	100
CEA-PIPInstallWide Tool	Pour-in-Place Tool Wide	1

CEA-PIPInstallWide Tool



# DRYWALL AND HOLLOW CAVITY ANCHORS

## Toggle Bolts



Aerosmith®'s Toggle Bolt is specifically designed to be used in drywall/wallboard and other hollow base materials where expansion anchors typically do not work or perform well. The toggle bolt is a two component system consisting of a machine bolt in either a round, mushroom, or flat head and a spring wing. Sizes range from 1/8" to 1/2" in diameter. A variety of different lengths can be used, depending on the application and thickness of the material, before entering the hollow cavity.

## Nylon & Zinc EZ Zip Drywall Anchors

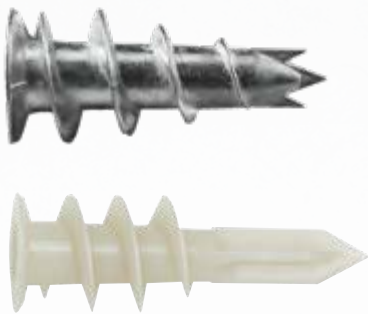

Aerosmith®'s EZ Zip Drywall/Wallboard Anchor is a one piece self-drilling anchor which is manufactured and available in both engineered nylon and zinc alloy. The EZ Zip is specifically designed for use in drywall/wallboard and can be used with either a number #6 or a number #8 sheet metal screw. Anchors can also be ordered with or without screws or in an easy to use EZ Zip kit version. It is intended for use in drywall/wallboard thicknesses of 3/8" to 1".

## Nylon Drywall Toggle

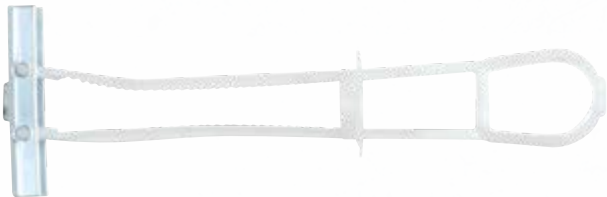

Aerosmith®'s Nylon Toggle is a one-piece pre-assembled anchor that can be used in hollow wallboard or hollow block applications. The anchor consists of a carbon steel wing and an engineered plastic strap. Simply fold the wing perpendicular to the strap, push wing through the proper pre-drilled hole, pull back on the strap, and slide the plastic disc against the front of the wall. Snap off the remaining nylon, put fixture in place and screw into the wing using a machine bolt of the proper diameter. By folding the wing perpendicular with the strap, this allows the anchor to be installed into smaller holes than conventional spring wing toggles. Nylon toggles are available in 3/16", 1/4", 3/8", and 1/2" diameters.

Mushroom Head



# Toggle Bolts

Aerosmith®'s Toggle Bolt is specifically designed to be used in drywall/wallboard and other hollow base materials where expansion anchors typically do not work or perform well. The toggle bolt is a two component system consisting of a machine bolt in either a round, mushroom, or flat head and a spring wing. Sizes range from 1/8" to 1/2" in diameter. A variety of different lengths can be used, depending on the application and thickness of the material, before entering the hollow cavity.

## APPLICATIONS:

- Attachment of insulation
- Suspended ceiling hangers
- Lighting
- TV brackets into hollow base materials
- Picture hanging
- Railings

## FEATURES & BENEFITS:

- Adjustable for various wall thicknesses
- Fast and easy installation and removal
- Available in a variety of head styles
- Product made from carbon steel
- Clamps the back of the base material providing resistance.

## BASE MATERIAL:

- Drywall
- Hollow block

Round Head



## ANCHOR COMPONENT MATERIALS:

Carbon Steel - Zinc plated

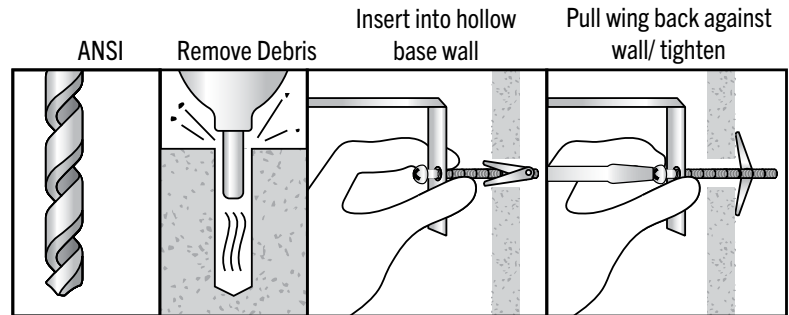

Flat Head



Wing



Part ID	Product Name	Description	Overall Length	Diameter	ANSI Drill Diameter	Box Quantity	Carton Quantity
TGMH182	Toggle Bolt Mushroom Head	1/8" X 2"	2"	1/8"	3/8"	50	500
TGMH183	Toggle Bolt Mushroom Head	1/8" X 3"	3"	1/8"	3/8"	50	500
TGMH184	Toggle Bolt Mushroom Head	1/8" X 4"	4"	1/8"	3/8"	50	500
TGMH3163	Toggle Bolt Mushroom Head	3/16" X 3"	3"	3/16"	1/2"	50	500
TGMH3164	Toggle Bolt Mushroom Head	3/16" X 4"	4"	3/16"	1/2"	50	500
TGMH143	Toggle Bolt Mushroom Head	1/4" X 3"	3"	1/4"	5/8"	50	500
TGMH144	Toggle Bolt Mushroom Head	1/4" X 4"	4"	1/4"	5/8"	50	500
TGRH182	Toggle Bolt Round Head	1/8" X 2"	2"	1/8"	3/8"	50	500
TGRH183	Toggle Bolt Round Head	1/8" X 3"	3"	1/8"	3/8"	50	500
TGRH184	Toggle Bolt Round Head	1/8" X 4"	4"	1/8"	3/8"	50	500
TGRH3163	Toggle Bolt Round Head	3/16" X 3"	3"	3/16"	1/2"	50	500
TGRH3164	Toggle Bolt Round Head	3/16" X 4"	4"	3/16"	1/2"	50	500
TGRH3165	Toggle Bolt Round Head	3/16" X 5"	5"	3/16"	1/2"	50	500
TGRH3166	Toggle Bolt Round Head	3/16" X 6"	6"	3/16"	1/2"	50	500
TGRH143	Toggle Bolt Round Head	1/4" X 3"	3"	1/4"	5/8"	50	500
TGRH144	Toggle Bolt Round Head	1/4" X 4"	4"	1/4"	5/8"	50	500
TGRH145	Toggle Bolt Round Head	1/4" X 5"	5"	1/4"	5/8"	50	500
TGRH146	Toggle Bolt Round Head	1/4" X 6"	6"	1/4"	5/8"	50	500
TGRH383	Toggle Bolt Round Head	3/8" X 3"	3"	3/8"	7/8"	25	250
TGRH384	Toggle Bolt Round Head	3/8" X 4"	4"	3/8"	7/8"	25	250
TGRH385	Toggle Bolt Round Head	3/8" X 5"	5"	3/8"	7/8"	25	125
TGRH386	Toggle Bolt Round Head	3/8" X 6"	6"	3/8"	7/8"	25	125
TGFH183	Toggle Bolt Flat Head	1/8" X 3"	3"	1/8"	3/8"	50	500
TGFH3164	Toggle Bolt Flat Head	3/16" X 4"	4"	3/16"	1/2"	50	500
TGFH143	Toggle Bolt Flat Head	1/4" X 3"	3"	1/4"	5/8"	50	500
TGFH144	Toggle Bolt Flat Head	1/4" X 4"	4"	1/4"	5/8"	50	500
TGW18	Toggle Wings	1/8"	N/A	N/A	3/8"	100	500
TGW316	Toggle Wings	3/16"	N/A	N/A	1/2"	100	1000
TGW14	Toggle Wings	1/4"	N/A	N/A	5/8"	100	1000
TGW38	Toggle Wings	3/8"	N/A	N/A	7/8"	50	500





# EZ Zip Drywall Anchors

Aerosmith®'s EZ Zip Drywall Anchor is a one-piece self-drilling anchor which is manufactured and available in both engineered nylon and zinc alloy. It is specifically designed for use in dry wall and can be used in wallboard from 3/8" to thickness. Both the nylon and zinc part can be used with a #6 or #8 screw.

## APPLICATIONS:

- Electrical fixtures
- Shelving
- Telephone systems
- Curtain poles
- Interior finishing
- Miscellaneous hardware

## FEATURES & BENEFITS:

- Fully removable
- No requirement for pre-drilling
- Accurate fixing with tooth design
- Accurate fixing with point design in drywall

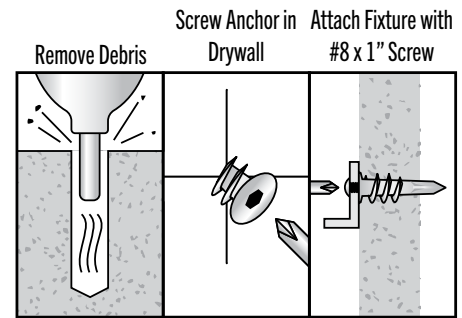

## ANCHOR COMPONENT MATERIALS:

- Engineered Nylon
- Zinc Alloy

## BASE MATERIAL:

- Drywall / Wallboard

Part ID	Description	Wall Thickness	Screw Size	Box Quantity	Carton Quantity
ZPZ381	Zinc Drywall Anchor 3/8" to 1" w/Screw	3/8" - 1"	#8x1"	100	1000
ZPZ381NS	Zinc Drywall Anchor 3/8" to 1" w/o Screw	3/8" - 1"	#8x1"	100	1000
ZPZ381NSB	Zinc Drywall Anchor 3/8" to 1" w/o Screw	3/8" - 1"	#8x1"	1000	1000
ZPZ381K	Zinc Drywall Anchor 3/8" to 1" Kit	3/8" - 1"	#8x1"	1	10
ZPN381	Nylon Drywall Anchor 3/8" to 1" w/ Screw	3/8" to 1"	#8x1"	100	1000
ZPN381NS	Nylon Drywall Anchor 3/8" to 1" w/o Screw	3/8" to 1"	#8x1"	100	1000
ZPN381B	Nylon Drywall Anchor 3/8" to 1" Bulk	3/8" to 1"	#8x1"	1000	1000
ZPN381K	Nylon Drywall Anchor 3/8" to 1" Kit	3/8" to 1"	#8x1"	1	10



# Nylon Drywall Toggle

Aerosmith®'s Nylon Toggle is a one-piece pre-assembled anchor that can be used in hollow wallboard or hollow block applications. The anchor consists of a carbon steel wing and an engineered plastic strap. Simply fold the wing perpendicular to the strap, push wing through the proper pre-drilled hole, pull back on the strap, and slide the plastic disc against the front of the wall. Snap off the remaining nylon, put fixture in place and screw into the wing using a machine bolt of the proper diameter. By folding the wing perpendicular with the strap, this allows the anchor to be installed into smaller holes than conventional spring wing toggles. Nylon toggles are available in 3/16", 1/4", 3/8", and 1/2" diameters.

## APPLICATIONS: FEATURES & BENEFITS:

- Towel bars
- Kitchen cabinets
- Bathroom accessories
- Electrical boxes
- Pictures
- Mirrors
- Handrails
- Signage
- Fully adjustable for different wall thickness
- Quick and easy installation
- Available in 4 diameters
- Wing clamps behind wall
- Can be used in wall thickness up to 2-1/2"

## BASE MATERIAL:

- Drywall
- Hollow block

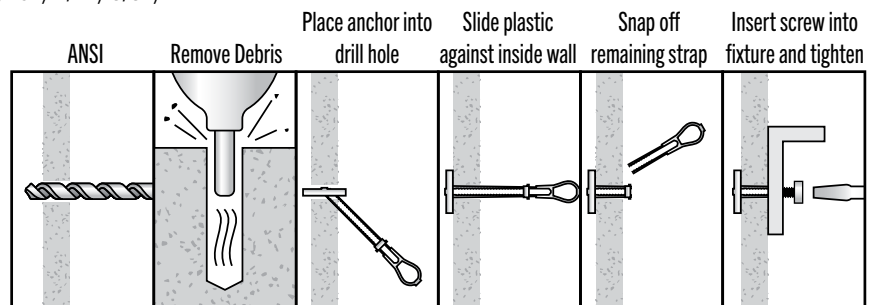

## ANCHOR COMPONENT MATERIALS:

Engineered Plastic with a Carbon Steel Wing

Part ID	Description	ANSI Drill Diameter	Box Quantity	Carton Quantity
STG316	3/16" x 4"	1/2"	50	300
STG14	1/4" x 4"	1/2"	50	300
STG38	3/8" x 4"	3/4"	25	150
STG12	1/2" x 4"	3/4"	25	150

A close-up photograph showing a person's hand holding a metal bolt and nut. The bolt is being inserted into a hole in a concrete surface. A grey adhesive is visible around the base of the bolt. In the background, a person's leg and a blue object are partially visible.

# ADHESIVE ANCHORING



# Aerosmith® Sure-Set® Epoxy

At Aerosmith® Fastening Systems, your health and safety on the construction site, is job one. That's why we ensure that all the adhesives we sell carry the highly recognized ICC-ES and IAPMO Certified Approvals. What this means is that these products have gone through extensive and rigorous testing to not only ensure product quality, but more importantly when used appropriately, perform as intended with your safety and the safety of others at the forefront.

## PRODUCT INFORMATION:

Sure-Set® Pure Epoxy is a two-component 1:1 ratio pure epoxy bonded anchoring system for use in cracked and uncracked concrete under normal, as well as, seismic conditions (seismic category C1). Designed for the most demanding structural applications and rebar connections, Sure-Set® Epoxy, offers high load capacities when used in conjunction with threaded rod, rebar or steel dowels. The Aerosmith® Adhesive System includes a two part adhesive packaged within plastic cartridges, a mixing nozzle is also packaged in with each tube to ensure proper mixing occurs. Dispensing tools and hole cleaning equipment is also available to ensure proper installation. Sure Set® Epoxy is a 100% epoxy resin that has been formulated with no MXDA, Phenol, N-Methyl Pyrrolidone, Bisphenol A, Phthalates or VOCs. This formulation exhibits minimal shrinkage which makes it ideal for use with oversized holes. In addition, the extended gel time also allows convenient use in deep holes and when used in high ambient temperatures.

## APPLICATIONS:

- Structural applications in cracked and uncracked concrete
- Building facades
- Post installed rebar connections
- Crash barriers
- The attachment of structural steel
- Railings
- Signage
- Rebar doweling
- Sill plate attachments: suitable for horizontal, vertical and overhead anchoring applications.

## IMPORTANT INFORMATION:

- Can be used with threaded rod diameter range 3/8" – 1-1/4"
- Can be used with reinforcing rebar #3, #4, #5, #6, #7, #8 and #10
- Storage life is two years (24 Months) in dry conditions, when kept at temperatures ranging from 41°F to 95°F
- High load capacities (see ICC-ESR 4412) for performance data
- Easy access when using designed nozzle into pre-drilled holes
- Can be used in wet and or dry environments
- Sure-Set™ epoxy enables the user more working time before adhesive set up
- High bond strengths when fully cured

## BASE MATERIALS:

- Concrete
- Hard natural stone
- Solid rock
- Solid masonry

## APPROVALS AND LISTING:

ICC-ES ESR-4412 Cracked and Uncracked Concrete Category 1

Code Compliant IBC Listed (International Building Code)

Code Compliant IRC Listed (International Residential Code)

Code Compliant FBC Listed (Florida Building Code)

Code Compliant FRC Listed (Florida Residential Code)

Code Compliant COLA Listed (City of Los Angeles)

Tested in accordance with AC308 and AC58 for use in structural concrete and masonry



Part ID	Product	Cartridge size	Carton Quantity
PE-10	Sure-Set® PE-10	10 oz (8.5 fluid ounces)	12
PE-21	Sure-Set® PE-21	21 oz (21 fluid ounces)	12

## INSTALLATION INSTRUCTIONS WHEN USED IN SOLID BASE MATERIALS

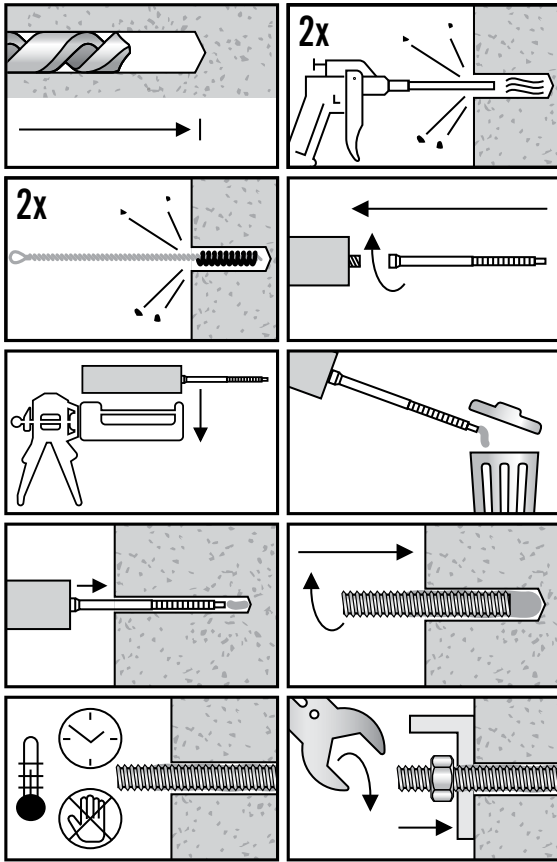

## INSTALLATION INSTRUCTIONS WHEN USED IN OVERHEAD APPLICATIONS

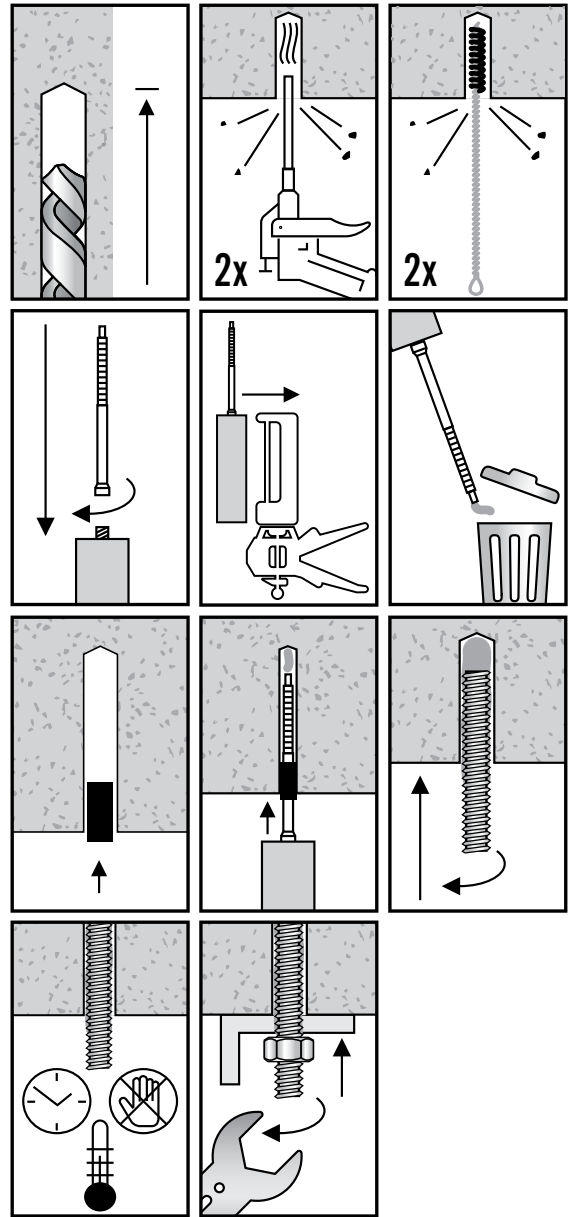

# Aerosmith® Sure-Set CIC-1200A (Acrylic) - 11 ounces

At Aerosmith® Fastening Systems, your health and safety on the construction site, is job one. That's why we ensure that all the adhesives we sell carry the highly recognized ICC-ES and IAPMO Certified Approvals. What this means is that these products have gone through extensive and rigorous testing to not only ensure product quality, but more importantly when used appropriately, perform as intended with your safety and the safety of others at the forefront.

With that in mind, Aerosmith® Fastening Systems is pleased to announce its new Sure-Set® CIC-1200A (Acrylic), available in a 11 ounce cartridge size.



## PRODUCT INFORMATION:

The Sure-Set® CIC-1200A is the most environmentally friendly resin system within our range, while exhibiting outstanding performance in concrete, masonry, and other base materials. It is ideally suited for high load/heavy duty structural anchoring applications. It can be used with threaded rod, reinforcing bar, and steel dowels in solid base materials or in conjunction with an Aerosmith® screen tube for hollow based anchoring applications.

It is free of styrene's, the Sure-Set® CIC-1200A formulation has a very low odor and is well suited for use indoors and in confined places. It also has a very low VOC content and no hazard symbols are required to be displayed on the product label, nor is it hazardous for any mode of transportation.

The Sure-Set® CIC-1200A has not only been evaluated by IAPMO, it has also been fire tested and has received fire resistance classification F120 (for use with threaded bars) & F240 (for use with rebars). For those operating in markets where American building codes are recognized, CIC-1200A can offer Evaluation Service Report from IAPMO ER-668.

## APPLICATIONS:

- For use in structural applications in cracked and uncracked concrete (category 1) for threaded rod, reinforcing bars, & steel dowels
- Suspended ventilation systems
- Safety barriers
- Machinery & heavy machinery
- Rolling cranes
- Structural steel to concrete applications

## IMPORTANT INFORMATION:

- Is approved and listed for cracked and uncracked concrete category 1
- Can be used in low and high strength concrete
- Product is styrene free
- Can be used in dry and wet environments
- Can be used overhead with epoxy resin stoppers
- Product has been seismic tested
- Product is fire resistant
- Product has a low odor formulation and can be use in both indoor and outdoor applications
- Product mixes through dispensing nozzle, no premixing required

## BASE MATERIALS:

- Concrete
- Solid & hollow masonry (If using in hollow base material applications a stainless steel or nylon screen tube is needed to encapsulate the adhesive)
- Hard natural stone
- Solid rock
- Voided stone or rock

## APPROVALS AND LISTING:

IAPMO ER-668 For use in Cracked and Uncracked Concrete category 1

IBC Listed (International Building Code)

IRC Listed (International Residential Code)

COLA Listed (City of Los Angeles)

Tested in accordance with AC308 and AC58 for use in structural concrete and masonry



Part ID	Product	Cartridge size	Carton Quantity
CIC-1200	Sure-Set® CIC-1200	11 oz (10.5 fluid ounces)	12
ACR-28	Sure-Set® ACR-28	28 oz (27.9 fluid ounces)	6

## INSTALLATION INSTRUCTIONS WHEN USED IN SOLID BASE MATERIALS

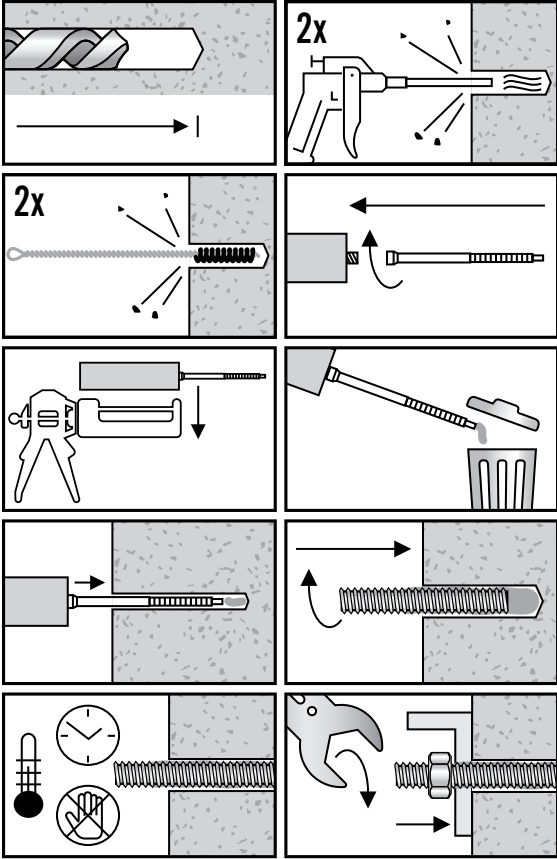

## INSTALLATION INSTRUCTIONS WHEN USED IN OVERHEAD APPLICATIONS

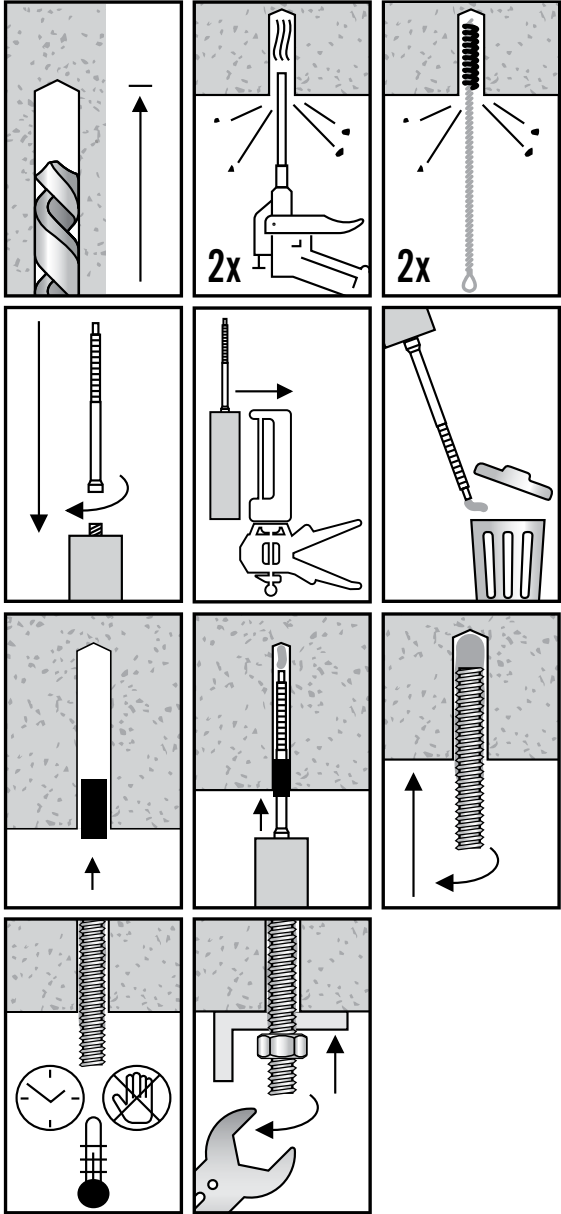

# SURE-SET® PURE EPOXY ACCESSORIES

## HOLE CLEANING BRUSHES



Part ID	Description	Box Quantity
716BRUSH	3/8 Brush - 7/16 Hole	1
916BRUSH	1/2 Brush - 9/16 Hole	1
1116BRUSH	5/8 Brush - 11/16 Hole	1
78BRUSH	3/4 Brush - 7/8 Hole	1
1BRUSH	7/8 Brush - 1 Hole	1
118BRUSH	1 Brush - 1 1/8 Hole	1
138BRUSH	1 1/4 Brush - 1 3/8 Hole	1
112BRUSH	1 3/8 Brush - 1 1/2 Hole	1

## PURE EPOXY MIXING NOZZLES



Part ID	Description	Bag Quantity	Carton Quantity
MN1021	Mixing Nozzle for 10 and 21 ounce Pure Epoxy	5	25
MN1021L	Mixing Nozzle for 10 and 21 ounce Pure Epoxy (Deep Holes)	5	25

## EXTENSION TUBES

Part ID	Description	Box Quantity	Carton Quantity
ET38	3/8 inch Extension Tubing	1	12
ET916	9/16 inch Extension Tubing	1	12

## DISPENSING TOOLS



Part ID	Description	Box Quantity
DT10	Sure-Set Manual Dispensing Tool 10 oz	1
DT22	Sure-Set Manual Dispensing Tool 22 oz	1
DTHD10	Sure-Set Heavy Duty Dispensing Tool 10 oz	1
DTHD22	Sure-Set Heavy Duty Dispensing Tool 22 oz	1

## SCREEN TUBES - STAINLESS STEEL



Part ID	Description	Box Quantity
386SCREEN	3/8 x 6 300 Stainless Steel Screen	25
3810SCREEN	3/8 x 10 300 Stainless Steel Screen	25
126SCREEN	1/2 x 6 300 Stainless Steel Screen	25
1210SCREEN	1/2 x 10 300 Stainless Steel Screen	25
586SCREEN	5/8 x 6 300 Stainless Steel Screen	10
346SCREEN	3/4 x 6 300 Stainless Steel Screen	20

## EPOXY STOPPERS



Part ID	Description	Box Quantity	Carton Quantity
ES18	18MM Epoxy Stoppers overhead	10	100
ES22	22MM Epoxy Stoppers overhead	10	100
ES30	30MM Epoxy Stoppers overhead	10	100

# SURE-SET® EPOXY ACRYLATE (ACRYLIC) ACCESSORIES

## HOLE CLEANING BRUSHES



Part ID	Description	Box Quantity
716BRUSH	3/8 Brush - 7/16 Hole	1
916BRUSH	1/2 Brush - 9/16 Hole	1
1116BRUSH	5/8 Brush - 11/16 Hole	1
78BRUSH	3/4 Brush - 7/8 Hole	1
1BRUSH	7/8 Brush - 1 Hole	1
118BRUSH	1 Brush - 1 1/8 Hole	1
138BRUSH	1 1/4 Brush - 1 3/8 Hole	1
112BRUSH	1 3/8 Brush - 1 1/2 Hole	1

## ACRYLIC MIXING NOZZLES

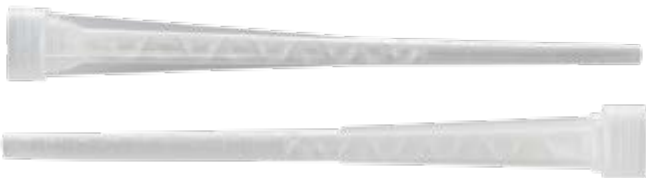

Part ID	Description	Bag Quantity	Carton Quantity
MNA10	Mixing nozzle for 10 Ounce Acrylic Adhesive	5	25
MNA28	Mixing nozzle for 28 Ounce Acrylic Adhesive	5	25

## EXTENSION TUBES

Part ID	Description	Box Quantity	Carton Quantity
ET38	3/8 inch Extension Tubing	1	12
ET916	9/16 inch Extension Tubing	1	12

## DISPENSING TOOLS



Part ID	Description	Box Quantity
DT10	Sure-Set Manual Dispensing Tool 10 oz	1
DTHD10	Sure-Set Heavy Duty Dispensing Tool 10 oz	1
DT28	Sure-Set HD Manual Dispensing Tool 28 oz	1

## SCREEN TUBES - STAINLESS STEEL



Part ID	Description	Box Quantity
386SCREEN	3/8 x 6 300 Stainless Steel Screen	25
3810SCREEN	3/8 x 10 300 Stainless Steel Screen	25
126SCREEN	1/2 x 6 300 Stainless Steel Screen	25
1210SCREEN	1/2 x 10 300 Stainless Steel Screen	25
586SCREEN	5/8 x 6 300 Stainless Steel Screen	10
346SCREEN	3/4 x 6 300 Stainless Steel Screen	20

## EPOXY STOPPERS



Part ID	Description	Box Quantity	Carton Quantity
ES18	18MM Epoxy Stoppers overhead	10	100
ES22	22MM Epoxy Stoppers overhead	10	100
ES30	30MM Epoxy Stoppers overhead	10	100





## CRACKED CONCRETE SOLUTIONS BY AEROSMITH



**Sure-Bolt<sup>®</sup> ICC-ES Listed #4414 Category 1**

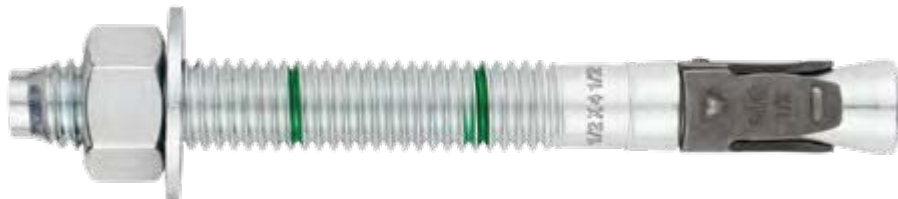

**Sure Wedge<sup>®</sup> ICC-ES Listed #4413 Category 1**



**Blue Banger Hanger Pour In Place (PIP)  
ICC-ES #3599 Category 1**

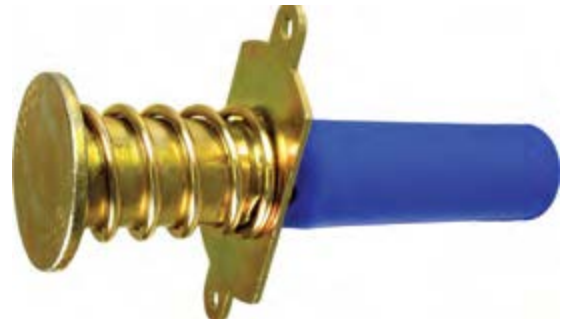

**Blue Banger Hanger Steel Deck Insert  
ICC-ES #3599 Category 1**



**Sure-Set<sup>®</sup> Acrylic Adhesive  
CIC1200A Iampo #668 Category 1**



**Sure-Set<sup>®</sup> Pure Epoxy  
PE-21 ICC-ES #4412 Category 1**



## **Introducing The New and Improved ACR-10 Cartridge System.** **Acrylic CIC-1200A The new “Capsule in Cartridge” System**

### **CAPSULE IN CARTRIDGE (CIC) VS THE PEELER DESIGN CARTRIDGE (PLR)**

The CIC Cartridge Design is a high strength, two chamber foil capsule (Bag) that easily compresses and compacts as you dispense the product.

The PLR Cartridge Design relies on cutting blades in the piston that are forced to cut and separate the central plastic tube that holds part B of the product.

**CRACKED CONCRETE APPROVED,  
CATEGORY 1, IAPMO ER-668**

**NEW!**  
**CIC CARTRIDGE CUT-AWAY**



### **Features and Benefits of the CIC Capsule in Cartridge System.**

**More Product:** Larger 11 ounce cartridge versus 10 Ounce Peeler. Gives you a full extra ounce at no additional cost.

**Easier Extrusion:** CIC needs less force to dispense with no cutting of internal plastic components required. Dispenses faster.

**Less Waste:** The capsule fully compacts and extrudes all of the product.

**No Leakage:** Innovative CIC cartridge prevents piston leakage from the back of the cartridge.

**Less Plastic:** Significantly reduces the plastic content making it more sustainable.

**Longer Shelf Life:** CIC gives you 20 months of Shelf life versus 14 Months for the Peeler.



## Aerosmith® Headquarters and Direct Fastening Warehouse Locations:

5621 Dividend Road,  
Indianapolis, Indiana 46241  
Phone: Toll Free 1-800-528-8183  
www.aerosmithfastening.com  
Contact: Ashley Valley/Haley Helms  
Phone: Toll Free 1-844-373-2666  
Email: AValley@aerosmithfastening.com  
Email: HHelms@Aerosmithfastening.com

## Mechanical and Adhesive Anchoring Warehouse locations:

### Aerosmith® Fastening Systems Florida

(Full Stocking Warehouse)  
South East Branch Location  
2915 Bush Drive  
Melbourne, Florida 32935  
Contact: Isaiah Johnson  
Phone: 321-242-8485  
Email: isaiah@laddassociatesinc.com

### Aerosmith® Fastening Systems Indianapolis

(Full Stocking Warehouse)  
MDC Marketing  
3313 S. Arlington Ave #1  
Indianapolis, Indiana 46203  
Contact: Brian/Brenda and Michael Berry Phone:  
317-782-8001  
Fax: 317-782-8002  
Email: mdcmarketing@sbcglobal.net

### Aerosmith® Fastening Systems New Jersey

(Full Stocking Warehouse)  
A&N Sales  
70 Sewell Street  
Glassboro, NJ 08028  
Contact: Nick and Sam Casale Phone:  
610-461-2200  
Fax: 610-461-2201  
Email: Info@ansales.com

### Aerosmith® Fastening Systems Pittsburgh

((Ships from Glassboro, NJ)  
Power Marketing and Sales  
1360 Island Ave,  
McKees Rock, PA 15136  
Contact: Mark Schreiner and Bill Dugan  
Phone: 412-771-3010  
Fax: 412-771-9858  
Email: Powermarketing1@verizon.net

### Aerosmith® Fastening Systems Southeast

(Ships from Glassboro, NJ)  
Baker Associates  
104 Chipendale Square  
Kingsport, TN 37660  
Contact: Lon Baker  
Phone: 336-549-1908  
Email: Lbaker1974@aol.com

# aerosmith®

fastening systems



**Aerosmith Direct Fastening**  
**Toll Free 800-528-8183**

**[Customer\\_Service@aerosmithfastening.com](mailto:Customer_Service@aerosmithfastening.com)**

**5621 Dividend Road • Indianapolis, Indiana 46241**

**[www.aerosmithfastening.com](http://www.aerosmithfastening.com)**

**Aerosmith® Anchoring**  
**(844)-373-2666**

revised date 3/15/2024