



aerosmith[®]
fastening systems



BUYERS GUIDE

MECHANICAL AND ADHESIVE ANCHORING



INDEX

Heavy Duty Mechanical Anchors

Sure-Wedge® Carbon Steel Wedge Anchors (ICC-ES Listed for Cracked and Uncracked Concrete Category 1) Report # ESR-4413	39
Carbon Steel Wedge Anchors	40
304 Stainless Steel Wedge Anchors	41
316 Stainless Steel Wedge Anchors	42
Sure-Bolt® Concrete Screw Bolts (ICC-ES Listed for Cracked and Uncracked Concrete Category 1) Report # ESR-4414	43
Sure-Bolt® Extreme Concrete Screw Bolts (ICC-ES Listed for Cracked and Uncracked Concrete Category 1) Report # ESR-4414	44
Concrete Bolts	44
Sleeve Anchors Carbon Steel	45
Sleeve Anchors 304 Stainless Steel	46
Caulking Anchors	46
Drop-in Anchors (Carbon Steel, 304 and 316 SS, Coil Thread, Shallow Embedment)	46
Hollow Block Anchors	47
Dual Machine Bolt Anchors	48
Machine Bolt Anchors	48
Sure-Lag	49
SDS-Plus Carbide Drill Bit (4 Cutter)	50

Medium to Light Duty Mechanical Anchors

Strike Anchors	52
Sure-Con® Concrete Screws Blue and White	53
Sure-Con® 410 Stainless Steel	54
Sure-Con® Concrete Screw Bits	55
Hangerz	56
Sockets	57
Zinc Nail-in Anchors	58
Zinc Removable Nail-in Anchors and Split Drive Anchor	59
Split Drive Anchor	59

Cast in Place Anchors

Blue Banger Hangers™	61-62
--------------------------------	-------

Drywall and Hollow Cavity Anchors

Plastic Anchor Kits	63
Toggle Bolts and Wings	64
Nylon & Zinc Drywall Anchors	65
Nylon Drywall Toggles	65

Adhesive Anchoring

Sure-Set® PE10/21-Plus+ (ICC-ES Listed for Cracked and Uncracked Concrete Category1) Report # ESR-5901	67
Sure-Set® ACR10/28-Plus+(ICC-ES Listed for Cracked and Uncracked Concrete Category1) Report # ESR-5945.	69

HEAVY DUTY MECHANICAL EXPANSION ANCHORS

Sure-Wedge® ICC-ES Listed



Aerosmith®'s Sure Wedge® is a torque- controlled, mechanical expansion anchor, consisting of an anchor body, expansion clip, nut and washer. The anchor body has a tapered mandrel formed on the installed end of the anchor and a threaded section at the opposite end. Suitable base materials include, normal weight concrete and lightweight concrete. The anchors are used to resist static; wind and seismic tension and shear loads in cracked and uncracked normal weight and lightweight concrete having a specific compressive strength of 2500 PSI to 8500 PSI. The anchor is manufactured with a zinc plated carbon steel body and sherardized clip that wraps around the mandrel, rotating freely before installation.

Wedge Anchor Carbon Steel



Aerosmith®'s Wedge Anchor is a threaded, torque-controlled, carbon steel wedge expansion anchor. It is designed for consistent performance in solid concrete or grout filled concrete masonry. The anchor is made of a carbon steel body and expansion clip. Anchor is driven into pre-drilled hole which is the same diameter of the anchor body. Threaded studs are then set by tightening the nut to the required torque value for optimum performance.

Wedge Anchor 304 SS



Aerosmith®'s Wedge Anchor type 304 Stainless Steel is a threaded, torque-controlled, stainless steel wedge expansion anchor. It is designed for consistent performance in normal and lightweight concrete. The anchor body, clip, nut and washer are made of 304 Stainless Steel. Drill same diameter hole into concrete as the anchor body and drive anchor through fixture into pre-drilled hole, tighten to required torque value.

Wedge Anchor 316 SS



Aerosmith®'s Wedge Anchor grade 316 Stainless Steel is a threaded, torque-controlled, stainless steel wedge expansion anchor and is designed for consistent performance in concrete. The anchor, clip, nut and washer are made of Type 316 Stainless Steel. Drill same diameter hole into concrete as the anchor body and drive anchor through fixture into pre-drilled hole.

Concrete-Bolt Anchors



The Aerosmith® Concrete-Bolt is a one-piece, heavy duty screw anchor with a finished hex head and is manufactured from carbon steel and is heat treated. The Concrete-Bolt is available in a variety of sizes from 3/8" to 5/8" inches. The hex head diameter is larger than the diameter of the anchor and is formed with serrations on the underside. The anchor can be installed in a pre-drilled hole with a powered impact wrench or a torque wrench. Anchor threads cut into concrete on the sides of the hole and interlock with the base material during the installation. Suitable base materials include normal and lightweight concrete. It is designed for consistent and reliable performance in uncracked concrete.

Sure-Bolt® ICC-ES Listed



Aerosmith®'s Sure Bolt® is a one-piece, heavy duty screw anchor with a finished hex head. It is manufactured from carbon steel and is heat treated. The Sure-Bolt® is available in a variety of sizes from 1/4 to 3/4 inch. The hex head diameter is larger than the diameter of the anchor and is formed with serrations on the underside. The anchor can be installed in a pre-drilled hole with a powered impact wrench or a torque wrench. The threads cut into concrete on the sides of the hole and interlock with the base material during the installation. Suitable base materials include normal and lightweight concrete. It is designed for consistent and reliable performance in cracked and uncracked concrete.

Sure-Bolt® Extreme Atlantis Coating ICC-ES Listed



The Sure-Bolt® Extreme is a one-piece heavy-duty Hex Head screw anchor, comprised of a Carbon steel body that is heat treated and then coated for corrosion resistance. It is available in 3/8, 1/2 and 5/8 diameters up to 6" in length. Just drill the same diameter hole as the anchor body and run the part in with either a corded/cordless impact wrench or a regular hand socket. Anchor threads cut into the concrete on the sides of the hole and interlock with the base material during installation. Suitable base materials include normal and lightweight concrete, brick, and grout filled block. The anchor has also been evaluated by ICC-ES for consistent use and reliability in Cracked and Uncracked concrete, category 1.

Sleeve Anchor Carbon Steel



Aerosmith®'s Sleeve Anchor is an all-steel pre-assembled anchor that can be used in a variety of solid base materials. Most popular base materials include concrete and masonry. They are available in multiple head styles, such as, hex nut, acorn nut and flat head to give you the finished appearance for your specific application. Simply drill the same diameter hole as the anchor and install anchor through fixture and then tighten to required torque specification.

HEAVY DUTY MECHANICAL ANCHORS (CONTINUED)

304 Stainless Steel Sleeve Anchor



The Aerosmith® 304 Stainless steel sleeve anchor is a preassembled expansion anchor that can be used in a variety of base materials which include, normal weight concrete, brick, and grout filled block. This anchor is available in both 3/8 and 1/2 diameters and comes with either an acorn nut or finished hex nut. Great for both internal and external applications where corrosion may be of concern. Simply drill the same size hole as the anchor diameter using a carbide drill bit and tap the anchor through your fixture and tighten to the required torque value. As you tighten the nut, the bolt pulls through the sleeve creating expansion.

Drop-ins

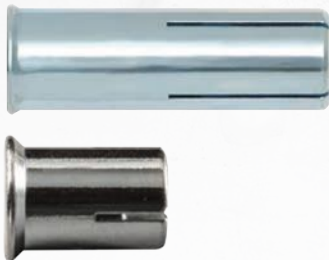

Aerosmith®'s Drop-in is a machine type bolt anchor available in 304 and 316 SS as well as carbon steel. The body is internally threaded for use in flush mount applications and solid base materials. Aerosmith® also offers a coil thread version for concrete forming applications available in both 1/2" and 3/4" diameters. A shallow embedment drop-in is also available which is made from carbon steel and can be used in solid concrete, hollow concrete, plank, hardstone and solid brick. Typical applications include hanging threaded rod overhead. Installation is easy, pre-drill a hole using the proper diameter for the anchor, tap anchor into pre-drilled hole until flush with base material. Use the appropriate setting tool to properly set the anchor and hammer the back of the setting tool until neck is flush with the top of the anchor. Put fixture in place and insert the machine bolt and tighten to the required torque. If using overhead, insert threaded rod to the minimal thread engagement which should be equal to the nominal diameter of the threaded insert. This product can be used in overhead applications.

Dual Machine Bolt Anchors



Aerosmith®'s Dual Machine Bolt Anchors can be used in solid concrete, brick, block and stone. The Dual Machine Bolt Anchors is made of die cast Zamac alloy and is corrosive resistant. Although the product can be used in many base materials it is sometimes used in questionable materials because it expands against the concrete at two points. Sizes are available from 1/4" to 3/4" diameters. Drill the proper diameter hole to the specified embedment, tap anchor into pre-drilled hole until flush. Put fixture in place and insert machine bolt.

Machine Bolt Anchors



Aerosmith®'s Machine Bolt Anchors can be used in concrete, block, brick and stone. The anchor consists of a set of expansion shields and an expander cone. The product is manufactured from zinc alloy. As the anchor is tightened, the cone gets drawn into the expansion shield which compresses them against the base material. This product is not recommended in overhead applications.

Sure-Lag



Aerosmith®'s Sure-Lag can be used to anchor into a variety of base materials such as concrete, brick and grout filled block. Although best suited for light to medium duty fastening, Sure-Lag anchors are available in 1/4", 5/16", 3/8", 1/2", 5/8" diameters, and are available in both short and long versions. The short version is typically used on harder base materials while the longer Sure-Lag are typically used on softer base materials where more embedment is required. Sure-Lags are made from zinc which enables them to be used in many different environmental conditions. To set, drill the proper size hole, tap Sure-Lag into the base material, put fixture in place and thread Lag screw into the lag shield until tight. The fixture is removable because the Sure-Lag anchor remains in the hole and only the lag screw can be unscrewed and removed. Not recommended for overhead applications.

Caulking Anchor



Aerosmith®'s Caulking Anchor is an internally threaded part whose sleeve is made of Zamac alloy. This anchor comes preassembled and can be used in concrete, brick, block and stone. Pre-drill the proper hole diameter and length, tap anchor into pre-drilled hole and properly set using the proper Aerosmith® caulking setting tool. Once properly set, put fixture in place and use the required machine bolt for proper attachment. This anchor can also be used in normal weight concrete, grout filled concrete, masonry (CMU) brick and stone. This anchor is not recommended for overhead applications.

Sure-Wedge®

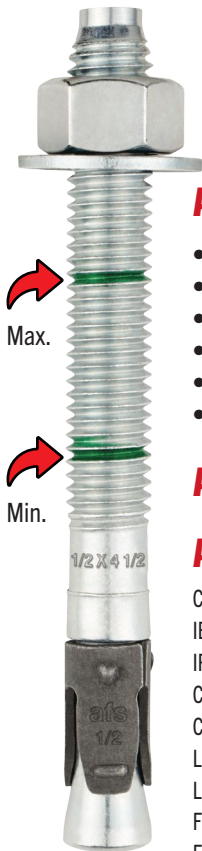

Suitable for installation in **CRACKED CONCRETE, UNCRACKED CONCRETE, REINFORCED CONCRETE & STONE.**

Aerosmith®'s Sure Wedge® are torque- controlled, mechanical expansion anchors consisting of an anchor body, expansion clip, nut and washer. The anchor body has a tapered mandrel formed on the installed end of the anchor and a threaded section at the opposite end. Suitable base materials include, normal weight concrete and lightweight concrete. The anchors are used to resist static; wind and seismic tension and shear loads in cracked and uncracked normal weight and lightweight concrete having a specific compressive strength of 2500 PSI to 8500 PSI. The anchor is manufactured with a zinc plated carbon steel body and sherardized clip that wraps ESR-4413 around the mandrel, rotating freely before installation.

APPLICATIONS:

- Barriers
- Railings
- Warehouse racking
- Conveyor systems
- Machinery
- Signage
- Fence posts
- Shelving
- Windows
- Overhead doors
- Electrical pipes
- Light fixtures

FEATURES & BENEFITS:

- Consistent performance in all types of concrete
- Drill size same as anchor size
- Easy and simple installation
- One piece design
- Comes complete with nuts and washers

BASE MATERIAL:

- Solid concrete
- Grout-filled masonry
- Hard stone

ANCHOR COMPONENT MATERIALS: Carbon Steel Zinc Plated (body, nut, washer and expansion clip)

APPROVALS:

Category 1 Cracked & Uncracked Concrete ICC-ES ESR-4413
 IBC Listed 2006, 2009, 2012, 2015, 2018, 2021
 IRC Listed 2006, 2009, 2012, 2015, 2018, 2021
 CBC 2019 Listed
 CRC 2019 Listed
 LABC 2020 Listed
 LARC 2020 Listed
 FBC 2020 Listed
 FRC 2020 Listed

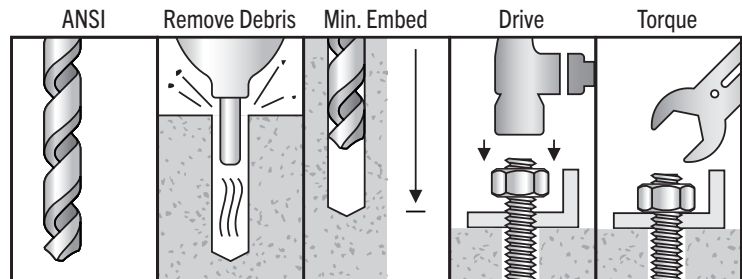

Part ID	Description	Overall Length	Diameter	Drill Diameter	Min. Embed	Max. Torque	Box Quantity	Carton Quantity
WA14134CC	Wedge Anchor Zinc ICC 1/4" X 1-3/4"	1-3/4"	1/4"	1/4"	1-1/2"	4 ft lbs	100	800
WA14214CC	Wedge Anchor Zinc ICC 1/4" X 2-1/4"	2-1/4"	1/4"	1/4"	2"	4 ft lbs	100	800
WA14314CC*	Wedge Anchor Zinc ICC 1/4" X 3 1/4"	3-1/4"	1/4"	1/4"	2"	4 ft lbs	100	800
WA38214CC*	Wedge Anchor Zinc ICC 3/8" X 2-1/4"	2-1/4"	3/8"	3/8"	2-1/3"	30 ft lbs	50	400
WA38234CC*	Wedge Anchor Zinc ICC 3/8" X 2-3/4"	2-3/4"	3/8"	3/8"	2-1/3"	30 ft lbs	50	400
WA38300CC	Wedge Anchor Zinc ICC 3/8" X 3"	3"	3/8"	3/8"	2-1/3"	30 ft lbs	50	200
WA38312CC	Wedge Anchor Zinc ICC 3/8" X 3-1/2"	3-1/2"	3/8"	3/8"	2-1/3"	30 ft lbs	50	200
WA38334CC	Wedge Anchor Zinc ICC 3/8" X 3-3/4"	3-3/4"	3/8"	3/8"	2-1/3"	30 ft lbs	50	200
WA38500CC	Wedge Anchor Zinc ICC 3/8" X 5"	5"	3/8"	3/8"	2-1/3"	30 ft lbs	50	200
WA38700CC	Wedge Anchor Zinc ICC 3/8" X 7"	7"	3/8"	3/8"	2-1/3"	30 ft lbs	50	100
WA12234CC*	Wedge Anchor Zinc ICC 1/2" X 2-3/4"	2-3/4"	1/2"	1/2"	2-1/3"	30 ft lbs	50	200
WA12334CC	Wedge Anchor Zinc ICC 1/2" X 3-3/4"	3-3/4"	1/2"	1/2"	2-1/3"	45 ft lbs	50	200
WA12412CC	Wedge Anchor Zinc ICC 1/2" X 4-1/2"	4-1/2"	1/2"	1/2"	2-1/3"	45 ft lbs	50	100
WA12512CC	Wedge Anchor Zinc ICC 1/2" X 5-1/2"	5-1/2"	1/2"	1/2"	2-1/3"	45 ft lbs	25	100
WA12700CC	Wedge Anchor Zinc ICC 1/2" X 7"	7"	1/2"	1/2"	2-1/3"	45 ft lbs	25	100
WA12100CC	Wedge Anchor Zinc ICC 1/2" X 10"	10"	1/2"	1/2"	2-1/3"	45 ft lbs	25	50
WA58312CC*	Wedge Anchor Zinc ICC 5/8" X 3-1/2"	3-1/2"	5/8"	5/8"	3-1/4"	75 ft lbs	20	80
WA58412CC	Wedge Anchor Zinc ICC 5/8" X 4-1/2"	4-1/2"	5/8"	5/8"	3-1/4"	75 ft lbs	20	80
WA58500CC	Wedge Anchor Zinc ICC 5/8" X 5"	5"	5/8"	5/8"	3-1/4"	75 ft lbs	20	80
WA58600CC	Wedge Anchor Zinc ICC 5/8" X 6"	6"	5/8"	5/8"	3-1/4"	75 ft lbs	20	40
WA58700CC	Wedge Anchor Zinc ICC 5/8" X 7"	7"	5/8"	5/8"	3-1/4"	75 ft lbs	20	40
WA58812CC	Wedge Anchor Zinc ICC 5/8" X 8-1/2"	8-1/2"	5/8"	5/8"	3-1/4"	75 ft lbs	20	40
WA34414CC*	Wedge Anchor Zinc ICC 3/4" X 4-1/4"	4-1/4"	3/4"	3/4"	3-3/4"	150 ft lbs	10	40
WA34434CC*	Wedge Anchor Zinc ICC 3/4" X 4-3/4"	4-3/4"	3/4"	3/4"	3-3/4"	150 ft lbs	10	40
WA34512CC	Wedge Anchor Zinc ICC 3/4" X 5-1/2"	5-1/2"	3/4"	3/4"	3-3/4"	150 ft lbs	10	40
WA34614CC	Wedge Anchor Zinc ICC 3/4" X 6-1/4"	6-1/4"	3/4"	3/4"	3-3/4"	150 ft lbs	10	40
WA34700CC	Wedge Anchor Zinc ICC 3/4" x 7"	7"	3/4"	3/4"	3-3/4"	150 ft lbs	10	40
WA34812CC	Wedge Anchor Zinc ICC 3/4" X 8-1/2"	8-1/2"	3/4"	3/4"	3-3/4"	150 ft lbs	10	20
WA34100CC	Wedge Anchor Zinc ICC 3/4" X 10"	10"	3/4"	3/4"	3-3/4"	150 ft lbs	10	20

*This size is less than the required minimum standard anchor length for strength design

Identification Code



Carbon Steel Wedge Anchors

Aerosmith®'s Wedge Anchor is designed for consistent performance in solid concrete or grout filled concrete masonry. The anchor is threaded and comes complete with a nut and washer. The body is made of carbon steel with an expansion clip. Anchor is driven into a pre-drilled hole which is the same diameter as the anchor body. The anchor is set by tightening the nut to the required torque value for optimum performance. To help identify the length of an installed anchor an identification code can be seen visually at the top of the anchor to determine length after the anchor has been installed.

APPLICATIONS:

- Barriers
- Railings
- Warehouse racking
- Conveyor systems
- Machinery
- Signage
- Fence posts
- Shelving
- Windows
- Overhead doors
- Electrical pipes
- Light fixtures

FEATURES & BENEFITS:

- Consistent performance in all types of concrete
- Drill size same as anchor size
- Easy and simple installation
- One piece design
- Comes complete with nuts and washers

BASE MATERIAL:

- Solid concrete
- Grout-filled masonry
- Hard stone

ANCHOR COMPONENT MATERIALS:

Carbon Steel Zinc Plated
(body, nut, washer and expansion clip)

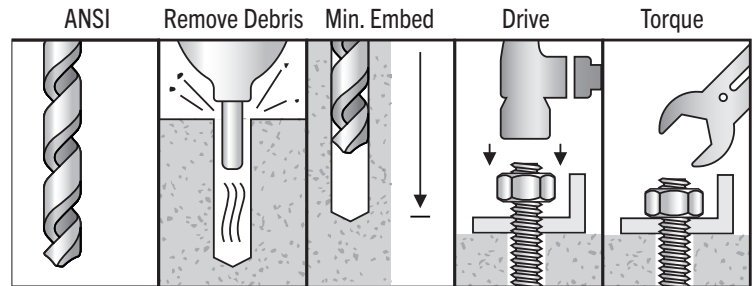

Part ID	Description	Overall Length	Diameter	ANSI Drill Diameter	Min. Embed	Max. Torque	Box Quantity	Carton Quantity
WAG14134	Wedge Anchor Zinc 1/4" X 1-3/4"	1-3/4"	1/4"	1/4"	1-1/8"	4 ft lbs	100	600
WAG14214	Wedge Anchor Zinc 1/4" X 2-1/4"	2-1/4"	1/4"	1/4"	1-1/8"	4 ft lbs	100	600
WAG14314	Wedge Anchor Zinc 1/4" X 3-1/4"	3-1/4"	1/4"	1/4"	1-1/8"	4 ft lbs	100	600
WAG38214	Wedge Anchor Zinc 3/8" X 2-1/4"	2-1/4"	3/8"	3/8"	1-5/8"	20 ft lbs	50	300
WAG38234	Wedge Anchor Zinc 3/8" X 2-3/4"	2-3/4"	3/8"	3/8"	1-5/8"	20 ft lbs	50	300
WAG38300	Wedge Anchor Zinc 3/8" X 3"	3"	3/8"	3/8"	1-5/8"	20 ft lbs	50	300
WAG38312	Wedge Anchor Zinc 3/8" X 3-1/2"	3-1/2"	3/8"	3/8"	1-5/8"	20 ft lbs	50	300
WAG38334	Wedge Anchor Zinc 3/8" X 3-3/4"	3-3/4"	3/8"	3/8"	1-5/8"	20 ft lbs	50	300
WAG38500	Wedge Anchor Zinc 3/8" X 5"	5"	3/8"	3/8"	1-5/8"	20 ft lbs	50	300
WAG38700	Wedge Anchor Zinc 3/8" X 7"	7"	3/8"	3/8"	1-5/8"	20 ft lbs	50	200
WAG12234	Wedge Anchor Zinc 1/2" X 2-3/4"	2-3/4"	1/2"	1/2"	2-1/4"	40 ft lbs	50	200
WAG12334	Wedge Anchor Zinc 1/2" X 3-3/4"	3-3/4"	1/2"	1/2"	2-1/4"	40 ft lbs	50	200
WAG12412	Wedge Anchor Zinc 1/2" X 4-1/2"	4-1/2"	1/2"	1/2"	2-1/4"	40 ft lbs	50	200
WAG12512	Wedge Anchor Zinc 1/2" X 5-1/2"	5-1/2"	1/2"	1/2"	2-1/4"	40 ft lbs	50	150
WAG12700	Wedge Anchor Zinc 1/2" X 7"	7"	1/2"	1/2"	2-1/4"	40 ft lbs	25	100
WAG12812	Wedge Anchor Zinc 1/2" X 8-1/2"	8-1/2"	1/2"	1/2"	2-1/4"	40 ft lbs	25	100
WAG58312	Wedge Anchor Zinc 5/8" X 3-1/2"	3-1/2"	5/8"	5/8"	2-3/4"	80 ft lbs	25	100
WAG58412	Wedge Anchor Zinc 5/8" X 4-1/2"	4-1/2"	5/8"	5/8"	2-3/4"	80 ft lbs	25	100
WAG58500	Wedge Anchor Zinc 5/8" X 5"	5"	5/8"	5/8"	2-3/4"	80 ft lbs	25	100
WAG58600	Wedge Anchor Zinc 5/8" X 6"	6"	5/8"	5/8"	2-3/4"	80 ft lbs	25	75
WAG58700	Wedge Anchor Zinc 5/8" X 7"	7"	5/8"	5/8"	2-3/4"	80 ft lbs	25	75
WAG58812	Wedge Anchor Zinc 5/8" X 8-1/2"	8-1/2"	5/8"	5/8"	2-3/4"	80 ft lbs	25	50
WAG34414	Wedge Anchor Zinc 3/4" X 4-1/4"	4-1/4"	3/4"	3/4"	3-3/8"	110 ft lbs	20	60
WAG34434	Wedge Anchor Zinc 3/4" X 4-3/4"	4-3/4"	3/4"	3/4"	3-3/8"	110 ft lbs	20	60
WAG34512	Wedge Anchor Zinc 3/4" X 5-1/2"	5-1/2"	3/4"	3/4"	3-3/8"	110 ft lbs	20	60
WAG34614	Wedge Anchor Zinc 3/4" X 6-1/4"	6-1/4"	3/4"	3/4"	3-3/8"	110 ft lbs	20	60
WAG34700	Wedge Anchor Zinc 3/4" X 7"	7"	3/4"	3/4"	3-3/8"	110 ft lbs	20	60
WAG34812	Wedge Anchor Zinc 3/4" X 8-1/2"	8-1/2"	3/4"	3/4"	3-3/8"	110 ft lbs	10	40
WAG34100	Wedge Anchor Zinc 3/4" X 10"	10"	3/4"	3/4"	3-3/8"	110 ft lbs	10	40
WAG16000	Wedge Anchor Zinc 1" X 6"	6"	1"	1"	4-1/2"	300 ft lbs	10	30
WAG16900	Wedge Anchor Zinc 1" X 9"	9"	1"	1"	4-1/2"	300 ft lbs	10	20
WAG11200	Wedge Anchor Zinc 1" X 12"	12"	1"	1"	4-1/2"	300 ft lbs	5	10

Identification Code



Wedge Anchor Type 304 Stainless Steel

Aerosmith®'s Wedge Anchor Type 304 Stainless Steel is designed for consistent performance in solid concrete or grout filled concrete masonry. The anchor is threaded and comes complete with a nut and washer which are made of 304 Stainless Steel. The body is made of 304 Stainless Steel with a 304 Stainless Steel expansion clip. Anchor is driven into a pre-drilled hole which is the same diameter as the anchor body. The anchor is set by tightening the nut to the required torque value for optimum performance. To help identify the length of an installed anchor an identification code can be seen visually at the top of the anchor to determine length after the anchor has been installed. The material type enables you to use this product in both internal and some external applications where corrosion resistance may be required. **To determine which product to use in external applications please consult an engineer.**

APPLICATIONS:

- Barriers
- Railings
- Warehouse racking
- Conveyor systems
- Machinery
- Signage
- Fence posts
- Shelving
- Windows
- Overhead doors
- Electrical pipes
- Light fixtures

FEATURES & BENEFITS:

- Consistent performance in all types of concrete
- Drill size same as anchor size
- Easy and simple installation
- One piece design
- Comes complete with nuts and washers

BASE MATERIAL:

- Solid concrete
- Grout-filled masonry
- Hard stone

ANCHOR COMPONENT MATERIALS:

304 Stainless Steel
(body, nut, washer and expansion clip)

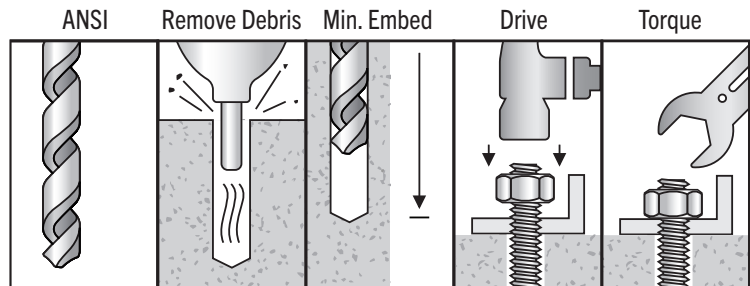

Part ID	Description	Overall Length	Diameter	ANSI Drill Diameter	Min. Embed	Max. Torque	Box Quantity	Carton Quantity
WA4SS14134	Wedge Anchor 304SS 1/4" X 1-3/4"	1-3/4"	1/4"	1/4"	1-1/8"	6 ft lbs	100	600
WA4SS14214	Wedge Anchor 304SS 1/4" X 2-1/4"	2-1/4"	1/4"	1/4"	1-1/8"	6 ft lbs	100	600
WA4SS14314	Wedge Anchor 304SS 1/4" X 3-1/4"	3-1/4"	1/4"	1/4"	1-1/8"	6 ft lbs	100	600
WA4SS38214	Wedge Anchor 304SS 3/8" X 2-1/4"	2-1/4"	3/8"	3/8"	1-3/8"	25 ft lbs	50	300
WA4SS38234	Wedge Anchor 304SS 3/8" X 2-3/4"	2-3/4"	3/8"	3/8"	1-3/8"	25 ft lbs	50	300
WA4SS38300	Wedge Anchor 304SS 3/8" X 3"	3"	3/8"	3/8"	1-3/8"	25 ft lbs	50	300
WA4SS38312	Wedge Anchor 304SS 3/8" X 3-1/2"	3-1/2"	3/8"	3/8"	1-3/8"	25 ft lbs	50	300
WA4SS38334	Wedge Anchor 304SS 3/8" X 3-3/4"	3-3/4"	3/8"	3/8"	1-3/8"	25 ft lbs	50	300
WA4SS38500	Wedge Anchor 304SS 3/8" X 5"	5"	3/8"	3/8"	1-3/8"	25 ft lbs	50	300
WA4SS12234	Wedge Anchor 304SS 1/2" X 2-3/4"	2-3/4"	1/2"	1/2"	1-7/8"	40 ft lbs	50	200
WA4SS12334	Wedge Anchor 304SS 1/2" X 3-3/4"	3-3/4"	1/2"	1/2"	1-7/8"	40 ft lbs	50	200
WA4SS12412	Wedge Anchor 304SS 1/2" X 4-1/2"	4-1/2"	1/2"	1/2"	1-7/8"	40 ft lbs	50	200
WA4SS12512	Wedge Anchor 304SS 1/2" X 5-1/2"	5-1/2"	1/2"	1/2"	1-7/8"	40 ft lbs	50	150
WA4SS12700	Wedge Anchor 304SS 1/2" X 7"	7"	1/2"	1/2"	1-7/8"	40 ft lbs	25	100
WA4SS58312	Wedge Anchor 304SS 5/8" X 3-1/2"	3-1/2"	5/8"	5/8"	2-1/2"	60 ft lbs	25	100
WA4SS58412	Wedge Anchor 304SS 5/8" X 4-1/2"	4-1/2"	5/8"	5/8"	2-1/2"	60 ft lbs	25	100
WA4SS58500	Wedge Anchor 304SS 5/8" X 5"	5"	5/8"	5/8"	2-1/2"	60 ft lbs	25	100
WA4SS58600	Wedge Anchor 304SS 5/8" X 6"	6"	5/8"	5/8"	2-1/2"	60 ft lbs	25	75
WA4SS58700	Wedge Anchor 304SS 5/8" X 7"	7"	5/8"	5/8"	2-1/2"	60 ft lbs	25	75
WA4SS58812	Wedge Anchor 304SS 5/8" X 8-1/2"	8-1/2"	5/8"	5/8"	2-1/2"	60 ft lbs	25	50
WA4SS34414	Wedge Anchor 304SS 3/4" X 4-1/4"	4-1/2"	3/4"	3/4"	3-3/8"	110 ft lbs	20	60
WA4SS34434	Wedge Anchor 304SS 3/4" X 4-3/4"	4-3/4"	3/4"	3/4"	3-3/8"	110 ft lbs	20	60
WA4SS34512	Wedge Anchor 304SS 3/4" X 5-1/2"	5-1/2"	3/4"	3/4"	3-3/8"	110 ft lbs	20	60
WA4SS34614	Wedge Anchor 304SS 3/4" X 6-1/4"	6-1/4"	3/4"	3/4"	3-3/8"	110 ft lbs	20	60
WA4SS34700	Wedge Anchor 304SS 3/4" X 7"	7"	3/4"	3/4"	3-3/8"	110 ft lbs	20	60
WA4SS34812	Wedge Anchor 304SS 3/4" X 8-1/2"	8-1/2"	3/4"	3/4"	3-3/8"	110 ft lbs	10	40
WA4SS34100	Wedge Anchor 304SS 3/4" X 10"	10"	3/4"	3/4"	3-3/8"	110 ft lbs	10	40
WA4SS16000	Wedge Anchor 304SS 1" X 6"	6"	1"	1"	4-1/2"	300 ft lbs	10	30
WA4SS19000	Wedge Anchor 304SS 1" X 9"	9"	1"	1"	4-1/2"	300 ft lbs	10	20
WA4SS11200	Wedge Anchor 304SS 1" X 12"	12"	1"	1"	4-1/2"	300 ft lbs	5	10

Identification Code



Wedge Anchor Type 316 Stainless Steel

Aerosmith®'s Wedge Anchor Type 316 Stainless Steel is designed for consistent performance in solid concrete or grout filled concrete masonry. The anchor is threaded and comes complete with a nut and washer which are made of 316 Stainless Steel. The body is made of 316 Stainless Steel with a 316 Stainless Steel expansion clip. Anchor is driven into a pre-drilled hole which is the same diameter as the anchor body. The anchor is set by tightening the nut to the required torque value for optimum performance. To help identify the length of an installed anchor an identification code can be seen visually at the top of the anchor to determine length after the anchor has been installed. The material grade enables you to use this product in both internal and some external applications where corrosion resistance may be required. **To determine which product to use in external applications please consult an engineer.**

APPLICATIONS:

- Barriers
- Railings
- Warehouse racking
- Conveyor systems
- Machinery
- Signage
- Fence posts
- Shelving
- Windows
- Overhead doors
- Electrical pipes
- Light fixtures

FEATURES & BENEFITS:

- Consistent performance in all types of concrete
- Drill size same as anchor size
- Easy and simple installation
- One piece design
- Comes complete with nuts and washers

BASE MATERIAL:

- Solid concrete
- Grout-filled masonry
- Hard stone

ANCHOR COMPONENT MATERIALS:

316 Stainless Steel
(body, nut, washer and expansion clip)

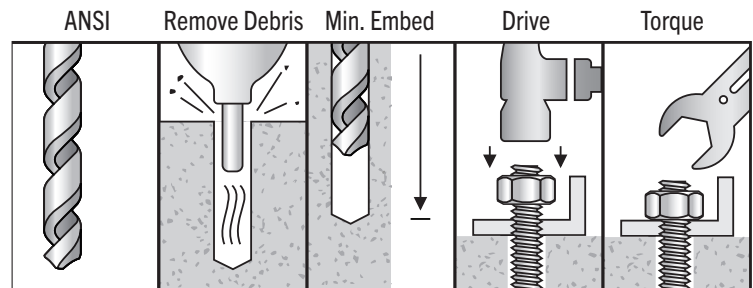

Part ID	Description	Overall Length	Diameter	ANSI Drill Diameter	Min. Embed	Max. Torque	Box Quantity	Carton Quantity
WA6SS14134	Wedge Anchor 316SS 1/4" X 1-3/4"	1-3/4"	1/4"	1/4"	1-1/8"	6 ft lbs	100	600
WA6SS14214	Wedge Anchor 316SS 1/4" X 2-1/4"	2-1/4"	1/4"	1/4"	1-1/8"	6 ft lbs	100	600
WA6SS14314	Wedge Anchor 316SS 1/4" X 3-1/4"	3-1/4"	1/4"	1/4"	1-1/8"	6 ft lbs	100	600
WA6SS38214	Wedge Anchor 316SS 3/8" X 2-1/4"	2-1/4"	3/8"	3/8"	1-3/8"	25 ft lbs	50	300
WA6SS38234	Wedge Anchor 316SS 3/8" X 2-3/4"	2-3/4"	3/8"	3/8"	1-3/8"	25 ft lbs	50	300
WA6SS38300	Wedge Anchor 316SS 3/8" X 3"	3"	3/8"	3/8"	1-3/8"	25 ft lbs	50	300
WA6SS38312	Wedge Anchor 316SS 3/8" X 3-1/2"	3-1/2"	3/8"	3/8"	1-3/8"	25 ft lbs	50	300
WA6SS38334	Wedge Anchor 316SS 3/8" X 3-3/4"	3-3/4"	3/8"	3/8"	1-3/8"	25 ft lbs	50	300
WA6SS38500	Wedge Anchor 316SS 3/8" X 5"	5"	3/8"	3/8"	1-3/8"	25 ft lbs	50	300
WA6SS12234	Wedge Anchor 316SS 1/2" X 2-3/4"	2-3/4"	1/2"	1/2"	1-7/8"	40 ft lbs	50	200
WA6SS12334	Wedge Anchor 316SS 1/2" X 3-3/4"	3-3/4"	1/2"	1/2"	1-7/8"	40 ft lbs	50	200
WA6SS12412	Wedge Anchor 316SS 1/2" X 4-1/2"	4-1/2"	1/2"	1/2"	1-7/8"	40 ft lbs	50	200
WA6SS12512	Wedge Anchor 316SS 1/2" X 5-1/2"	5-1/2"	1/2"	1/2"	1-7/8"	40 ft lbs	50	150
WA6SS12700	Wedge Anchor 316SS 1/2" X 7"	7"	1/2"	1/2"	1-7/8"	40 ft lbs	25	100
WA6SS58312	Wedge Anchor 316SS 5/8" X 3-1/2"	3-1/2"	5/8"	5/8"	2-1/2"	60 ft lbs	25	100
WA6SS58412	Wedge Anchor 316SS 5/8" X 4-1/2"	4-1/2"	5/8"	5/8"	2-1/2"	60 ft lbs	25	100
WA6SS58500	Wedge Anchor 316SS 5/8" X 5"	5"	5/8"	5/8"	2-1/2"	60 ft lbs	25	100
WA6SS58600	Wedge Anchor 316SS 5/8" X 6"	6"	5/8"	5/8"	2-1/2"	60 ft lbs	25	75
WA6SS58700	Wedge Anchor 316SS 5/8" X 7"	7"	5/8"	5/8"	2-1/2"	60 ft lbs	25	75
WA6SS58812	Wedge Anchor 316SS 5/8" X 8-1/2"	8-1/2"	5/8"	5/8"	2-1/2"	60 ft lbs	25	50
WA6SS34414	Wedge Anchor 316SS 3/4" X 4-1/4"	4-1/4"	3/4"	3/4"	3-3/8"	110 ft lbs	20	60
WA6SS34434	Wedge Anchor 316SS 3/4" X 4-3/4"	4-3/4"	3/4"	3/4"	3-3/8"	110 ft lbs	20	60
WA6SS34512	Wedge Anchor 316SS 3/4" X 5-1/2"	5-1/2"	3/4"	3/4"	3-3/8"	110 ft lbs	20	60
WA6SS34614	Wedge Anchor 316SS 3/4" X 6-1/4"	6-1/4"	3/4"	3/4"	3-3/8"	110 ft lbs	20	60
WA6SS34700	Wedge Anchor 316SS 3/4" X 7"	7"	3/4"	3/4"	3-3/8"	110 ft lbs	20	60
WA6SS34812	Wedge Anchor 316SS 3/4" X 8-1/2"	8-1/2"	3/4"	3/4"	3-3/8"	110 ft lbs	10	40



Sure-Bolt®

Suitable for installation in CRACKED CONCRETE, UNCRACKED CONCRETE, REINFORCED CONCRETE & STONE.

The Aerosmith® Sure Bolt® is a one-piece, heavy duty screw anchor with a finished hex head. The anchor is manufactured from carbon steel and is heat treated. The Sure-Bolt® is available in a variety of sizes from 1/4 to 3/4 inch. The hex head diameter is larger than the diameter of the anchor and is formed with serrations on the underside. The anchor can be installed in a pre-drilled hole with a powered impact wrench or a torque wrench. The anchor threads cut into concrete on the sides of the hole and interlock with the base material during the installation. Once installed they are easily identifiable by head markings with ASF on the head. Suitable base materials include normal weight concrete, and lightweight concrete. The anchor is designed for consistent and reliable performance in cracked and uncracked concrete.

APPLICATIONS:

- Structural anchoring in cracked and uncracked concrete, including industrial environments
- Glazing, windows and shop windows
- Industrial racking and conveyor systems
- Installation of railings and handrails in interiors applications
- Anchoring of machinery, boilers, signs, stadium seating, facade substructures, etc.
- Anchoring through wood into concrete base materials
- Removable

FEATURES & BENEFITS:

- Quick and easy installation
- Use in cracked and uncracked concrete
- Use for medium-heavy duty loads.
- Finished hex head
- Removable
- One piece assembly
- Variety of length and diameters
- Suitable when reduced distance to edge and between anchors is required
- Mechanical interlock between concrete and thread
- For static and quasi static loads
- Can be un-installed leaving the surface clear with no obstructions

APPROVALS:

Category 1 Cracked & Uncracked Concrete ICC-ES ESR-4414
 IBC Listed 2006, 2009, 2012, 2015, 2018, 2021
 IRC Listed 2006, 2009, 2012, 2015, 2018, 2021
 CBC 2019 Listed
 CRC 2019 Listed
 LABC 2020 Listed
 LARC 2020 Listed
 FBC 2020 Listed
 FRC 2020 Listed



BASE MATERIAL:

- Normal weight and lightweight concrete
- Reinforced concrete
- Cracked and uncracked concrete

ANCHOR COMPONENT MATERIALS:

Carbon Steel Body, Zinc Plated, with a hex washer head

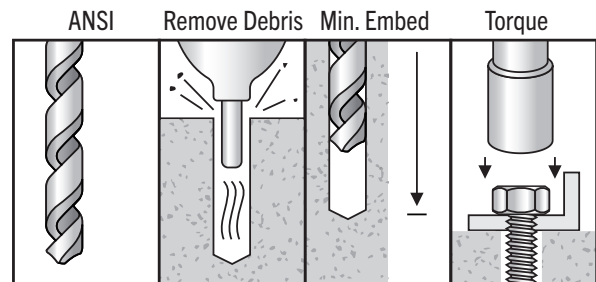

Part ID	Description	Overall Length	Diameter	ANSI Drill Diameter	Min. Embed	Max. Torque	Box Quantity	Carton Quantity
CB14114CC*	1/4" x 1-1/4"	1-1/4"	1/4"	1/4"	1"	24 ft lbs	100	800
CB14134CC*	1/4" x 1-3/4"	1-3/4"	1/4"	1/4"	1-1/2"	24 ft lbs	100	800
CB14214CC*	1/4" x 2-1/4"	2-1/4"	1/4"	1/4"	1-5/8"	24 ft lbs	100	600
CB14300CC*	1/4" x 3"	3"	1/4"	1/4"	1-5/8"	24 ft lbs	50	400
CB38134CC*	3/8" x 1-3/4"	1-3/4"	3/8"	3/8"	1-1/2"	35 ft lbs	50	200
CB38212CC	3/8" x 2-1/2"	2-1/2"	3/8"	3/8"	2-1/4"	35 ft lbs	50	200
CB38300CC	3/8" x 3"	3"	3/8"	3/8"	2-1/2"	35 ft lbs	50	200
CB38400CC	3/8" x 4"	4"	3/8"	3/8"	2-1/2"	35 ft lbs	50	200
CB38500CC	3/8" x 5"	5"	3/8"	3/8"	2-1/2"	35 ft lbs	50	200
CB38600CC	3/8" x 6"	6"	3/8"	3/8"	2-1/2"	35 ft lbs	50	200
CB12200CC*	1/2" x 2"	2"	1/2"	1/2"	1-3/4"	35 ft lbs	50	100
CB12212CC*	1/2" x 2-1/2"	2-1/2"	1/2"	1/2"	2-1/4"	45 ft lbs	50	100
CB12300CC	1/2" x 3"	3"	1/2"	1/2"	2-3/4"	45 ft lbs	50	100
CB12400CC	1/2" x 4"	4"	1/2"	1/2"	3"	45 ft lbs	50	100
CB12500CC	1/2" x 5"	5"	1/2"	1/2"	3"	45 ft lbs	25	50
CB12600CC	1/2" x 6"	6"	1/2"	1/2"	3"	45 ft lbs	25	50
CB12800CC	1/2" x 8"	8"	1/2"	1/2"	3"	45 ft lbs	20	80
CB58300CC*	5/8" x 3"	3"	5/8"	5/8"	2-3/4"	85 ft lbs	25	50
CB58400CC	5/8" x 4"	4"	5/8"	5/8"	3-1/4"	85 ft lbs	25	50
CB58500CC	5/8" x 5"	5"	5/8"	5/8"	3-1/4"	85 ft lbs	25	50
CB58600CC	5/8" x 6"	6"	5/8"	5/8"	3-1/4"	85 ft lbs	20	40
CB58800CC	5/8" x 8"	8"	5/8"	5/8"	3-1/4"	85 ft lbs	20	40
CB34400CC	3/4" x 4"	4"	3/4"	3/4"	3-3/4"	115 ft lbs	20	40
CB34500CC	3/4" x 5"	5"	3/4"	3/4"	4"	115 ft lbs	20	40
CB34600CC	3/4" x 6"	6"	3/4"	3/4"	4"	115 ft lbs	10	20
CB34800CC	3/4" x 8"	8"	3/4"	3/4"	4"	115 ft lbs	10	20
CB34100CC	3/4" x 10"	10"	3/4"	3/4"	4"	115 ft lbs	10	20

*This size is less than the required minimum standard anchor length for strength design



Sure-Bolt® Extreme (Atlantis Coating)

Suitable for installation in CRACKED CONCRETE, UNCRACKED CONCRETE, REINFORCED CONCRETE & STONE.

The Sure-Bolt® Extreme is a one-piece heavy-duty Hex Head screw anchor, comprised of a Carbon steel body that is heat treated and then coated for corrosion resistance. It is available in 3/8, 1/2 and 5/8 diameters up to 6" in length. Just drill the same diameter hole as the anchor body and run the part in with either a corded/cordless impact wrench or a regular hand socket. The anchor threads cut into the concrete on the sides of the hole and interlock with the base material during installation. Suitable base materials include normal weight concrete, lightweight concrete, brick, and grout filled block. The anchor has also been evaluated by ICC-ES for consistent use and reliability in Cracked and Uncracked concrete, category 1.

The Sure-Bolt® Extreme is an excellent choice for both internal and external applications due to its multiple coating protection. First a layer of zinc is applied to the part, plus two layers of epoxy organic coating to follow. The coating will exceed 700 hours of salt spray before any red rust appears and is suitable for external environments with a service life that exceeds 25 years, making it an excellent choice for external applications. The coating is also resistant to Acids and Alkalis.

APPLICATIONS:

- Structural anchoring in cracked and uncracked concrete, including industrial environments
- Glazing, windows and shop windows
- Industrial racking and conveyor systems
- Installation of railings and handrails in interiors applications
- Anchoring of machinery, boilers, signs, stadium seating, facade substructures, etc.
- Anchoring through wood into concrete base materials
- Removable

BASE MATERIAL:

- Normal weight and lightweight concrete
- Reinforced concrete
- Cracked and uncracked concrete

FEATURES & BENEFITS:

- Quick and easy installation
- Use in cracked and uncracked concrete
- Use for medium-heavy duty loads.
- Finished hex head
- Removable
- One piece assembly
- Variety of length and diameters
- Suitable when reduced distance to edge and between anchors is required
- Mechanical interlock between concrete and thread
- For static and quasi static loads
- Can be un-installed leaving the surface clear with no obstructions

APPROVALS:

Category 1 Cracked & Uncracked Concrete I
 CC-ES ESR-4414
 IBC Listed 2009, 2012, 2015, 2018
 IRC Listed 2009, 2012, 2015,
 2018 CBC 2016 Listed CRC 2016 Listed LABC
 2017 Listed LARC 2017 Listed
 FBC 2017 Listed
 FRC 2017 Listed

**FOR INSTALLATION
 INSTRUCTIONS SEE PAGE 43.**

ANCHOR COMPONENT MATERIALS:

Carbon Steel Body, Zinc Plated, with a hex washer head with additional coating



Part ID	Product Name	Description	Overall Length	Diameter	ANSI Drill Diameter	Min. Embed	Max. Torque	Box Quantity	Carton Quantity
CB38300CCA	Atlantis Coating	3/8" x 3"	3"	3/8"	3/8"	2-1/2"	35 ft. lbs	50	200
CB38400CCA	Atlantis Coating	3/8" x 4"	4"	3/8"	3/8"	2-1/2"	35 ft. lbs	50	200
CB38500CCA	Atlantis Coating	3/8" x 5"	5"	3/8"	3/8"	2-1/2"	35 ft. lbs	50	200
CB12400CCA	Atlantis Coating	1/2" x 4"	4"	1/2"	1/2"	3"	45 ft. lbs	50	100
CB12500CCA	Atlantis Coating	1/2" x 5"	5"	1/2"	1/2"	3"	35 ft lbs	50	50
CB12600CCA	Atlantis Coating	1/2" x 6"	6"	1/2"	1/2"	3"	45 ft. lbs	50	50
CB58600CCA	Atlantis Coating	5/8" x 6"	6"	5/8"	5/8"	3-1/4"	85 ft. lbs	50	50



Concrete-Bolt Anchors

Suitable for installation in, UNCRACKED CONCRETE, REINFORCED CONCRETE & STONE.

The Aerosmith® Concrete-Bolt is a one-piece, heavy duty screw anchor with a finished hex head. The anchor is manufactured from carbon steel and is heat treated. The Concrete-Bolt is available in a variety of sizes from 3/8" to 5/8" inches. The hex head diameter is larger than the diameter of the anchor and is formed with serrations on the underside. The anchor can be installed in a pre-drilled hole with a powered impact wrench or a torque wrench. The anchor threads cut into concrete on the sides of the hole and interlock with the base material during the installation. Suitable base materials include normal weight concrete, and lightweight concrete. The anchor is designed for consistent and reliable performance in uncracked concrete.

APPLICATIONS:

- Structural anchoring in uncracked concrete, including industrial environments
- Glazing, windows and shop windows
- Industrial racking and conveyor systems
- Installation of railings and handrails in interiors applications
- Anchoring of machinery, boilers, signs, stadium seating, facade substructures, etc.
- Anchoring through wood into concrete base materials
- Removable

FEATURES & BENEFITS:

- Quick and easy installation
- Use in uncracked concrete
- Use for medium-heavy duty loads.
- Finished hex head
- Removable
- One piece assembly
- Variety of length and diameters
- Suitable when reduced distance to edge and between anchors is required
- Mechanical interlock between concrete and thread
- For static and quasi static loads
- Can be un-installed leaving the surface clear with no obstructions

Part ID	Description	Overall Length	Diameter	ANSI Drill Diameter	Min. Embed	Max. Torque	Box Quantity	Carton Quantity
CB38600SR	3/8" x 3"	3"	3/8"	3/8"	2-1/2"	35 ft lbs.	50	300
CB38300SR	3/8" x 6"	6"	3/8"	3/8"	2-1/2"	35 ft lbs.	15	45
CB12300SR	1/2" x 3"	3"	1/2"	1/2"	2-3/4"	45 ft lbs.	50	200
CB12400SR	1/2" x 4"	4"	1/2"	1/2"	3"	45 ft lbs.	50	150
CB12500SR	1/2" x 5"	5"	1/2"	1/2"	3"	45 ft lbs.	25	150
CB12600SR	1/2" x 6"	6"	1/2"	1/2"	2-1/2"	45 ft lbs.	25	75
CB58400SR	5/8" x 4"	4"	5/8"	5/8"	3-1/4"	85 ft lbs.	25	125
CB58600SR	5/8" x 6"	6"	5/8"	5/8"	3-1/4"	85 ft lbs.	25	75



Sleeve Anchor Carbon Steel

Aerosmith®'s Sleeve Anchor is an all-steel pre-assembled anchor that can be used in a variety of solid base materials. Most popular base materials include concrete and masonry. They are available in multiple head styles, such as, hex nut, acorn nut and flat head to give you the finished appearance for your specific application. Simply drill the same diameter hole as the anchor and install anchor through fixture and then tighten to required torque. Sleeve Anchor is an all-steel pre-assembled anchor that can be used in a variety of solid base materials. Most popular base materials include concrete and masonry.

APPLICATIONS:

- Light to medium duty signage
- Electrical boxes
- Shelving
- Junction boxes
- Door frames
- Window frames

FEATURES & BENEFITS:

- Variety of head styles
- Can be used in a variety of base materials
- All steel component design
- Pre-assembled anchor for quick installation
- Anchor size is the same as hole size.

BASE MATERIAL:

- Concrete
- Grout filled masonry
- Block (expansion must be in solid portion)
- Brick
- Stone

ANCHOR COMPONENT MATERIALS:

Carbon Steel Zinc Plated
(body, nut & washer, expansion sleeve Carbon Steel)

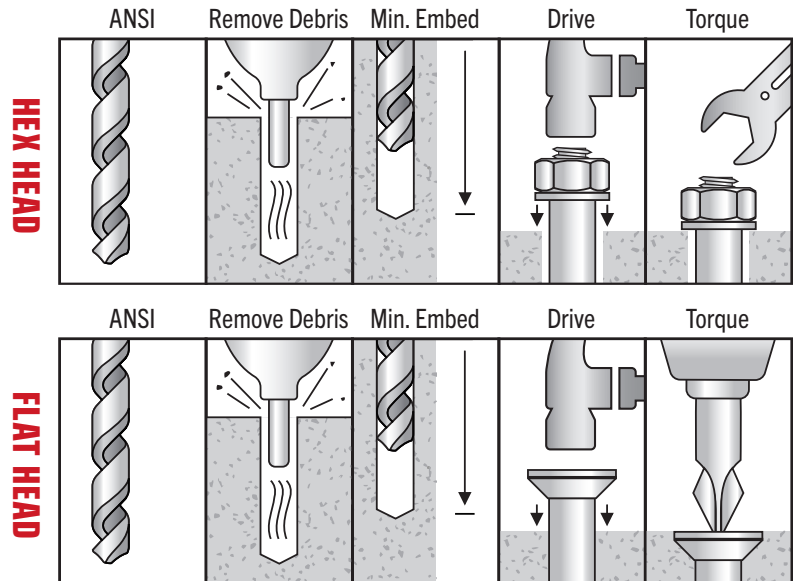

Part ID	Description	Usable Length	Diameter	ANSI Drill Diameter	Max. Fixture Thickness	Max. Torque	Box Quantity	Carton Quantity
SAH516112	5/16" X 1-1/2"	1-1/2"	5/16"	5/16"	1"	12 ft lbs	100	600
SAH516212	5/16" X 2-1/2"	2-1/2"	5/16"	5/16"	1"	12 ft lbs	100	500
SAH381780	3/8" X 1-7/8"	1-7/8"	3/8"	3/8"	1-1/4"	12 ft lbs	50	400
SAH383000	3/8" X 3"	3"	3/8"	3/8"	1-1/4"	18 ft lbs	50	250
SAH384000	3/8" X 4"	4"	3/8"	3/8"	1-1/4"	18 ft lbs	50	250
SAH122120	1/2" X 2-1/2"	2-1/2"	1/2"	1/2"	1-1/2"	18 ft lbs	25	150
SAH582140	5/8" X 2-1/4"	2-1/4"	5/8"	5/8"	2"	50 ft lbs	25	125
SAH123000	1/2" X 3"	3"	1/2"	1/2"	1-1/2"	26 ft lbs	25	150
SAH126000	1/2" X 6"	6"	1/2"	1/2"	1-1/2"	26 ft lbs	10	50
SAH583000	5/8" X 3"	3"	5/8"	5/8"	2"	26 ft lbs	25	125
SAH584140	5/8" X 4-1/4"	4-1/4"	5/8"	5/8"	2"	50 ft lbs	10	80
SAH585340	5/8" X 5-3/4"	5-3/4"	5/8"	5/8"	2"	50 ft lbs	10	50
SAH342140	3/4" X 2-1/2"	2-1/2"	3/4"	3/4"	2-1/4"	90 ft lbs	10	80
SAH344140	3/4" X 4-1/4"	4-1/4"	3/4"	3/4"	2-1/4"	50 ft lbs	10	40
SAH346140	3/4" X 6-1/4"	6-1/4"	3/4"	3/4"	2-1/4"	90 ft lbs	10	30
SAH348140	3/4" X 8-1/4"	8-1/4"	3/4"	3/4"	2-1/4"	90 ft lbs	5	20
Part ID	Description	Usable Length	Diameter	ANSI Drill Diameter	Max. Fixture Thickness	Max. Torque	Box Quantity	Carton Quantity
SAA145800	1/4" X 5/8"	5/8"	1/4"	1/4"	1/2"	90 ft lbs	100	1000
SAA141380	1/4" X 1-3/8"	1-3/8"	1/4"	1/4"	1/2"	6 ft lbs	100	800
SAA142140	1/4" X 2-1/4"	2-1/4"	1/4"	1/4"	1/2"	6 ft lbs	100	600
SAC382340	3/8" X 2-3/4"	2-3/4"	3/8"	3/8"	1-1/4"	6 ft lbs	50	300
SAC384000	3/8" X 4"	4"	3/8"	3/8"	1-1/4"	18 ft lbs	50	250
SAC385000	3/8" X 5"	5"	3/8"	3/8"	1-1/4"	18 ft lbs	50	250
SAC386000	3/8" X 6"	6"	3/8"	3/8"	1-1/4"	18 ft lbs	50	250

304 Stainless Steel Sleeve Anchor

FOR INSTALLATION INSTRUCTIONS SEE PAGE 45.

The Aerosmith® 304 Stainless steel sleeve anchor is a preassembled expansion anchor that can be used in a variety of base materials which include normal weight concrete, brick, and grout filled block. This anchor is available in both 3/8 and 1/2 diameters and comes with either an acorn nut or finished hex nut. Great for both internal and external applications where corrosion may be of concern. Simply drill the same size hole as the anchor diameter using a carbide drill bit and tap the anchor through your fixture and tighten to the required torque value. As you tighten the nut, the bolt pulls through the sleeve creating expansion.



Sleeve Anchors 304 Stainless Steel Hex Head

Sleeve Anchors 304 Stainless Steel Acorn Head

FEATURES & BENEFITS:

- Variety of head styles
- Can be used in a variety of base materials
- Pre-assembled anchor for quick installation
- Anchor size is the same as hole size.

BASE MATERIAL:

- Normal weight and lightweight concrete
- Reinforced concrete

ANCHOR COMPONENT MATERIALS:

- 304 Stainless Steel body
- with 304 Stainless Steel Washer & Nut/additional coating

Part ID	Description	Overall Length	Overall Diameter	ANSI Drill Diameter	ANSI Drill Diameter	Max Fixture Thickness	Box Quantity	Carton Quantity
SAH4SS381780	3/8" x 1 7/8" (Hex Head)	1-7/8"	3/8"	3/8"	2-1/2"	1-1/4"	50	400
SAH4SS383000	3/8" x 3" (Hex Head)	3"	3/8"	3/8"	2-1/2"	1-1/4"	50	250
SAH4SS122120	1/2" x 2-1/2" (Hex Head)	2-1/2"	1/2"	1/2"	2-1/2"	1-1/2"	25	150
SAH4SS123000	1/2" x 3" (Hex Head)	3"	1/2"	1/2"	3"	1-1/2"	25	150
SAH4SS123340	1/2" X 3-3/4" (Hex Head)	3-3/4"	1/2"	1/2"	3"	1-1/2"	25	150
SAA4SS141380	1/4" x 1-3/8" (Acorn Head)	1-3/8"	1/4"	1/4"	3-1/4"	1/2"	100	800

Caulking Anchors

Aerosmith®'s Caulking Anchor is an internally threaded part whose sleeve is made of Zamac alloy. This anchor comes pre-assembled and can be used in concrete, brick, block and stone. Pre-drill the proper hole diameter and length, tap anchor into pre-drilled hole and properly set using the proper Aerosmith® caulking setting tool. Once properly set, put fixture in place and use the required machine bolt for proper attachment. This anchor can also be used in normal weight concrete, grout filled concrete, masonry (CMU) brick and stone. This anchor is not recommended for overhead applications.



APPLICATIONS:

- Window frame installations
- Screens enclosures
- Sliding doors
- Storm shutters
- Light to medium duty signage
- Seating

FEATURES & BENEFITS:

- Easy to install
- Can be used in a variety of base materials
- Internally threaded anchor for easy removability
- Can be used in shallow embedments
- Corrosion resistant anchor body

BASE MATERIAL:

- Concrete
- Block
- Brick
- Stone

ANCHOR COMPONENT MATERIALS:

Lead Alloy Body and internally threaded Zamac Alloy Cone

CAULKING SETTING TOOLS:

- CIT10 10-24
- CIT14 1/4"
- CIT516 5/16"
- CIT38 3/8"
- CIT12 1/2"

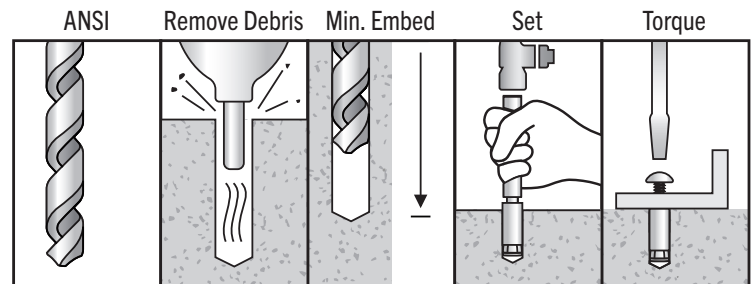

Part ID	Description	ANSI Drill Diameter	Min. Embed	Max. Torque	Box Quantity	Carton Quantity	Use with Caulking Tool
CI1024	Caulking 10 - 24	3/8"	5/8"	20 lbs Max	100	1000	CIT10
CI1420	Caulking 1/4" - 20	1/2"	7/8"	60 lbs Max	100	600	CIT14
CI51618	Caulking 5/16" - 18	5/8"	1"	7 ft. lbs Max	50	300	CIT516
CI3816	Caulking 3/8" - 16	3/4"	1-1/4"	10 ft.-lbs Max	50	300	CIT38
CI1213	Caulking 1/2" - 13	7/8"	1-1/2"	15 ft.-lbs Max	50	250	CIT12
Use with Caulking Anchor							
CIT10	Caulking Setting Tool 10 - 24	N/A	-	-	1	300	10 - 24 CI1024
CIT14	Caulking Setting Tool 1/4"	N/A	-	-	1	200	1/4" CI1420
CIT516	Caulking Setting Tool 5/16"	N/A	-	-	1	150	5/16" CI51618
CIT38	Caulking Setting Tool 3/8"	N/A	-	-	1	100	3/8" CI3816
CIT12	Caulking Setting Tool 1/2"	N/A	-	-	1	60	1/2" CI1213



Drop-ins

Aerosmith®'s Drop-in is a machine type bolt anchor available in 304 and 316 SS as well as carbon steel. The body is internally threaded for use in flush mount applications and solid base materials. Aerosmith® also offers a coil thread version for concrete forming applications available in both 1/2" and 3/4" diameters. A shallow embedment drop-in is also available which is made from carbon steel and can be used in solid concrete, hollow concrete, plank, hardstone and solid brick. Typical applications include hanging threaded rod overhead. Installation is easy. Pre-drill a hole using the proper diameter for the anchor, tap anchor into pre-drilled hole until flush with the base material. Use the appropriate setting tool to properly set the anchor and hammer the back of the setting tool until neck is flush with the top of the anchor. Put fixture in place and insert the machine bolt and tighten to the required torque. If using overhead, insert threaded rod to the minimal thread engagement which should be equal to the nominal diameter of the threaded insert. This product can be used in overhead applications.

APPLICATIONS:

- Cable trays
- Fire sprinklers
- Suspended conduit
- Concrete form-work
- Suspended ceiling and lighting
- Telecommunication installations

FEATURES & BENEFITS:

- Easy to remove
- Allows for short embedment
- Lipped version installs flush
- Non-lipped version for deeper embedment
- High load values
- Available in different material types

BASE MATERIAL:

- Solid concrete
- Hard stone
- Solid block

APPROVALS:

UL Listed for 3/8" & 1/2" diameters
Mini Drop-In not included.

ANCHOR COMPONENT MATERIALS:

- Carbon Steel – Zinc Plated
- Stainless Steel Type 304
- Stainless Steel Type 316

SETTING TOOL



SHALLOW EMBED SETTING

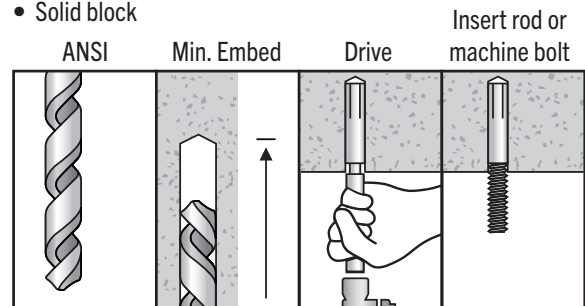

Part ID	Product Name	Description	Overall Length	Thread Diameter	ANSI Drill Diameter	Min. Embed	Rod Size: Torque	Box Quantity	Carton Quantity
DI14	Carbon Steel Drop In	1/4"	1"	1/4"	3/8"	1"	Rod Size: 1/4" Torque 5 ft lbs	100	1000
DI38	Carbon Steel Drop In	3/8"	1-9/16"	3/8"	1/2"	1-9/16"	Rod Size: 3/8" Torque 10 ft lbs	50	500
DI12	Carbon Steel Drop In	1/2"	2"	1/2"	5/8"	2"	Rod Size: 1/2" Torque 20 ft lbs	50	300
DI58	Carbon Steel Drop In	5/8"	2-1/2"	5/8"	7/8"	2-1/2"	Rod Size: 5/8" Torque 40 ft lbs	25	125
DI34	Carbon Steel Drop In	3/4"	3-3/16"	3/4"	1"	3-3/16"	Rod Size: 3/4" Torque 80 ft lbs	10	50
DIC12	Coil Thread Drop in	1/2"	2"	1/2"	5/8"	2"	Rod Size: 1/2" Torque 20 ft lbs	50	300
DIC34	Coil Thread Drop in	3/4"	3-3/16"	3/4"	1"	3-3/16"	Rod Size: 3/4" Torque 80 ft lbs	10	90
DIL14	Carbon Steel Shallow Embedment Drop In	w/Lip 1/4"	5/8"	1/4"	3/8"	5/8"	Rod Size: 1/4" Torque 5 ft lbs	100	1000
DIL38	Carbon Steel Shallow Embedment Drop In	w/Lip 3/8"	3/4"	3/8"	1/2"	3/4"	Rod Size: 3/8" Torque 10 ft lbs	100	1000
DIL12	Carbon Steel Shallow Embedment Drop In	w/Lip 1/2"	1"	1/2"	5/8"	1"	Rod Size: 1/2" Torque 20 ft lbs	25	300
DI4SS14	Stainless Steel Drop In	304 SS 1/4"	1"	1/4"	3/8"	1"	Rod Size: 1/4" Torque 5 ft lbs	100	1000
DI4SS38	Stainless Steel Drop In	304 SS 3/8"	1-9/16"	3/8"	1/2"	1-9/16"	Rod Size: 3/8" Torque 10 ft lbs	50	500
DI4SS12	Stainless Steel Drop In	304 SS 1/2"	2"	1/2"	5/8"	2"	Rod Size: 1/2" Torque 20 ft lbs	50	300
DI6SS14	Stainless Steel Drop In	316 SS 1/4"	1"	1/4"	3/8"	1"	Rod Size: 1/4" Torque 5 ft lbs	100	1000
DI6SS38	Stainless Steel Drop In	316 SS 3/8"	1-9/16"	3/8"	1/2"	1-9/16"	Rod Size: 3/8" Torque 10 ft lbs	50	500
DI6SS12	Stainless Steel Drop In	316 SS 1/2"	2"	1/2"	5/8"	2"	Rod Size: 1/2" Torque 20 ft lbs	50	300
DST14	Drop-In Setting Tool	1/4"						1	250
DST38	Drop-In Setting Tool	3/8"						1	100
DST12	Drop-In Setting Tool	1/2"						1	100
DST58	Drop-In Setting Tool	5/8"						1	50
DST34	Drop-In Setting Tool	3/4"						1	25
DSTM14	Shallow Embedment Drop In Setting Tool	1/4"						1	50
DSTM38	Shallow Embedment Drop In Setting Tool	3/8"						1	50
DSTM12	Shallow Embedment Drop In Setting Tool	1/2"						1	50



Hollow Block Anchors

Aerosmith®'s Hollow Block anchor is designed for anchoring in hollow base materials such as hollow concrete block, hollow core pre-cast concrete plank, and brick with weep hole. The Hollow Block anchor is a good option to use when the wall thickness available is 1" or less. The anchor design take this issue in account.

APPLICATIONS:

- Anchoring to concrete block
- Suspending conduit
- Cable trays and strut
- Pipe supports
- Fastening to precast hollow core plank
- Fire sprinkler
- Suspended lighting
- Removable anchorage

FEATURES & BENEFITS:

- Tapered sleeve
- Serrated cone
- Large bearing area which reduces the amount of compression force applied to the base material during the expansion process

BASE MATERIAL:

- Concrete
- Block
- Brick
- Pre-cast Hollow Core Plank
- Stone



ANCHOR COMPONENT MATERIALS:

Zamac Alloy with Carbon Steel Cone

Part ID	Description	Overall Length	Box	Carton Quantity
HBA12	1/2"	1-3/4"	50	250
HBA38	3/8"		50	300
HBAT12	1/2"	Setting Tool		1
HBAT38	3/8"	Setting Tool		1

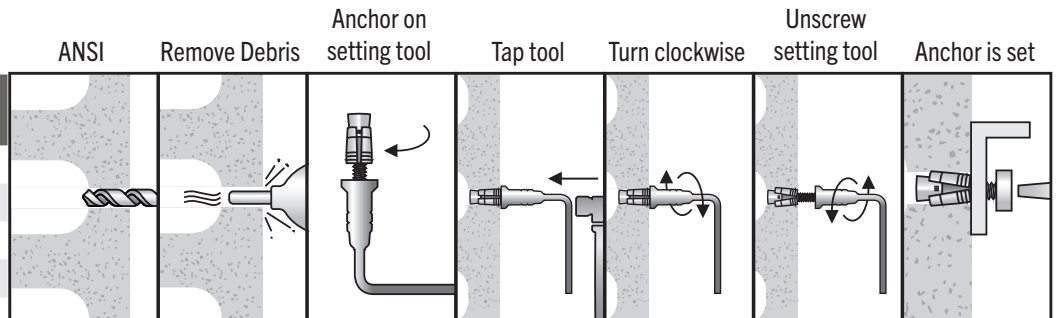

Dual Machine Bolt Anchors

Aerosmith®'s Dual Machine Bolt Anchors can be used in solid concrete, brick, block and stone. The Dual Machine Bolt Anchor is made of die cast Zamac alloy and is corrosive resistant. Although the product can be used in many base materials it is sometimes used in questionable materials because it expands against the concrete at two points. Sizes are available from 1/4" to 3/4" diameters. Drill the proper diameter hole to the specified embedment, tap anchor into pre-drill hole until flush. Put fixture in place and insert machine bolt. Tighten to required torque to properly set the anchor. This product is not recommended for overhead applications.

APPLICATIONS:

- Cable trays
- Scaffolding
- Handrails
- Signage
- Strut
- Machinery
- Light fixtures
- Sprinkler pipe

FEATURES & BENEFITS:

- Internal thread accepts machine bolts
- Corrosion resistance
- Easy to remove installations

BASE MATERIAL:

- Concrete
- Grout filled block
- Brick
- Stone

ANCHOR COMPONENT MATERIALS:

Zinc Alloy

Part ID	Description	Overall Length	ANSI Drill Diameter	Min. Embed	Max. Torque	Box	Carton Quantity
DB14	1/4"	1-3/8"	1/2"	1-1/4"	5 ft lbs	50	500
DB516	5/16"	1-5/8"	5/8"	1-1/2"	7 ft lbs	50	500
DB38	3/8"	2"	3/4"	1-3/4"	10 ft lbs	50	250
DB12	1/2"	2-1/2"	7/8"	2-1/4"	20 ft lbs	25	250
DB58	5/8"	2-3/4"	1"	2-1/2"	20 ft lbs	25	125
DB34	3/4"	3-15/16"	1-1/4"	3-1/2"	60 ft lbs	10	50

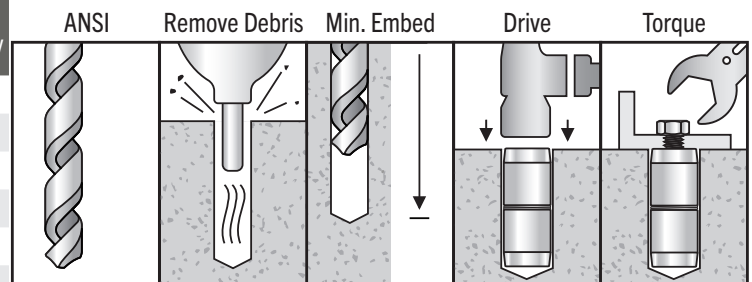



Machine Bolt Anchors

The Machine Bolt Anchor can be used in concrete, block, brick and stone. The anchor consists of a set of expansion shields and an expander cone. The product is manufactured from zinc alloy. As the anchor is tightened, the cone gets drawn into the expansion shield which compresses them against the base material. This product is not recommended in overhead applications.

APPLICATIONS:

- Cable trays
- Scaffolding
- Handrails
- Signage
- Strut
- Machinery
- Light fixtures
- Sprinkler pipe

FEATURES & BENEFITS:

- Internal thread accepts machine bolts
- Corrosion resistance
- Easy to remove installations

BASE MATERIAL: ANCHOR COMPONENT MATERIALS:

- Concrete
- Grout filled block
- Brick
- Stone
- Zinc Alloy

Part ID	Description	Overall Length	ANSI Drill Diameter	Min. Embed	Max. Torque	Box	Carton Quantity
SNG14	1/4"	1-5/16"	1/2"	1-3/8"	5 ft. lbs	50	250
SNG516	5/16"	1-1/2"	5/8"	1-5/8"	7 ft. lbs	50	250
SNG38	3/8"	1-1/2"	5/8"	1-5/8"	10 ft. lbs	50	250
SNG12	1/2"	2-1/16"	7/8"	2-1/2"	20 ft. lbs	25	125
SNG58	5/8"	2-5/8"	1"	2-3/4"	30 ft. lbs	25	125

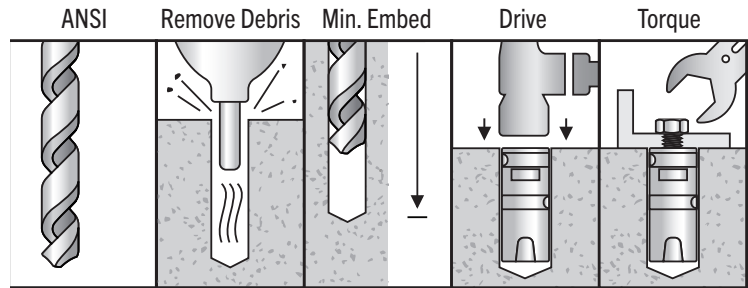

Sure-Lag

The Aerosmith® Sure-Lag can be used to anchor into a variety of base materials such as concrete, brick and grout filled block. Although best suited for light to medium duty fastening. Sure-Lag Anchors are available in 1/4", 5/16", 3/8", 1/2", 5/8" diameters, and are available in both short and long versions. The short version is typically used on harder base materials while the longer Sure-Lags are typically used on softer base materials where more embedment is required. Sure-Lags are made from zinc which enables them to be used in many different environmental conditions. To set, drill the proper size hole, tap Sure-Lag into the base material, put fixture in place and thread machine bolt into the Sure-Lag until tight. The fixture is removable because the Sure-Lag anchor remains in the hole and only the lag screw can be unscrewed and removed. Not recommended for overhead applications.

APPLICATIONS:

- Light to medium duty signage
- Electrical boxes
- Hand rails
- Anchoring strut to masonry walls

FEATURES & BENEFITS:

- Removable
- Can be used in a variety of base materials
- Non-corrosive

BASE MATERIAL: ANCHOR COMPONENT MATERIALS:

- Concrete
- Grout filled block
- Brick
- Zinc Alloy

Part ID	Description	ANSI Drill Diameter	Min. Embed	Max. Torque	Box Quantity	Carton Quantity
LS14S	1/4" Short	1/2"	1"	5 ft lbs	50	500
LS14L	1/4" Long	1/2"	1-1/2"	5 ft lbs	50	500
LS516S	5/16" Short	1/2"	1-1/4"	7 ft lbs	50	500
LS516L	5/16" Long	1/2"	1-3/4"	7 ft lbs	50	500
LS38S	3/8" Short	5/8"	1-3/4"	10 ft lbs	50	500
LS38L	3/8" Long	5/8"	2-1/2"	10 ft lbs	50	250
LS12S	1/2" Short	3/4"	2"	20 ft lbs	50	500
LS12L	1/2" Long	3/4"	3"	20 ft lbs	50	200
LS58S	5/8" Short	7/8"	2"	30 ft lbs	25	125

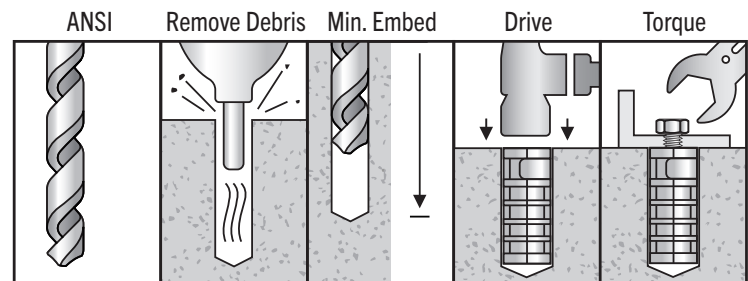

SDS-Plus 4 Cutter Carbide Drill Bits for Concrete, Brick, Block and Stone

The SDS carbide tipped drill bit is a masonry bit designed for concrete drilling. But unlike ordinary bits, the SDS drill bit provides a longer service life. These carbide tipped masonry drill bits are more durable due to the hardness of the heads-making them tougher and more resistant to extreme loads.

FEATURES & BENEFITS:

- 4 Cutter Head.
- Reduces operator fatigue.
- Provides a longer service life of the tool. Clip designed for easy display.
- To be used in Concrete, Brick, Block and Stone.
- Flute design for fast dust extraction.



4 Cutter Head.

Reduces operator fatigue.

Provides a longer service life of the tool.

Part ID	Description	Box Quantity	Carton Quantity
SDS532600	SDS CARBIDE DRILL 5/32 X 4 X 6	1	1
SDS316400	SDS CARBIDE DRILL 3/16 X 2 X 4	1	1
SDS316600	SDS CARBIDE DRILL 3/16 X 4 X 6	1	1
SDS316800	SDS CARBIDE DRILL 3/16 X 6 X 8	1	1
SDS732800	SDS CARBIDE DRILL 7/32 X 6 X 8	1	1
SDS144000	SDS CARBIDE DRILL 1/4 X 2 X 4	1	1
SDS146000	SDS CARBIDE DRILL 1/4 X 4 X 6	1	1
SDS148000	SDS CARBIDE DRILL 1/4 X 6 X 8	1	1
SDS141200	SDS CARBIDE DRILL 1/4 X 10 X 12	1	1
SDS141400	SDS CARBIDE DRILL 1/4 X 12 X 14	1	1
SDS516600	SDS CARBIDE DRILL 5/16 X 4 X 6	1	1
SDS516120	SDS CARBIDE DRILL 5/16 X 10 X 12	1	1
SDS386000	SDS CARBIDE DRILL 3/8 X 4 X 6	1	1
SDS381000	SDS CARBIDE DRILL 3/8 X 8 X 10	1	1
SDS381200	SDS CARBIDE DRILL 3/8 X 10 X 12	1	1
SDS381800	SDS CARBIDE DRILL 3/8 X 16 X 18	1	1
SDS126000	SDS CARBIDE DRILL 1/2 X 4 X 6	1	1
SDS121000	SDS CARBIDE DRILL 1/2 X 8 X 10	1	1
SDS121200	SDS CARBIDE DRILL 1/2 X 10 X 12	1	1
SDS121800	SDS CARBIDE DRILL 1/2 X 16 X 18	1	1
SDS122600	SDS CARBIDE DRILL 1/2 X 24 X 26	1	1
SDS588000	SDS CARBIDE DRILL 5/8 X 6 X 8	1	1
SDS581200	SDS CARBIDE DRILL 5/8 X 10 X 12	1	1
SDS581800	SDS CARBIDE DRILL 5/8 X 16 X 18	1	1
SDS348000	SDS CARBIDE DRILL 3/4 X 6 X 8	1	1
SDS341200	SDS CARBIDE DRILL 3/4 X 10 X 12	1	1
SDS341800	SDS CARBIDE DRILL 3/4 X 16 X 18	1	1

MEDIUM TO LIGHT DUTY MECHANICAL ANCHORS

Strike Anchors



Aerosmith®'s Strike Anchor is a one-piece multi-purpose fastener specifically designed to be used in concrete, brick, grout filled block and stone. The anchor has a pre-expanded bend at the bottom of the anchor which straightens out to conform to the walls of the hole when hammered into the proper size pre-drilled hole. The anchor will always try to regain its preexpanded bend which causes constant expansion pressure within the hole. This eliminates the need for any additional tightening or secondary setting operation. Sizes range from 3/16" diameter to 3/8" and are also available in multiple head styles. The mushroom head version makes an excellent choice for many tamper proof operations.

Sure-Con® Concrete Screws



Aerosmith®'s Sure-Con® Concrete Screws are designed to meet the demands of most light to medium duty applications. The screws are hardened and come with a blue and white environmental coating which allows them to be used in dry interior applications and some exterior applications. The product can be used in concrete, block and brick and manufactured with either a hex washer head or Phillips head. Just pre-drill a hole using a proper size concrete drill bit and run the anchor into the pre-drilled hole. Each box of screws contains one drill bit.

410 Stainless Steel Sure-Cons®



The Aerosmith® Stainless Steel Sure-Con® is a light to medium duty mechanical anchor that is made from 410 Stainless steel. It is available in both a finished Hex head or Phillips head in 3/16 and 1/4 diameters up to 3 3/4 in length. Its properties allow this screw to be used in internal applications but can also be used in some external applications where applicable. The product is designed to be used in concrete, brick and block and requires installation using a Sure-Con® drill bit for maximum performance. A drill bit is included in each box of screws. Installation is fast and easy, just predrill your hole using the proper Sure-Con® drill bit to the required depth and run your screw through your fixture either using a cordless/corded screw gun or impact using the required torque value.

Sure-Con® Concrete Screw Carbide Bits



Sure-Con® Carbide Concrete Bits for 3/16" and 1/4" concrete screws. (Blue and White)

Concrete Hangerz



Aerosmith®'s Concrete Hangerz are designed for suspending threaded rod vertically overhead for pipe hanging, fire protection, electrical conduit and cable tray applications. The one-piece design makes it easy to install and is available with three different coupler sizes. Just drill the same diameter hole as the anchor body and run the anchor into pre-drilled hole using a corded or cordless impact wrench or a standard hand socket.

Wood Vertical Hangerz



Aerosmith®'s Wood Vertical Hangerz are a one-piece, all steel threaded fastening system for suspending steel threaded rod vertically overhead in pipe hanging, fire protection, electrical conduit and cable-tray applications. Parts come with a #17 Point for fast drilling into wood beams. Can be installed with a screw gun or hammer drill in rotation mode only.

Steel Vertical Hangerz

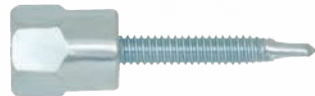

Aerosmith®'s Steel Vertical Hangerz are an all steel fastening system that is used for suspending threaded rod vertically for pipe hanging, fire protection, electrical conduit and cable tray applications. The anchor is easy to install by just running the parts with a screw gun or hammer drill in rotation only mode. It is recommended the parts be installed using the Aerosmith® universal socket.

Zinc & SS Nail-ins



Aerosmith®'s Zinc Nail-in Anchor is a light duty tamper proof anchor whose body is made of zinc alloy. The anchor can be purchased with either a carbon steel nail or a stainless steel nail depending on the application. The zinc nail-in can be used in concrete, block, brick and stone and is easy to install. Pre-drill the same diameter hole as the anchor body, position fixture in place, tap anchor into the pre-drilled hole, when flush, hammer the nail into the body of the anchor. Since the anchor body is made of zinc alloy, it is corrosive resistant when used in conjunction with the stainless steel nail. This anchor should not be used in overhead applications.

Split Anchor Drive



Aerosmith®'s Split Drive anchor is a one piece, all steel mechanical anchor that can be used in concrete, brick, and stone. Its available in a 1/4 diameter, up to 4 inches in length. It comes with a flat head, aka counter sunk and is ideal for applications where the fastening needs to either be permanent or tamper proof. It also works extremely well in wood to concrete connections. Just drill a hole the same diameter as the anchor and hammer it through your fixture and into the base material. It is that simple.

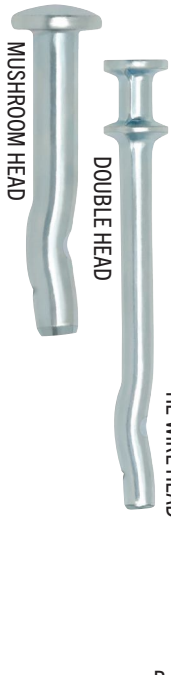

Strike Anchors

Aerosmith®'s Strike Anchor is a one-piece multi-purpose fastener specifically designed to be used in concrete, brick, grout filled block and stone. The anchor has a pre-expanded bend at the bottom of the anchor which straightens out to conform to the walls of the hole when hammered into the proper size pre-drilled hole. The anchor will always try to regain its pre-expanded bend which causes constant expansion pressure within the hole. This eliminates the need for any additional tightening or secondary setting operation. Sizes range from 3/16" diameter to 3/8" and are also available in multiple head styles. The mushroom head version makes an excellent choice for many tamper proof applications.

APPLICATIONS:

- Pipe hanging
- Cable trays
- Metal track to concrete
- Security fixtures
- Concrete formwork
- Bicycle racks
- HVAC straps
- Electrical boxes
- Signage

FEATURES & BENEFITS:

- One-piece pre-expanding anchor
- Tamper resistant (flat and mushroom head)
- No secondary setting operation
- Hole size is the same as anchor size
- No special tools required

BASE MATERIAL:

- Concrete
- Brick
- Grout filled block
- Stone

ANCHOR COMPONENT MATERIALS:

Anchor Body AISI 1038 Carbon Steel, Zinc Plated

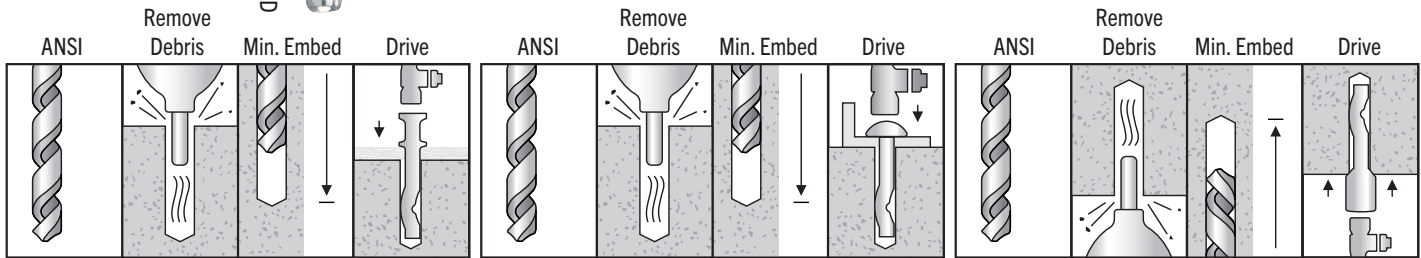

DOUBLE HEAD STRIKE

MUSHROOM HEAD STRIKE

INTERNALLY THREADED STRIKE

Part ID	Product Name	Description	Overall Length	Diameter	MUST USE ANSI Drill Bit	Min. Embed	Box Quantity	Carton Quantity
SPM316100	Zinc Strike	3/16" X 1" (Mushroom Head)	1"	3/16"	3/16"	7/8"	100	1200
SPM316114	Zinc Strike	3/16" X 1-1/4" (Mushroom Head)	1-1/4"	3/16"	3/16"	7/8"	100	1200
SPM316112	Zinc Strike	3/16" X 1-1/2" (Mushroom Head)	1-1/2"	3/16"	3/16"	1-1/4"	100	1200
SPM316200	Zinc Strike	3/16" X 2" (Mushroom Head)	2"	3/16"	3/16"	1-1/4"	100	1200
SPM316212	Zinc Strike	3/16" X 2-1/2" (Mushroom Head)	2-1/2"	3/16"	3/16"	1-1/4"	100	1200
SPM316300	Zinc Strike	3/16" X 3" (Mushroom Head)	3"	3/16"	3/16"	1-1/4"	100	800
SPM316400	Zinc Strike	3/16" x 4" (Mushroom Head)	4"	3/16"	3/16"	1-1/4"	100	800
SPM141000	Zinc Strike	1/4" X 1" (Mushroom Head)	1"	1/4"	1/4"	7/8"	100	1200
SPM141140	Zinc Strike	1/4" X 1-1/4" (Mushroom Head)	1-1/4"	1/4"	1/4"	1"	100	1200
SPM141120	Zinc Strike	1/4" X 1-1/2" (Mushroom Head)	1-1/2"	1/4"	1/4"	1-1/4"	100	1200
SPM142000	Zinc Strike	1/4" X 2" (Mushroom Head)	2"	1/4"	1/4"	1-1/4"	100	800
SPM142120	Zinc Strike	1/4" X 2-1/2" (Mushroom Head)	2-1/2"	1/4"	1/4"	1-1/4"	100	800
SPM143000	Zinc Strike	1/4" X 3" (Mushroom Head)	3"	1/4"	1/4"	1-1/4"	100	800
SPM143120	Zinc Strike	1/4" X 3-1/2" (Mushroom Head)	3-1/2"	1/4"	1/4"	1-1/4"	100	800
SPM144000	Zinc Strike	1/4" X 4" (Mushroom Head)	4"	1/4"	1/4"	1-1/4"	100	800
SPM382000	Zinc Strike	3/8" x 2" (Mushroom Head)	2"	3/8"	3/8"	1-3/4"	25	300
SPM382120	Zinc Strike	3/8" X 2-1/2" (Mushroom Head)	2-1/2"	3/8"	3/8"	1-3/4"	25	300
SPM383000	Zinc Strike	3/8" X 3" (Mushroom Head)	3"	3/8"	3/8"	1-3/4"	25	300
SPM384000	Zinc Strike	3/8" X 4" (Mushroom Head)	4"	3/8"	3/8"	1-3/4"	25	200
SPM385000	Zinc Strike	3/8" X 5" (Mushroom Head)	5"	3/8"	3/8"	1-3/4"	25	150
STW316	Strike	3/16" (Tie Wire Head)	1-1/8"	3/16"	3/16"	1-1/4"	100	800
STW140	Strike	1/4" (Tie Wire Head)	1-1/8"	1/4"	1/4"	1-1/4"	100	800
SPF316112	Double Head Strike	3/16" X 1-1/2"	1-1/2"	3/16"	3/16"	1-1/4"	100	1200
SPF316200	Double Head Strike	3/16" X 2"	2"	3/16"	3/16"	1-1/4"	100	800
SPF316234	Double Head Strike	3/16" X 2-3/4"	2-3/4"	3/16"	3/16"	1-1/4"	100	600
SPF142340	Double Head Strike	1/4" X 2-3/4"	2-3/4"	1/4"	1/4"	1-1/4"	100	600
SPP14	Strike Internally Threaded	1/4" body with 1/4" Coupler	1-1/4"	1/4"	1/4"	1-1/4"	100	1200
SPP38	Strike Internally Threaded	1/4" body with 3/8" Coupler	1-3/4"	1/4"	1/4"	1-3/4"	50	400



Sure-Con[®] Concrete Screws

Miami Dade Approved NOA No. 21-0830.01 July 22, 2026
 Tested in accordance with AC 193, AC 106, AC 233, AC 257 criteria



Aerosmith[®]'s Sure-Con[®] Concrete Screws are designed to meet the demands of most light to medium duty applications. The screws are hardened and come with a blue or white environmental coating which allows them to be used in dry interior applications and some exterior applications. The product can be used in concrete, block and brick and manufactured with either a hex washer head or phillips head. Just pre-drill a hole using a proper size concrete drill bit and run anchor into pre-drill hole. Each box of screws contains one drill bit.

APPLICATIONS:

- Metal door frames
- Window installations
- Shutters
- Joint flashings
- Electrical boxes
- Light fixtures
- Signage
- Electrical junction boxes
- Conduit clips to masonry.
- Wood headers/furring strips to masonry
- HVAC straps to masonry
- Plywood to masonry
- Exterior insulation to masonry

FEATURES & BENEFITS:

- Available in both slotted hex head and phillips flat head
- No hole spotting required
- Product cuts its own threads into masonry
- Coating reduces corrosion
- Can be used in light to medium duty applications

BASE MATERIAL:

- Concrete
- Masonry

ANCHOR COMPONENT MATERIALS:

Body- Heat treated Carbon Steel, Coating- Environmental (Blue)

HEAD STYLES:

Phillips



Slotted Hex Head



PHILLIPS HEAD

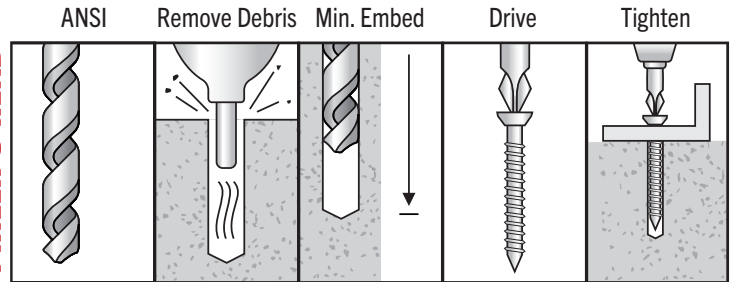

HEX HEAD

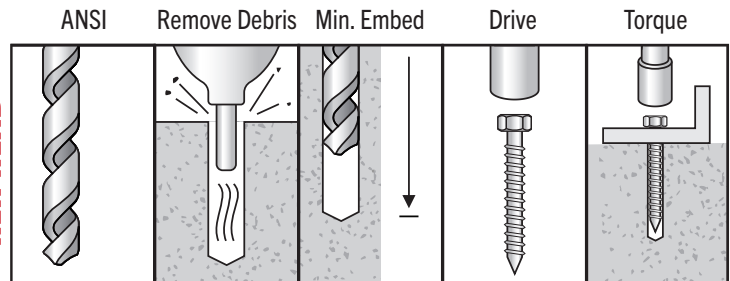

Part ID	Description	Overall Length	Diameter	Min. Embed	Drill Bit	Box Quantity	Carton Quantity
TCH316114*	3/16" X 1-1/4"	1-1/4"	3/16"	1-1/4"	5/32"	100	500
TCH316134*	3/16" X 1-3/4"	1-3/4"	3/16"	1-1/4"	5/32"	100	500
TCH316214	3/16" X 2-1/4"	2-1/4"	3/16"	1-1/4"	5/32"	100	500
TCH316234	3/16" X 2-3/4"	2-3/4"	3/16"	1-1/4"	5/32"	100	500
TCH316314	3/16" X 3-1/4"	3-1/4"	3/16"	1-1/4"	5/32"	100	500
TCH316334	3/16" X 3-3/4"	3-3/4"	3/16"	1-1/4"	5/32"	100	500
TCH316400	3/16" X 4"	4"	3/16"	1-1/4"	5/32"	100	500
TCH141140*	1/4" X 1-1/4"	1-1/4"	1/4"	1-1/4"	3/16"	100	500
TCH141340	1/4" X 1-3/4"	1-3/4"	1/4"	1-1/4"	3/16"	100	500
TCH142140	1/4" X 2-1/4"	2-1/4"	1/4"	1-1/4"	3/16"	100	500
TCH142340	1/4" X 2-3/4"	2-3/4"	1/4"	1-1/4"	3/16"	100	500
TCH143140	1/4" X 3-1/4"	3-1/4"	1/4"	1-1/4"	3/16"	100	500
TCH143340	1/4" X 3-3/4"	3-3/4"	1/4"	1-1/4"	3/16"	100	500
TCH144000	1/4" X 4"	4"	1/4"	1-1/4"	3/16"	100	500

*This size is less than required minimum standard anchor length for strength design

Part ID	Description	Overall Length	Diameter	Min. Embed	Drill Bit	Box Quantity	Carton Quantity
TCP316114*	3/16" X 1-1/4"	1-1/4"	3/16"	1-1/4"	5/32"	100	500
TCP316134*	3/16" X 1-3/4"	1-3/4"	3/16"	1-1/4"	5/32"	100	500
TCP316214	3/16" X 2-1/4"	2-1/4"	3/16"	1-1/4"	5/32"	100	500
TCP316234	3/16" X 2-3/4"	2-3/4"	3/16"	1-1/4"	5/32"	100	500
TCP316314	3/16" X 3-1/4"	3-1/4"	3/16"	1-1/4"	5/32"	100	500
TCP316334	3/16" X 3-3/4"	3-3/4"	3/16"	1-1/4"	5/32"	100	500
TCP316400	3/16" X 4"	4"	3/16"	1-1/4"	5/32"	100	500
TCP141140*	1/4" X 1-1/4"	1-1/4"	1/4"	1-1/4"	3/16"	100	500
TCP141340*	1/4" X 1-3/4"	1-3/4"	1/4"	1-1/4"	3/16"	100	500
TCP142140	1/4" X 2-1/4"	2-1/4"	1/4"	1-1/4"	3/16"	100	500
TCP142340	1/4" X 2-3/4"	2-3/4"	1/4"	1-1/4"	3/16"	100	500
TCP143140	1/4" X 3-1/4"	3-1/4"	1/4"	1-1/4"	3/16"	100	500
TCP143340	1/4" X 3-3/4"	3-3/4"	1/4"	1-1/4"	3/16"	100	500
TCP144000	1/4" X 4"	4"	1/4"	1-1/4"	3/16"	100	500
TCP145000	1/4" X 5"	5"	1/4"	1-1/4"	3/16"	100	500
TCP146000	1/4" X 6"	6"	1/4"	1-1/4"	3/16"	100	500

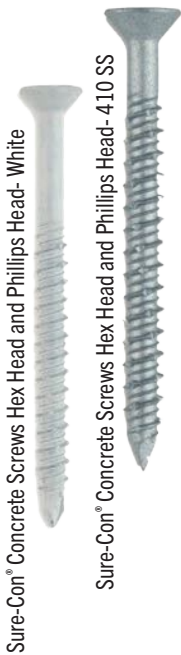

410 Stainless Steel Sure-Cons®

Tested in accordance with AC 193, AC 106, AC 233, AC 257 criteria



Aerosmith®'s Stainless Steel Sure-Con® is a light to medium duty mechanical anchor that is made from 410 Stainless steel. It is available in both a finished Hex head or Phillips head in 3/16 and 1/4 diameters up to 3 3/4 in length. Its properties allow this screw to be used in internal applications but can also be used in some external applications where applicable. The product is designed to be used in concrete, brick and block and requires installation using a Sure-Con® drill bit for maximum performance. A drill bit is included in each box of screws. Installation is fast and easy, just predrill your hole using the proper Sure-Con® drill bit to the required depth and run your screw through your fixture either using a cordless/corded screw gun or impact using the required torque value.

APPLICATIONS:

- Metal door frames
- Window installations
- Shutters
- Joint flashings
- Electrical boxes
- Light fixtures
- Signage
- Electrical junction boxes
- Conduit clips to masonry.
- Wood headers/furring strips to masonry
- HVAC straps to masonry
- Plywood to masonry
- Exterior insulation to masonry

FEATURES & BENEFITS:

- Available in both slotted hex head and phillips flat head
- No hole spotting required
- Product cuts its own threads into masonry
- Coating reduces corrosion
- Can be used in light to medium duty applications

ANCHOR COMPONENT MATERIALS:

- Body- Heat treated Carbon Steel
- Coating- Environmental (410 SS and White)

BASE MATERIAL:

- Masonry

HEAD STYLES:

Phillips



Hex Head

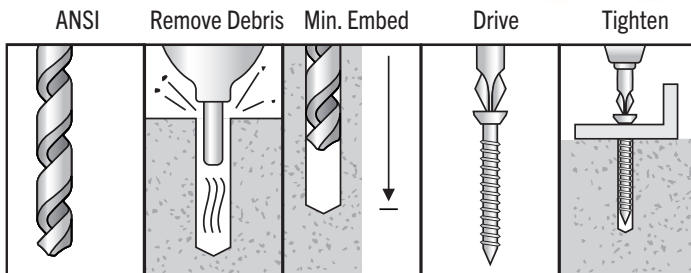

PHILLIPS HEAD

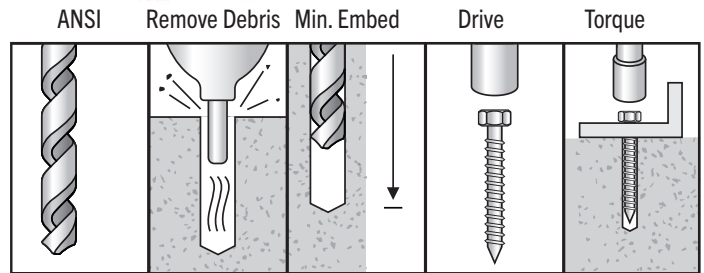

HEX HEAD

Sure-Con® Concrete Screws Hex Head - White & Stainless Steel

Part ID	Description	Overall Length	Diameter	Min. Embed	Drill Bit	Total torque	Box Quantity	Carton Quantity
TCH141140W & TCH4SS141140	1/4" x 1-1/4"	1-1/4" *	1/4"	1"	3/16" Sure -Bit	5 ft lbs.	100	500
TCH141340W & TCH4SS141340	1/4" x 1-3/4"	1-3/4" *	1/4"	1-1/4"	3/16" Sure -Bit	5 ft lbs.	100	500
TCH142140W & TCH4SS142140	1/4" x 2-1/4"	2-1/4" *	1/4"	1-1/4"	3/16" Sure -Bit	5 ft lbs.	100	500
TCH142340W & TCH4SS142340	1/4" x 2-3/4"	1-1/4" *	1/4"	1-1/4"	3/16" Sure -Bit	5 ft lbs.	100	500
TCH143140W & TCH4SS143140	1/4" x 3-1/4"	3-1/4" *	1/4"	1-1/4"	3/16" Sure -Bit	5 ft lbs.	100	500
TCH143340W & TCH4SS143340	1/4" x 3-3/4"	3-3/4" *	1/4"	1-1/4"	3/16" Sure -Bit	5 ft lbs.	100	500
TCH316114W & TCH4SS316114	3/16" x 1-1/4"	1-1/4" *	3/16"	1-1/4"	5/32" Sure -Bit	3 ft lbs.	100	500
TCH316134W	3/16" x 1-3/4"	1-3/4" *	3/16"	1-1/4"	5/32" Sure -Bit	3 ft lbs.	100	500
TCH316214W & TCH4SS316214	3/16" x 2-1/4"	2-1/4" *	3/16"	1-1/4"	5/32" Sure -Bit	3 ft lbs.	100	500
TCH316234W & TCH4SS316234	3/16" x 2-3/4"	2-3/4" *	3/16"	1-1/4"	5/32" Sure -Bit	3 ft lbs.	100	500
TCH316314W	3/16" x 3-1/4"	3-1/4" *	3/16"	1-1/4"	5/32" Sure -Bit	3 ft lbs.	100	500

Sure-Con® Concrete Screws Phillips Head - White & Stainless Steel

Part ID	Description	Overall Length	Diameter	Min. Embed	Drill Bit	Total torque	Box Quantity	Carton Quantity
TCP141140W & TCP4SS141140	1/4" x 1-1/4"	1-1/4" *	1/4"	1"	3/16" Sure -Bit	5 ft lbs.	100	500
TCP141340W & TCP4SS141340	1/4" x 1-3/4"	1-3/4" *	1/4"	1-1/4"	3/16" Sure -Bit	5 ft lbs.	100	500
TCP142140W & TCP4SS142140	1/4" x 2-1/4"	2-1/4" *	1/4"	1-1/4"	3/16" Sure -Bit	5 ft lbs.	100	500
TCP142340W & TCP4SS142340	1/4" x 2-3/4"	1-1/4" *	1/4"	1-1/4"	3/16" Sure -Bit	5 ft lbs.	100	500
TCP143140W & TCP4SS143140	1/4" x 3-1/4"	3-1/4" *	1/4"	1-1/4"	3/16" Sure -Bit	5 ft lbs.	100	500
TCP144000W	1/4" x 4"	4"	1/4"	1-1/4"	3/16" Sure -Bit	5 ft lbs.	100	500
TCP316114W & TCP4SS316114	3/16" x 1-1/4"	1-1/4" *	3/16"	1-1/4"	5/32" Sure -Bit	3 ft lbs.	100	500
TCP316134W & TCP4SS316134	3/16" x 1-3/4"	1-3/4" *	3/16"	1-1/4"	5/32" Sure -Bit	3 ft lbs.	100	500
TCP316214W & TCP4SS316214	3/16" x 2-1/4"	2-1/4" *	3/16"	1-1/4"	5/32" Sure -Bit	3 ft lbs.	100	500
TCP316234W & TCP4SS316234	3/16" x 2-3/4"	2-3/4" *	3/16"	1-1/4"	5/32" Sure -Bit	3 ft lbs.	100	500
TCP316314W	3/16" x 3-1/4"	3-1/4" *	3/16"	1-1/4"	5/32" Sure -Bit	3 ft lbs.	100	500

Sure-Con® Concrete Screw Carbide Bits

Sure-Con® Concrete Screw Bits are to be used for the installation of Aerosmith®'s 1/4" - 3/16" concrete screws.

Part ID	Description	Diameter	Overall Length	Bag	Carton Quantity
CSB532312	Concrete Screw Bits 5/32" X 3-1/2"	3-1/2"	5/32"	10 per bag	50
CSB532412	Concrete Screw Bits 5/32" X 4-1/2"	4-1/2"	5/32"	10 per bag	50
CSB532512	Concrete Screw Bits 5/32" X 5-1/2"	5-1/2"	5/32"	10 per bag	50
CSB316312	Concrete Screw Bits 3/16" X 3-1/2"	3-1/2"	3/16"	10 per bag	50
CSB316412	Concrete Screw Bits 3/16" X 4-1/2"	4-1/2"	3/16"	10 per bag	50
CSB316512	Concrete Screw Bits 3/16" X 5-1/2"	5-1/2"	3/16"	10 per bag	50
CSB316612	Concrete Screw Bits 3/16" X 6-1/2"	6-1/2"	3/16"	10 per bag	50
CSB316712	Concrete Screw Bits 3/16" X 7-1/2"	7-1/2"	3/16"	10 per bag	50





Concrete Hangerz

Aerosmith®'s Concrete Hangerz are designed for suspending threaded rod vertically overhead for pipe hanging fire protection, electrical conduit and cable tray applications. The one-piece design makes it easy to install and is available with three different coupler sizes. Just drill the same diameter hole as the anchor body and run the anchor into pre-drilled hole using a corded or cordless impact wrench or standard hand socket.

APPLICATIONS:

- Suspended ceilings
- Cable trays
- Overhead utilities
- Air conditioning
- Ventilation systems
- Lighting systems

FEATURES & BENEFITS:

- Quick installation time
- Stress applied across full length of anchor
- Can be installed close to edge applications
- Fully removable

BASE MATERIAL:

- Stone
- Concrete
- Block
- Brick

ANCHOR COMPONENT MATERIALS:

- Carbon Steel - with Zinc plating

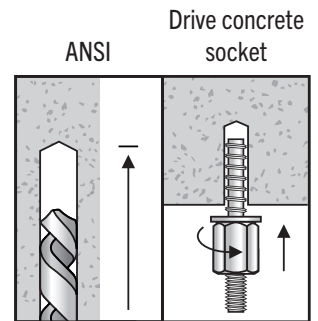

Part ID	Description	Usable Length	Diameter	Insert Rod	Box Quantity	Carton Quantity
VHC1411414	Concrete Hanger 1/4" x 1-1/4" with 1/4" Coupler	1-1/4"	1/4"	Insert 1/4" Rod	25	250
VHC1411238	Concrete Hanger 1/4" x 1-1/2" with 3/8" Coupler	1-1/2"	1/4"	Insert 3/8" Rod	25	250
VHC3823412	Concrete Hanger 3/8" x 2-3/4" with 1/2" Coupler	2-3/4"	3/8"	Insert 1/2" Rod	25	200

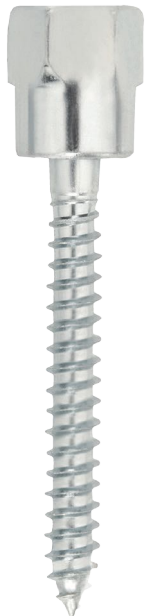

Wood Vertical Hangerz

Aerosmith®'s Wood Vertical Hangerz is an all steel threaded fastener used for suspending threaded rod in wood base materials. The anchor is easy to install by running the parts with a screw gun or hammer drill in rotation only mode. It is recommended the parts be installed using the Aerosmith® socket.

APPLICATIONS:

- Hanging Pipe and Sprinkler Systems
- Lighting Systems and Overhead Utilities
- Suspended Ceilings
- Suspending Conduit
- Cable Trays
- HVAC Ductwork
- Strut Channels
- Security Equipment

FEATURES & BENEFITS:

- Quick installation time
- Stress applied across full length of anchor
- Can be installed close to edge applications
- Fully removable

BASE MATERIAL:

- Wood frame columns
- Wood frame beams

ANCHOR COMPONENT MATERIALS:

Zinc Plated Carbon Steel #17 Point

Part ID	Description	Usable Length	Diameter	Insert Rod	Box Quantity	Carton Quantity
VHW14214	Wood Hanger 1/4" x 2" with 1/4" Coupler	2"	1/4"	Insert 1/4" Rod	25	250
VHW14238	Wood Hanger 1/4" x 2" with 3/8" Coupler	2"	3/8"	Insert 3/8" Rod	25	250
VHW51621238	Wood Hanger 5/16" x 2-1/2" with 3/8" Coupler	2-1/2"	3/8"	Insert 3/8" Rod	25	250

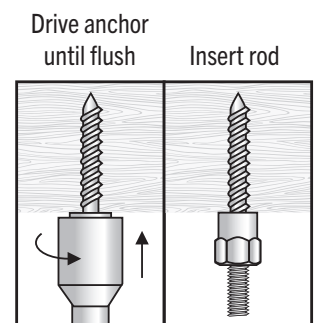



Steel Vertical Hangerz

Aerosmith®'s Steel Vertical Hangerz are an all steel fastening system that is used for suspending threaded rod vertically for pipe hanging, fire protection, electrical conduit and cable tray applications. The anchor is easy to install by just running the parts with a screw gun or hammer drill in rotation only mode. It is recommended the parts be installed using the Aerosmith® socket.

APPLICATIONS:

- Hanging pipe and sprinkler systems
- Lighting systems and overhead utilities
- Suspended ceilings
- Suspending conduit
- Cable trays
- HVAC ductwork
- Strut channels
- Security equipment

FEATURES & BENEFITS:

- Rod hanging application system in steel
- Rapid installation for overhead applications
- Steel Hangerz can be installed with a hammer drill (rotation only) or screw gun

BASE MATERIAL:

- Steel bar joists
- Wood column
- Steel beams

ANCHOR COMPONENT MATERIALS:

Zinc Plated Carbon Steel #3 Point

Part ID	Description	Usable Length	Diameter	Insert Rod	Box Quantity	Carton Quantity
VHS14114	Steel Hanger 1/4" x 1" with 1/4" Coupler	1"	1/4"	Insert 1/4" Rod	25	250
VHS14138WN	Steel Hanger 1/4" x 1" w/nut-3/8" Coupler	1"	3/8"	Insert 3/8" Rod	25	250
VHS1411238N	Steel Hanger 1/4" x 1-1/2" w/nut-3/8" Coupler	1-1/2"	3/8"	Insert 3/8" Rod	25	250
VHS122011238N	Steel Hanger 12- 20 x 1-1/2" w/nut-1/2" Coupler	1-1/2"	1/2"	Insert 1/2" Rod	25	250

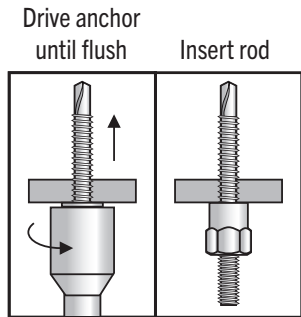

Sockets

Part ID	Description	Box Quantity	Carton Quantity
US1	Steel & Wood Socket	5	25
CS14	1/4" Concrete Socket	5	25
CS38	3/8" Concrete Socket	5	25
CS12	1/2" Concrete Socket	5	25



Socket for Steel & Wood



Concrete Socket

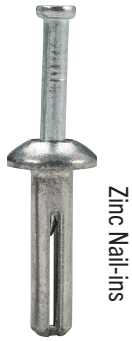

Zinc Nail-ins

Zinc Nail-in Anchors

Aerosmith®'s Zinc Nail-in Anchor is a light duty tamper proof anchor whose body is made of zinc alloy. The anchor can be purchased with either a carbon steel nail or a stainless steel nail depending on the application. The zinc nail-in can be used in concrete, block, brick and stone and is easy to install. Predrill the same diameter hole as the anchor body, position fixture in place, tap anchor into the pre-drilled hole, when flush, hammer the nail into the body of the anchor. Since the anchor body is made of zinc alloy, it is corrosive resistant when used in conjunction with the stainless steel nail. This anchor should not be used in overhead applications.

APPLICATIONS:

- Drywall track
- Light duty signage
- Brick ties
- Parapet flashing

FEATURES & BENEFITS:

- Fast installation
- Nails available in stainless steel
- No special tools needed
- Can be used in a variety of base materials
- Flush appearance when properly set
- Available in removable version

BASE MATERIAL:

- Concrete
- Brick
- Block
- Stone



SS Nail-ins

ANCHOR COMPONENT MATERIALS:

- Zinc Zamac Alloy (Body)
- Carbon Steel (Nail) AISI 1018
- Stainless Steel (Nail) Type 304 SS

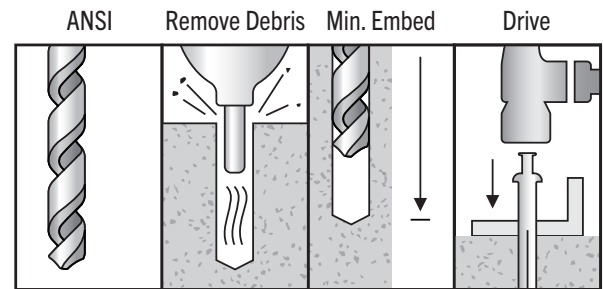

Part ID	Product Name	Description	Overall Length	Overall Diameter	ANSI Drill Diameter	Min. Embed	Box Quantity	Carton Quantity
ZNMH31678	Zinc Nail-In	3/16 X 7/8 (Mushroom Head)	7/8"	3/16"	3/16"	3/4"	100	500
ZNMH1434	Zinc Nail-In	1/4 X 3/4 (Mushroom Head)	3/4"	1/4"	1/4"	5/8"	100	500
ZNMH141	Zinc Nail-In	1/4 X 1 (Mushroom Head)	1"	1/4"	1/4"	7/8"	100	500
ZNMH14114	Zinc Nail-In	1/4 X 1 1/4 (Mushroom Head)	1-1/4"	1/4"	1/4"	1"	100	500
ZNMH14112	Zinc Nail-In	1/4 X 1 1/2 (Mushroom Head)	1-1/2"	1/4"	1/4"	1-1/4"	100	500
ZNMH142	Zinc Nail-In	1/4 X 2 (Mushroom Head)	2"	1/4"	1/4"	1-1/2"	100	500
ZNMH143	Zinc Nail-In	1/4 X 3 (Mushroom Head)	3"	1/4"	1/4"	2-1/2"	100	500

Part ID	Product Name	Description	Overall Length	Overall Diameter	ANSI Drill Diameter	Min. Embed	Box Quantity	Carton Quantity
ZNMHSS141	SS Nail-In	1/4 X 1 (Mushroom Head)	1"	1/4"	1/4"	7/8"	100	500
ZNMHSS14114	SS Nail-In	1/4 X 1 1/4 (Mushroom Head)	1-1/4"	1/4"	1/4"	1"	100	500
ZNMHSS14112	SS Nail-In	1/4 X 1 1/2 (Mushroom Head)	1-1/2"	1/4"	1/4"	1-1/4"	100	500
ZNMHSS142	SS Nail-In	1/4 X 2 (Mushroom Head)	2"	1/4"	1/4"	1-1/2"	100	500



Removable Zinc Nail-in Anchors

Aerosmith®'s Removable Zinc Nail-In Anchor is a medium to light duty anchor whose body is made of zinc alloy and its screw made of carbon steel. Unlike the standard zinc nail-in, this product comes with a screw rather than a nail so that once installed, it can be removed. The product can be used in concrete, brick, block and stone and is easy to install. Pre-drill the same diameter hole as the anchor body, position fixture in place, tap anchor into pre-drilled hole. When flush, hammer the head of the screw into the body of the anchor. To remove, just back out the screw to release the expansion mechanism. This anchor should not be used in overhead applications.

APPLICATIONS:

- Drywall track
- Light duty signage
- Brick ties
- Parapet flashing

FEATURES & BENEFITS:

- Fast installation
- Nails available in stainless steel
- No special tools needed
- Can be used in a variety of base materials
- Flush appearance when properly set
- Available in removable version

BASE MATERIAL:

- Concrete
- Brick
- Block
- Stone

ANCHOR COMPONENT MATERIALS:

- Zinc Zamac Alloy (Body)
- Carbon Steel (Screws)

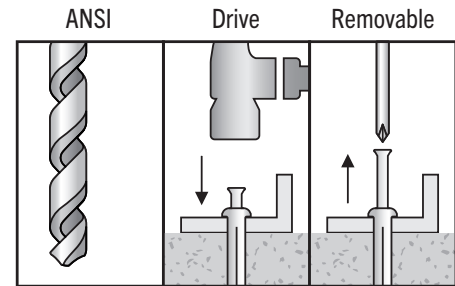

Part ID	Product Name	Description	Overall Length	Overall Diameter	ANSI Drill Diameter	Min. Embed	Box Quantity	Carton Quantity
ZNHS1434	Removable Zinc Nail-In	1/4 X 3/4"	3/4"	1/4"	1/4"	5/8"	100	500
ZNHS141	Removable Zinc Nail-In	1/4 X 1"	1"	1/4"	1/4"	7/8"	100	500
ZNHS14114	Removable Zinc Nail-In	1/4 X 1-1/4"	1-1/4"	1/4"	1/4"	1"	100	500
ZNHS14112	Removable Zinc Nail-In	1/4 X 1-1/2"	1-1/2"	1/4"	1/4"	1-1/4"	100	500
ZNHS142	Removable Zinc Nail-In	1/4 X 2"	2"	1/4"	1/4"	1-1/2"	100	500
ZNHS143	Removable Zinc Nail-In	1/4 X 3"	3"	1/4"	1/4"	2-1/2"	100	500



Split Drive Anchor

Aerosmith®'s Split Drive anchor is a one piece, all steel mechanical anchor that can be used in concrete, brick, and stone. Its available in a 1/4 diameter, up to 4 inches in length. It comes with a flat head, aka counter sunk and is ideal for applications where the fastening needs to either be permanent or tamper proof. It also works extremely well in wood to concrete connections. Just drill a hole the same diameter as the anchor and hammer it through your fixture and into the base material. It is that simple.

APPLICATIONS:

- Drywall track
- Light duty signage
- Brick ties
- Parapet flashing

FEATURES & BENEFITS:

- Fast installation
- No special tools needed
- Can be used in a variety of base materials
- Flush appearance when properly set

BASE MATERIAL:

- Concrete
- Brick
- Block
- Stone

ANCHOR COMPONENT MATERIALS:

- Carbon Steel
- Heat Treated

Part ID	Product Name	ANSI Drill Diameter	Diameter	Min. Embed	Box Quantity	Carton Quantity
SDA142000	Split Drive Anchor 1/4" x 2" (Flathead)	2"	1/4"	1-1/8"	100	800
SDA143000	Split Drive Anchor 1/4" x 3" (Flathead)	3"	1/4"	1-1/8"	100	800
SDA144000	Split Drive Anchor 1/4" x 4" (Flathead)	4"	1/4"	1-1/8"	100	500



CAST IN PLACE ANCHORS



Blue Banger Hanger™ Steel Deck Insert



Blue Banger Hanger Steel Deck Inserts are installed prior to pouring concrete which reduces installation and material costs and increases strength values. The parts take multiple sizes of threaded rod, have a large flanged head, and a 3" plastic sleeve to help keep threads clean. An installation tool is also available to punch a hole through the metal deck for ease of installation. The parts are also seismically qualified for use in cracked concrete. Installation is quick and easy, punch hole through metal deck – insert blue banger hanger, apply pressure to head of anchor to lock in place and pour concrete.

APPLICATIONS:

- For hanging threaded rod in overhead applications
- Cable trays
- Fire sprinkler pipes
- Suspended conduit
- Suspended ceiling and lighting
- Telecommunication installations
- Water pipes (plumbing)
- HVAC

FEATURES & BENEFITS:

- The Steel Deck Inserts installed height of just 2 inches can be used through or between the ribs of the deck
- Patented grooved insert body prevents component separation even if the flute is broken off prior to pour
- Reduces inventory so three inserts can accommodate five threaded rod sizes
- Allows for threaded rod size changes after inserts are installed
- Internal threads eliminate the need and cost of couplings
- Keeps internal threads clean
- Extended length makes insert easy to locate even with fireproofing on deck underside
- Plastic sleeve provides guidance to align threaded rod with matching internal female threads
- Positions all inserts on the project at the same elevation to eliminate multiple all thread rod lengths and improve the accuracy of offsite prefabrication

APPROVALS:

ICC-ES ESR-3599



All reports listed below are owned by Tomarco /ASAT Construction Supplies

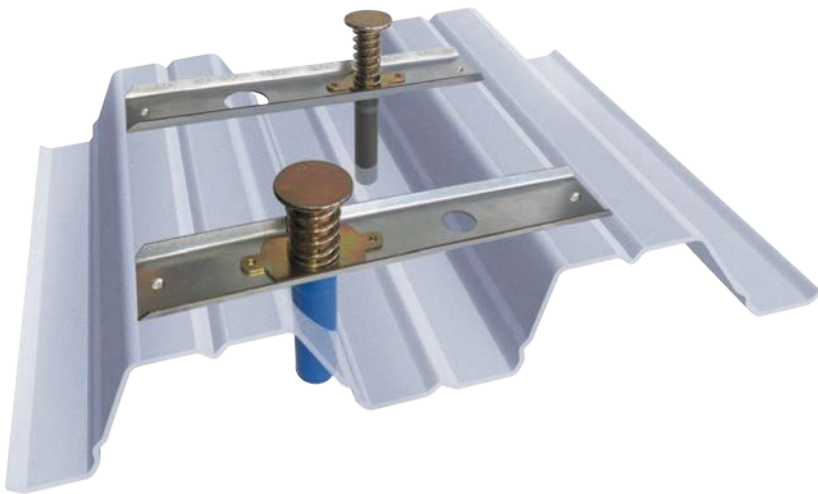

Drill hole in deck
Insert Blue Banger Hanger w/ sleeve down
Step on anchor to lock in place
Insert threaded rod from underneath deck

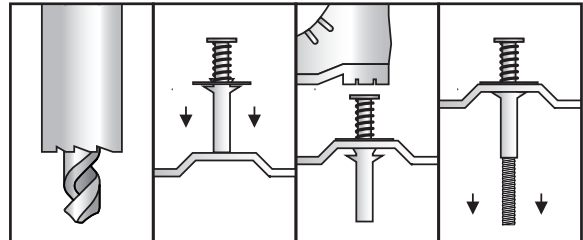

Part ID	Size	Box Quantity
HEA-SD1143812	1/4", 3/8", 1/2"	100
HEA-SD1381258	3/8", 1/2", 5/8"	50
HEA-SD15834	5/8", 3/4"	50
CEABBDP1 Install Tool	1/4" - 3/8"	1
CEABBDP2 Install Tool	3/8" - 5/8"	1
HEA-RDI-143812	Roof Deck Insert	1
HEA-FSBX	New Universal FSB Bracket	1
RDI-2	Roof Deck Insert 2	1
POLMKEY36	Tele. Keyless Chuck Poll 3 ft.-6ft.	1
CEA-SB4	Step Bit For SDI 3/16" - 7/8"	1



CEABBDP1 Install Tool



CEABBDP2 Install Tool



Blue Banger Hanger™ Pour In Place (PIP) Pour-in-Place Insert for the attachment of Threaded Rod

Pour-in-Place Inserts are used on wood form poured decks and installed prior to pouring concrete which reduces installation and material costs. Blue Banger Hanger PIP's are easy to use just strike the top of the hanger and drive the three mounting nails into the forming material until the bottom of the hanger is flush with the plywood. The hanger should be sitting 90 degrees perpendicular to the forming material. Once concrete is hardened, and forms are stripped, strike the mounting nails to break them off, it's that simple.

APPLICATIONS:

- For hanging threaded rod in overhead applications
- Cable trays
- Fire sprinkler pipes
- Suspended conduit
- Suspended ceiling and lighting
- Telecommunication installations
- Water pipes (plumbing)
- HVAC

FEATURES & BENEFITS:

- Provides excellent shear values for overhead attachments
- Reduces inventory so three inserts can accommodate five threaded rod sizes
- Allows for threaded rod size changes after inserts are installed
- Internal threads eliminate the need and cost of couplings
- Blue plastic ring acts as insert locator when forms are removed
- Plastic ring creates countersunk recess to keep threads clean from pour residue

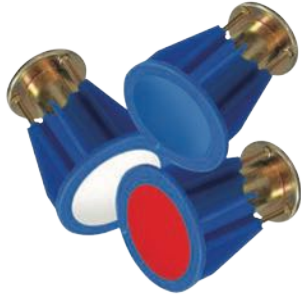

APPROVALS:

ICC-ES ESR-3599



All reports listed below are owned by Tomarco /ISAT Construction Supplies

NEW SLURRY SEAL:

- Slurry seal safeguards the internal threads from concrete during the pour
- Red, white and blue colored slurry seal labels identify the insert when used by multiple trades
- Does not catch rod threads or interfere with rod size changes
- Won't fall out like foam inserts



MULTI-THREAD SUPPORT:

- Multi-thread inserts reduce inventory - Compare to similar products who have as many as five insert sizes, one for each size
- Easily change rod sizes after the install - Not possible with single size inserts
- Slurry seal does not interfere with rod size changes, products that are difficult to break plastic or foam inserts that tangle

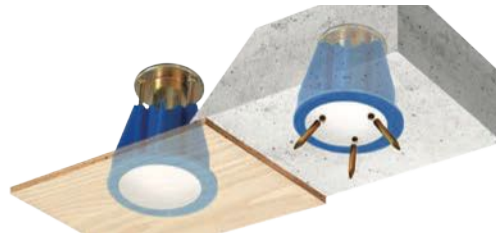

Hammer PIP into wood deck Anchor set in wood form

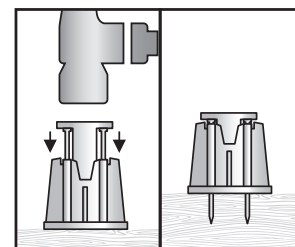

Part ID	Size	Box Quantity
HEA-PIP143812	1/4", 3/8", 1/2"	100
HEA-PIP381258	3/8", 1/2", 5/8"	50
HEA-PIP5834	5/8" - 3/4"	100
CEA-PIPInstallWide Tool	Pour-in-Place Tool Wide	1

CEA-PIPInstallWide Tool



DRYWALL AND HOLLOW CAVITY ANCHORS

Plastic Anchor Kits



Great for many light-duty uses - Install doorbells, curtain rods, pictures, light mirrors, photo frames, lights in drywall, plaster board, gypsum board, brick wall, concrete wall or wood wall. Easy to Install - drill hole, insert the anchor, and place the item against the anchor, then drive the screw through the hole in to the anchor. Designed to prevent problems during installation - ribs prevent anchor from spinning in the hole while tightening the screw. Plastic anchor material protects against rust and corrosion

Toggle Bolts

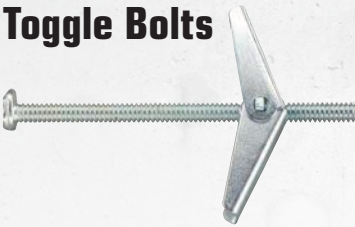

Aerosmith®'s Toggle Bolt is specifically designed to be used in drywall/wallboard and other hollow base materials where expansion anchors typically do not work or perform well. The toggle bolt is a two component system consisting of a machine bolt in either a round, mushroom, or flat head and a spring wing. Sizes range from 1/8" to 1/2" in diameter. A variety of different lengths can be used, depending on the application and thickness of the material, before entering the hollow cavity.

Nylon & Zinc EZ Zip Drywall Anchors



Aerosmith®'s EZ Zip Drywall/Wallboard Anchor is a one piece self-drilling anchor which is manufactured and available in both engineered nylon and zinc alloy. The EZ Zip is specifically designed for use in drywall/wallboard and can be used with either a number #6 or a number #8 sheet metal screw. Anchors can also be ordered with or without screws or in an easy to use EZ Zip kit version. It is intended for use in drywall/wallboard thicknesses of 3/8" to 1".

Nylon Drywall Toggle



Aerosmith®'s Nylon Toggle is a one-piece pre-assembled anchor that can be used in hollow wallboard or hollow block applications. The anchor consists of a carbon steel wing and an engineered plastic strap. Simply fold the wing perpendicular to the strap, push wing through the proper pre-drilled hole, pull back on the strap, and slide the plastic disc against the front of the wall. Snap off the remaining nylon, put fixture in place and screw into the wing using a machine bolt of the proper diameter. By folding the wing perpendicular with the strap, this allows the anchor to be installed into smaller holes than conventional spring wing toggles. Nylon toggles are available in 3/16", 1/4", 3/8", and 1/2" diameters.

Plastic Anchor Kits

Great for many light-duty uses - Install doorbells, curtain rods, pictures, light mirrors, photo frames, lights in drywall, plaster board, gypsum board, brick wall, concrete wall or wood wall. Easy to Install - drill hole, insert the anchor, and place the item against the anchor, then drive the screw through the hole in to the anchor. Designed to prevent problems during installation - ribs prevent anchor from spinning in the hole while tightening the screw. Plastic Anchor material protects against rust and corrosion.



Part ID	Screw Size	Drill Bit Size	Each	Carton	Kit Contains
PAK8X1	8x1 pan head	3/16 x 4"	1	10	100 anchors, 100 screws and 1 drill bit
PAK10X1	10x1 pan head	1/4 x 4"	1	10	100 anchors, 100 screws and 1 drill bit
PAK14X112	14 X 1-1/2 pan head	5/16 x 4"	1	10	50 anchors, 50 screws and 1 drill bit





Toggle Bolts

Aerosmith®'s Toggle Bolt is specifically designed to be used in drywall/wallboard and other hollow base materials where expansion anchors typically do not work or perform well. The toggle bolt is a two component system consisting of a machine bolt in either a round, mushroom, or flat head and a spring wing. Sizes range from 1/8" to 1/2" in diameter. A variety of different lengths can be used, depending on the application and thickness of the material, before entering the hollow cavity.

APPLICATIONS:

- Attachment of insulation
- Suspended ceiling hangers
- Lighting
- TV brackets into hollow base materials
- Picture hanging
- Railings

FEATURES & BENEFITS:

- Adjustable for various wall thicknesses
- Fast and easy installation and removal
- Available in a variety of head styles
- Product made from carbon steel
- Clamps the back of the base material providing resistance.

BASE MATERIAL:

- Drywall
- Hollow block



ANCHOR COMPONENT MATERIALS:

Carbon Steel - Zinc plated

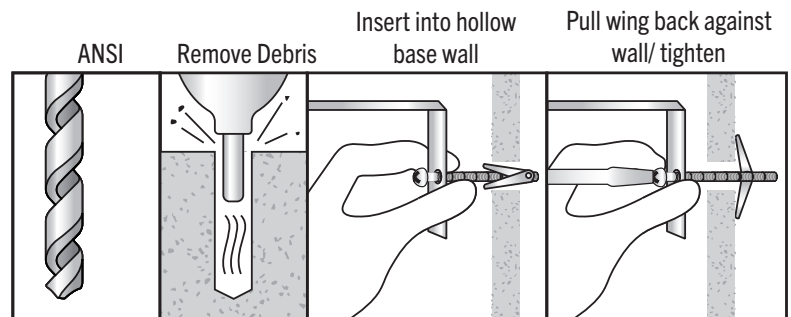

Part ID	Product Name	Description	Overall Length	Diameter	ANSI Drill Diameter	Box Quantity	Carton Quantity
TGMH182	Toggle Bolt Mushroom Head	1/8" X 2"	2"	1/8"	3/8"	50	500
TGMH183	Toggle Bolt Mushroom Head	1/8" X 3"	3"	1/8"	3/8"	50	500
TGMH184	Toggle Bolt Mushroom Head	1/8" X 4"	4"	1/8"	3/8"	50	500
TGMH3163	Toggle Bolt Mushroom Head	3/16" X 3"	3"	3/16"	1/2"	50	500
TGMH3164	Toggle Bolt Mushroom Head	3/16" X 4"	4"	3/16"	1/2"	50	500
TGMH143	Toggle Bolt Mushroom Head	1/4" X 3"	3"	1/4"	5/8"	50	500
TGMH144	Toggle Bolt Mushroom Head	1/4" X 4"	4"	1/4"	5/8"	50	500
TGRH182	Toggle Bolt Round Head	1/8" X 2"	2"	1/8"	3/8"	50	500
TGRH183	Toggle Bolt Round Head	1/8" X 3"	3"	1/8"	3/8"	50	500
TGRH184	Toggle Bolt Round Head	1/8" X 4"	4"	1/8"	3/8"	50	500
TGRH3163	Toggle Bolt Round Head	3/16" X 3"	3"	3/16"	1/2"	50	500
TGRH3164	Toggle Bolt Round Head	3/16" X 4"	4"	3/16"	1/2"	50	500
TGRH3165	Toggle Bolt Round Head	3/16" X 5"	5"	3/16"	1/2"	50	500
TGRH3166	Toggle Bolt Round Head	3/16" X 6"	6"	3/16"	1/2"	50	500
TGRH143	Toggle Bolt Round Head	1/4" X 3"	3"	1/4"	5/8"	50	500
TGRH144	Toggle Bolt Round Head	1/4" X 4"	4"	1/4"	5/8"	50	500
TGRH145	Toggle Bolt Round Head	1/4" X 5"	5"	1/4"	5/8"	50	500
TGRH146	Toggle Bolt Round Head	1/4" X 6"	6"	1/4"	5/8"	50	500
TGRH383	Toggle Bolt Round Head	3/8" X 3"	3"	3/8"	7/8"	25	250
TGRH384	Toggle Bolt Round Head	3/8" X 4"	4"	3/8"	7/8"	25	250
TGRH385	Toggle Bolt Round Head	3/8" X 5"	5"	3/8"	7/8"	25	125
TGRH386	Toggle Bolt Round Head	3/8" X 6"	6"	3/8"	7/8"	25	125
TGFH183	Toggle Bolt Flat Head	1/8" X 3"	3"	1/8"	3/8"	50	500
TGFH3164	Toggle Bolt Flat Head	3/16" X 4"	4"	3/16"	1/2"	50	500
TGFH143	Toggle Bolt Flat Head	1/4" X 3"	3"	1/4"	5/8"	50	500
TGFH144	Toggle Bolt Flat Head	1/4" X 4"	4"	1/4"	5/8"	50	500
TGW18	Toggle Wings	1/8"	N/A	N/A	3/8"	100	500
TGW316	Toggle Wings	3/16"	N/A	N/A	1/2"	100	1000
TGW14	Toggle Wings	1/4"	N/A	N/A	5/8"	100	1000
TGW38	Toggle Wings	3/8"	N/A	N/A	7/8"	50	500



EZ Zip Drywall Anchors

Aerosmith®'s EZ Zip Drywall Anchor is a one-piece self-drilling anchor which is manufactured and available in both engineered nylon and zinc alloy. It is specifically designed for use in dry wall and can be used in wallboard from 3/8" to thickness. Both the nylon and zinc part can be used with a #6 or #8 screw.

APPLICATIONS:

- Electrical fixtures
- Shelving
- Telephone systems
- Curtain poles
- Interior finishing
- Miscellaneous hardware

FEATURES & BENEFITS:

- Fully removable
- No requirement for pre-drilling
- Accurate fixing with tooth design
- Accurate fixing with point design in drywall

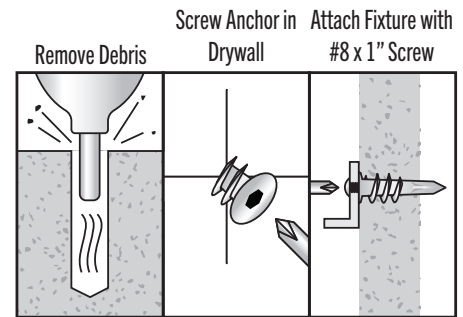

ANCHOR COMPONENT MATERIALS:

- Engineered Nylon
- Zinc Alloy

BASE MATERIAL:

- Drywall / Wallboard

Part ID	Description	Wall Thickness	Screw Size	Box Quantity	Carton Quantity
ZPZ381	Zinc Drywall Anchor 3/8" to 1" w/Screw	3/8" - 1"	#8x1"	100	1000
ZPZ381NS	Zinc Drywall Anchor 3/8" to 1" w/o Screw	3/8" - 1"	#8x1"	100	1000
ZPZ381NSB	Zinc Drywall Anchor 3/8" to 1" w/o Screw	3/8" - 1"	#8x1"	1000	1000
ZPZ381K	Zinc Drywall Anchor 3/8" to 1" Kit	3/8" - 1"	#8x1"	1	10
ZPN381	Nylon Drywall Anchor 3/8" to 1" w/ Screw	3/8" to 1"	#8x1"	100	1000
ZPN381NS	Nylon Drywall Anchor 3/8" to 1" w/o Screw	3/8" to 1"	#8x1"	100	1000
ZPN381B	Nylon Drywall Anchor 3/8" to 1" Bulk	3/8" to 1"	#8x1"	1000	1000
ZPN381K	Nylon Drywall Anchor 3/8" to 1" Kit	3/8" to 1"	#8x1"	1	10



Nylon Drywall Toggle

Aerosmith®'s Nylon Toggle is a one-piece pre-assembled anchor that can be used in hollow wallboard or hollow block applications. The anchor consists of a carbon steel wing and an engineered plastic strap. Simply fold the wing perpendicular to the strap, push wing through the proper pre-drilled hole, pull back on the strap, and slide the plastic disc against the front of the wall. Snap off the remaining nylon, put fixture in place and screw into the wing using a machine bolt of the proper diameter. By folding the wing perpendicular with the strap, this allows the anchor to be installed into smaller holes than conventional spring wing toggles. Nylon toggles are available in 3/16", 1/4", 3/8", and 1/2" diameters.

APPLICATIONS: FEATURES & BENEFITS:

- Towel bars
- Kitchen cabinets
- Bathroom accessories
- Electrical boxes
- Pictures
- Mirrors
- Handrails
- Signage

BASE MATERIAL:

- Drywall
- Hollow block

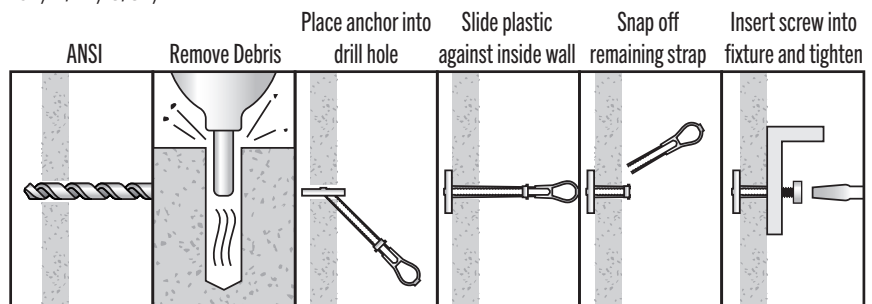

ANCHOR COMPONENT MATERIALS:

Engineered Plastic with a Carbon Steel Wing

Part ID	Description	ANSI Drill Diameter	Box Quantity	Carton Quantity
STG316	3/16" x 4"	1/2"	50	300
STG14	1/4" x 4"	1/2"	50	300
STG38	3/8" x 4"	3/4"	25	150
STG12	1/2" x 4"	3/4"	25	150



ADHESIVE ANCHORING



Aerosmith® Sure-Set Plus+ Pure Epoxy

At Aerosmith® Fastening Systems, your health and safety on the construction site, is job one. That's why we ensure that all the adhesives we sell carry the highly recognized ICC-ES and Lampro Certified Approvals. What this means is that these products have gone through extensive and rigorous testing to not only ensure product quality, but more importantly when used appropriately, perform as intended with your safety and the safety of others at the forefront.



Manufactured in the USA

**BABA:
Buy America,
Build America**

PRODUCT INFORMATION:

The PE-10 Plus+/PE-21 Plus+ is an injectable two component epoxy adhesive. The two components are kept separately by means of a labeled dual cylinder cartridge. The two components combine and react when dispensed through a static mixing nozzle supplied by Aerosmith Fastening Systems, which comes attached to each cartridge. Product is available in a 9.5- and 20.5- fluid ounce cartridge. This high-performance adhesive may be used in combination with a Manual, Battery or Pneumatic Dispensing Tool. It was specifically designed for the anchoring of threaded rods and reinforcing bars into Normal and Light weight concrete, brick, block and stone.



APPLICATIONS:

- Structural applications in cracked and uncracked concrete
- Pinning building façades
- Post installed rebar connections
- Crash barriers
- The attachment of structural steel to concrete
- Railings
- Signage
- Rebar doweling
- Sill plate attachments: suitable for horizontal, vertical and overhead anchoring applications.
- Cable trays
- Lighting Stanchions
- Conveyors
- Racking

BASE MATERIALS:

- Concrete
- Hard natural stone
- Solid rock
- Solid masonry

Part ID	Product	Cartridge size	Carton Quantity
Sure-Set PE-10 Plus+	Sure-Set® PE-10 Plus+	10 oz (8.5 fluid ounces)	12
Sure-Set PE-21 Plus+	Sure-Set® PE-21 Plus+	21 oz (21 fluid ounces)	12

IMPORTANT INFORMATION:

- ICC-ES Evaluated ESR-5901
- Two year shelf life when stored properly
- Certificated through WQA's Gold Seal program for drinking water system components
- For heavy anchoring and post-installed rebar connection
- Seismic rated
- Can be applied in dry, wet, submerged concrete or water filled bore holes
- High chemical resistance
- Low odor
- High bending and pressure strength
- Cartridge can be reused up to the end of the shelf life by either replacing the static mixer or resealing cartridge with the sealing cap

APPROVALS AND LISTING:

ICC-ES ESR-5901 Cracked and Uncracked Concrete Category 1
 Code Compliant IBC Listed (International Building Code)
 Code Compliant IRC Listed (International Residential Code)
 Code Compliant FBC Listed (Florida Building Code)
 Code Compliant FRC Listed (Florida Residential Code)
 Code Compliant COLA Listed (City of Los Angeles)
 Tested in accordance with AC308 and AC58 for use in structural concrete and masonry



INSTALLATION INSTRUCTIONS:

Drilling

Precaution: Wear suitable eye and skin protection. Avoid inhalation of dust during drilling and/or removal.

1. Drill a hole into the base material with an electric or battery-operated hammer drill to the size and embedment required by the selected steel hardware element. The tolerances of the carbide drill bit must meet the requirements of ANSI Standard B212.15.

2. Starting from the bottom or back of the anchor hole, blow the hole clean with either compressed air (min. 6 bar / 90 psi) a minimum of two times, until return air stream is free of noticeable dust. If the back of the drilled hole is not reached an extension shall be used or with a blowout bulb or canister.

2b. Determine brush diameter for the drilled hole. Brush the hole with the selected wire brush a minimum of two times (2×). A brush extension (supplied by Aerosmith Fastening) must be used for drill hole depth > 6" (150 mm). The brush should resist insertion into the drilled hole - if not the brush is too small and must be replaced with the proper brush diameter. If the back of the drilled hole is not reached a brush extension shall be used.

2c. Finally blow the hole clean again with compressed air (min. 6 bar / 90 psi) or blow out bulb or cannister a minimum of two times, until return air stream is free of noticeable dust. If the back of the drilled hole is not reached an extension shall be used. When finished the hole should be clean and free of dust, debris, ice, grease, oil or other foreign material.

3. Check adhesive expiration date on cartridge label. Do not use Expired Product. Review Safety Data Sheet (SDS) before use. For the permitted range of the base material and cartridge temperature see ESR-5901 or cartridge label. Attach a supplied mixing nozzle to the cartridge. Do not modify the mixer in any way and make sure the mixing element is inside the nozzle. Load the cartridge into the correct dispensing tool.

Note: Always use a new mixing nozzle with new cartridges of adhesive and also for all work interruptions exceeding the published gel (working) time of the adhesive.

4. Prior to inserting the anchor rod or rebar into the filled drilled hole, the position of the embedment depth has to be marked on the anchor. Verify anchor element is straight and free of surface damage.

5. Adhesive must be properly mixed to achieve published properties. Prior to dispensing adhesive into the drilled hole, separately dispense at least three full strokes of adhesive through the mixing nozzle until the adhesive is a consistent gray color. Review and note the published working and cure times in ESR 5901 or on cartridge label. prior to injection of the mixed adhesive into the cleaned anchor hole.

6. Fill the cleaned hole approximately two-thirds full of mixed adhesive starting from the bottom or back of the anchor hole. Slowly withdraw the mixing nozzle as the hole fills to avoid creating air pockets or voids. If the bottom or back of the anchor hole is not reached with the mixing nozzle only an extension tube supplied by Aerosmith Fastening must be used with the mixing nozzle.

In case of using the extension tube VL16/1,8 (Cat# 16004), cut the tip of the mixer nozzle at position "X". Piston plugs must be used with and attached to mixing nozzle and extension tube for:

- overhead installations and installations between horizontal and overhead
- all installations with drill hole depth $d_0 > 10"$ (250 mm)
- all installations in submerged bore holes with anchor rod 5/8" to 1-1/4" (M16 to M30) diameter and rebar sizes #5 to #11 ($\varnothing 14$ to $\varnothing 36$)

Insert piston plug to the back of the drilled hole and inject as described in the method above. During installation the piston plug will be naturally extruded from the drilled hole by the adhesive pressure.

Attention! Do not install anchors overhead or upwardly inclined without installation hardware supplied by Aerosmith Fastening and also receiving proper training and/or certification. Contact Aerosmith Fastening for details prior to use.

7. The anchor should be free of dirt, grease, oil or other foreign material. Push clean threaded rod or reinforcing bar into the anchor hole while turning slightly to ensure positive distribution of the adhesive until the embedment depth is reached. Observe the gel (working) time.

8. Be sure that the anchor is fully seated at the bottom of the hole and that some adhesive has flowed from the hole and all around the top of the anchor. If there is not enough adhesive in the hole, the installation must be repeated. For overhead applications and applications between horizontal and overhead the anchor must be secured from moving/falling during the cure time (e.g. wedges). Minor adjustments to the anchor may be performed during the gel time but the anchor shall not be moved after placement and during cure.

9. Allow the adhesive anchor to cure to the specified full curing time prior to applying any load. Do not disturb, torque or load the anchor until it is fully cured.

10. After full curing the adhesive anchor, a fixture can be installed to the anchor and tightened up to the maximum torque by using a calibrated torque wrench. Take care not to exceed the maximum torque for the selected anchor.

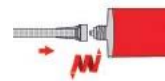
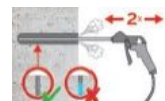
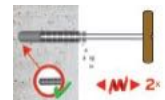
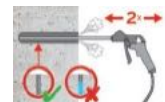
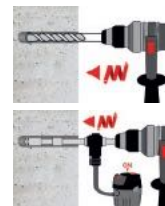

Sure-Set® ACR-10 and ACR-28 Plus+ Epoxy Acrylate

Aerosmith's Sure-Set® Epoxy Acrylate Plus+ adhesive anchors are specifically designed to resist static, wind or Seismic events. It is also ideally suited for high load and Heavy duty structural applications. It can be used with threaded rod, reinforcing bar, and steel dowels in solid base materials or in conjunction with an Aerosmith Stainless steel screen tube for hollow baseanchoring applications. Sure Set Plus + has not only been evaluated by ICC-ES it has been fire tested and approved to be used with potable water carrying the WQA's Gold Seal of approval.

Suitable for use in **CRACKED AND UNCRACKED CONCRETE, CATEGORY 1.**

DESCRIPTION:

ACR10/28 Plus+ is an easy dispensing, rapid-curing, high strength anchoring adhesive which is formulated for use by trained professionals. Please refer to installation instructions and MSDS for additional detailed information.



APPLICATIONS:

- Structural Applications in Cracked and Uncracked
- Concrete
- Pinning Building Facades
- Post installed rebar connections
- Crash Barriers
- The attachment of Structural steel to concrete
- Railings
- Signage
- Rebar Doweling
- Sill plate attachments: suitable for horizontal, vertical and overhead anchoring applications
- cable trays
- Lighting Stanchions
- Conveyors
- Racking

IMPORTANT INFORMATION:

- ICC-ES Evaluated ESR-5945
- Two Year Shelf Life when stored properly
- Certificated through WQA's Gold Seal program for drinking water system components
- For heavy anchoring and post-installed rebar connection
- Seismic rated
- Can be applied in dry, wet, submerged concrete or water filled bore holes
- High chemical resistance
- Low odor
- High bending and pressure strength
- Cartridge can be reused up to the end of the shelf life by either replacing the static mixer or resealing cartridge with the sealing cap

APPROVALS AND LISTING:

- ICC-ESR-5945 for use in Cracked and Uncracked Concrete category 1
- IBC Listed (International Building Code)
- IRC Listed (International Residential Code)
- FBC Listed (Florida Building Code)
- FRC Listed (Florida Residential Code)
- COLA Listed (City of Los Angeles)
- Tested in accordance with AC308 and AC58 for use in structural concrete and masonry

BASE MATERIALS:

- Concrete
- Solid & hollow masonry
- Hard natural stone
- Solid rock
- Voided stone or roc

(If using in hollow base material applications, a stainless steel or nylon screen tube is required to encapsulate the adhesive)



ESR-5945



Part ID	Product	Cartridge size	Carton Quantity
Sure-Set® ACR-10 Plus+	Sure-Set® ACR-10 Plus+	9.5 oz (280 ml)	12
Sure-Set® ACR-28 Plus+	Sure-Set® ACR-28 Plus+	27.9 oz (825 ml)	12

PRECAUTION:

Safety glasses and dust masks should be used when drilling holes into concrete, stone and masonry. Wear gloves and safety glasses when handling and dispensing adhesive. Do not sand the adhesive and create silica dust which could be inhaled. Avoid skin and eye contact. Use a NIOSH-approved chemical mask to avoid respiratory discomfort if working indoors or in a confined area, or if sensitive to adhesive odors. Wash hands or other affected body parts with soap and water if skin contact occurs. Flush eyes with plenty of water and seek immediate medical attention if eye contact occurs. Move to fresh air if adhesive odor begins to cause discomfort.

IMPORTANT!

Before using, read and review Material Safety Data Sheet (MSDS). This product contains crystalline silica and as supplied does not pose a dust hazard. IARC classifies crystalline silica (quartz sand) as a Group I carcinogen based upon evidence among workers in industries where there has been long-term and chronic exposure (via inhalation) to silica dust; e.g. mining, quarry, stone crushing, refractory brick and pottery workers. This product does not pose a dust hazard; therefore, this classification is not relevant. However, if reacted (fully cured) product is further processed (e.g. sanded, drilled) be sure to wear proper respiratory and eye protection to avoid health risk.

HANDLING AND STORAGE:

Store in a cool, dry, well-ventilated area at temperatures between 32°F (0°C) and 86°F (30°C). Keep away from excessive heat and flame. Keep partially used containers closed when not in use. Protect from damage. Store away from heat and light. Before use see expiration date on product label.

Do not use expired product. Partially used cartridges may be stored with hardened adhesive in the attached mixing nozzle.

Note: If the cartridge is reused, attach a new mixing nozzle and discard the initial quantity of the anchor adhesive as described in the setting instructions (steps #3 and #5).

INSTALLATION INSTRUCTIONS WHEN USED IN SOLID BASE MATERIALS

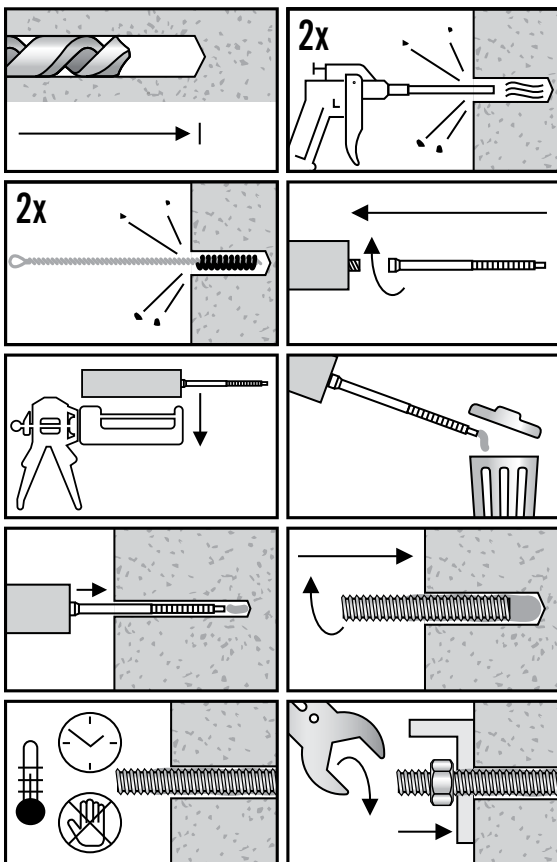

INSTALLATION INSTRUCTIONS WHEN USED IN OVERHEAD APPLICATIONS

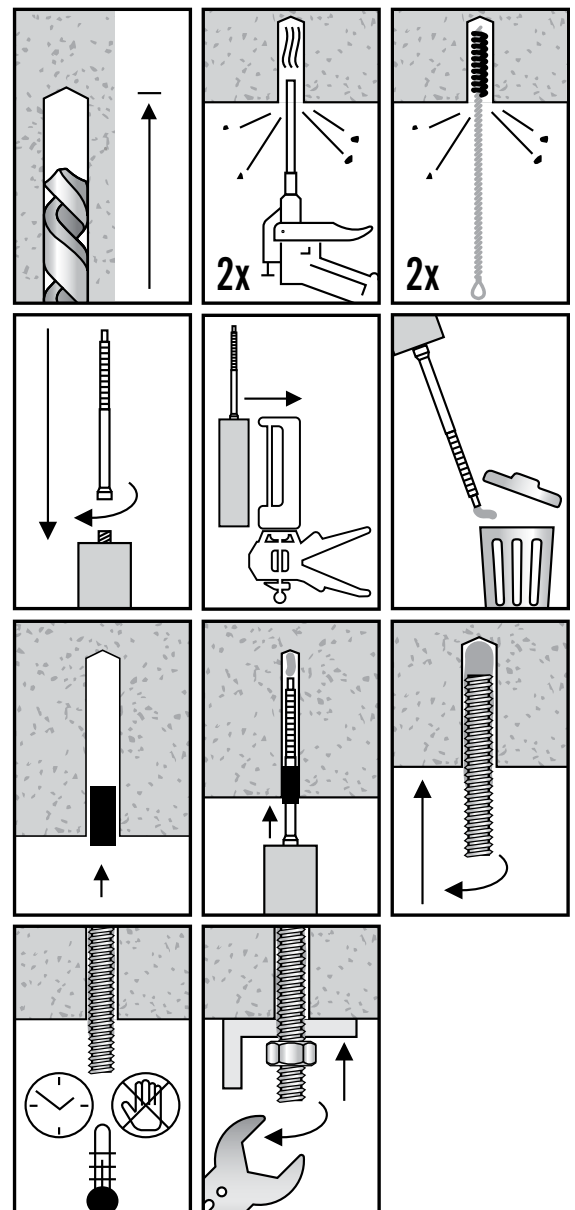

SURE-SET® PURE EPOXY ACCESSORIES

HOLE CLEANING BRUSHES



Part ID	Description	Box Quantity
716BRUSH	3/8 Brush - 7/16 Hole	1
916BRUSH	1/2 Brush - 9/16 Hole	1
1116BRUSH	5/8 Brush - 11/16 Hole	1
78BRUSH	3/4 Brush - 7/8 Hole	1
1BRUSH	7/8 Brush - 1 Hole	1
118BRUSH	1 Brush - 1 1/8 Hole	1
138BRUSH	1 1/4 Brush - 1 3/8 Hole	1
112BRUSH	1 3/8 Brush - 1 1/2 Hole	1

PURE EPOXY MIXING NOZZLES



Part ID	Description	Bag Quantity	Carton Quantity
MN1021	Mixing Nozzle for 10 and 21 ounce Pure Epoxy	5	25
MN1021L	Mixing Nozzle for 10 and 21 ounce Pure Epoxy (Deep Holes)	5	25

EXTENSION TUBES

Part ID	Description	Box Quantity	Carton Quantity
ET38	3/8 inch Extension Tubing	1	12
ET916	9/16 inch Extension Tubing	1	12

DISPENSING TOOLS



Part ID	Description	Box Quantity
DT10	Sure-Set Manual Dispensing Tool 10 oz	1
DT22	Sure-Set Manual Dispensing Tool 22 oz	1
DTHD10	Sure-Set Heavy Duty Dispensing Tool 10 oz	1
DTHD22	Sure-Set Heavy Duty Dispensing Tool 22 oz	1

SCREEN TUBES - STAINLESS STEEL



Part ID	Description	Box Quantity
386SCREEN	3/8 x 6 300 Stainless Steel Screen	25
3810SCREEN	3/8 x 10 300 Stainless Steel Screen	25
126SCREEN	1/2 x 6 300 Stainless Steel Screen	25
1210SCREEN	1/2 x 10 300 Stainless Steel Screen	25
586SCREEN	5/8 x 6 300 Stainless Steel Screen	10
346SCREEN	3/4 x 6 300 Stainless Steel Screen	20

EPOXY STOPPERS



Part ID	Description	Box Quantity	Carton Quantity
ES18	18MM Epoxy Stoppers overhead	10	100
ES22	22MM Epoxy Stoppers overhead	10	100
ES30	30MM Epoxy Stoppers overhead	10	100

SURE-SET® EPOXY ACRYLATE (ACRYLIC) ACCESSORIES

HOLE CLEANING BRUSHES



Part ID	Description	Box Quantity
716BRUSH	3/8 Brush - 7/16 Hole	1
916BRUSH	1/2 Brush - 9/16 Hole	1
1116BRUSH	5/8 Brush - 11/16 Hole	1
78BRUSH	3/4 Brush - 7/8 Hole	1
1BRUSH	7/8 Brush - 1 Hole	1
118BRUSH	1 Brush - 1 1/8 Hole	1
138BRUSH	1 1/4 Brush - 1 3/8 Hole	1
112BRUSH	1 3/8 Brush - 1 1/2 Hole	1

ACRYLIC MIXING NOZZLES



Part ID	Description	Bag Quantity	Carton Quantity
MNA10	Mixing nozzle for 10 Ounce Acrylic Adhesive	5	25
MNA28	Mixing nozzle for 28 Ounce Acrylic Adhesive	5	25

EXTENSION TUBES

Part ID	Description	Box Quantity	Carton Quantity
ET38	3/8 inch Extension Tubing	1	12
ET916	9/16 inch Extension Tubing	1	12

DISPENSING TOOLS



Part ID	Description	Box Quantity
DT10	Sure-Set Manual Dispensing Tool 10 oz	1
DTHD10	Sure-Set Heavy Duty Dispensing Tool 10 oz	1
DT28	Sure-Set HD Manual Dispensing Tool 28 oz	1

SCREEN TUBES - STAINLESS STEEL



Part ID	Description	Box Quantity
386SCREEN	3/8 x 6 300 Stainless Steel Screen	25
3810SCREEN	3/8 x 10 300 Stainless Steel Screen	25
126SCREEN	1/2 x 6 300 Stainless Steel Screen	25
1210SCREEN	1/2 x 10 300 Stainless Steel Screen	25
586SCREEN	5/8 x 6 300 Stainless Steel Screen	10
346SCREEN	3/4 x 6 300 Stainless Steel Screen	20

EPOXY STOPPERS



Part ID	Description	Box Quantity	Carton Quantity
ES18	18MM Epoxy Stoppers overhead	10	100
ES22	22MM Epoxy Stoppers overhead	10	100
ES30	30MM Epoxy Stoppers overhead	10	100



aerosmith®

fastening systems



Why Sure-Set PE-10 and PE-21 Plus+?

Sure-Set® PE-10 and PE-21 Plus+ is a domestically made, two-part cartridge adhesive designed specifically for DOT, bridge and transportation infrastructure work—giving distributors a code compliant, in-demand solution to offer contractors working on federally funded projects.



Sure-Set® Plus+ meets the Buy America, Build America (BABA) requirements, allowing contractors to confidently use it on federally funded Transportation and Bridge projects.

ICC-ES listed for use in Cracked and Uncracked Concrete Category 1! The highest rating for reliability.

Great for a variety of DOT (Department of Transportation) projects that may require Bridge repairs, Guard rail installations, Signage, retrofits, concrete and rebar doweling, lighting stantions and more.



Manufactured in the USA
BABA:
Buy America,
Build America

Why Distributors are Stocking Sure-Set® PE-10 and PE-21 Plus+

Built specifically for Federally Funded Projects

New Formulation for easy dispensing

Available in:
10 Ounce cartridges
21 Ounce cartridges

Fits most competitors
Dispensing tools



Contact us for distributor pricing, product training materials, and technical documentation. Let us help you grow your adhesive business!

The New Sure-Bolt® With Atlantis Coating by Aerosmith®, cuts its own threads into Concrete and has an exterior Service life that exceeds 25 years!

Now with an ICC-ESR 4414 Listing for Cracked and Uncracked Concrete Category 1!

Atlantis coating is comprised of a multitude of coating protections.

First, a layer of Zinc and then 2 layers of epoxy coating!

Exceeds over 1000 hours of salt spray before any Red rust or corrosion appears

Great for most interior and exterior applications

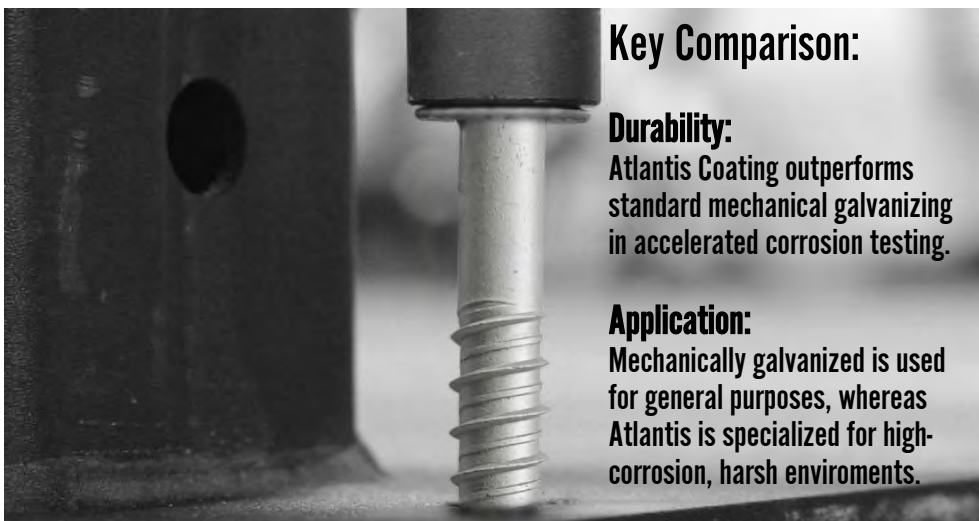

Key Comparison:

Durability:

Atlantis Coating outperforms standard mechanical galvanizing in accelerated corrosion testing.

Application:

Mechanically galvanized is used for general purposes, whereas Atlantis is specialized for high-corrosion, harsh environments.





Aerosmith® Headquarters and Direct Fastening Warehouse Locations:

5621 Dividend Road,
Indianapolis, Indiana 46241

Phone: Toll Free 1-800-528-8183

For general inquiries contact: questions@aerosmithfastening.com

For online orders contact: Customer_Service@aerosmithfastening.com

www.aerosmithfastening.com

Phone: Toll Free 1-844-373-2666

Mechanical and Adhesive Anchoring Warehouse Locations:

Aerosmith® Fastening Systems New Jersey

(Full Stocking Warehouse)
A&N Sales
70 Sewell Street
Glassboro, NJ 08028

Contact: Nick and Sam Casale

Phone: 610-461-2200

Fax: 610-461-2201

Email: Info@ansales.com

Aerosmith® Fastening Systems Indianapolis

(Full Stocking Warehouse)
MDC Marketing
3313 S. Arlington Ave #1
Indianapolis, Indiana 46203

Contact: Brian/Brenda and Michael Berry

Phone: 317-782-8001

Fax: 317-782-8002

Email: mdcmarketing@sbcglobal.net

Aerosmith® Fastening Systems Mid-Atlantic

(Full Stocking Warehouse)
Mainsource Corp.
9014 Junction Drive
Annapolis Junction, MD 20701

Contact: Brian Marks

Phone: 301-470-3060

Fax: 410-792-0953

Email: lbmarks@mainsourcecorp.com

Aerosmith® Fastening Systems Pittsburgh

(Ships from Glassboro, NJ)
Power Marketing and Sales
1360 Island Ave,
McKees Rock, PA 15136

Contact: Mark Schreiner and Bill Dugan

Phone: 412-771-3010

Fax: 412-771-9858

Email: Powermarketing1@verizon.net



aerosmith[®]

fastening systems

Aerosmith Direct Fastening
Toll Free 800-528-8183
questions@aerosmithfastening.com
5621 Dividend Road
Indianapolis, Indiana 46241
www.aerosmithfastening.com

Aerosmith Anchoring
(844)-373-2666
(844) DreamOn
Fax 914-817-0168



revised date 06/24/2026